

VARI***LITE**

VL800 EVENTPAR RGB

USER MANUAL

INTRODUCTION

OUR GOAL

We are committed to providing you the highest quality in customer service. Our comprehensive resources are available to help your business succeed and ensure you get the full benefit of being a Vari-Lite customer.

TECHNICAL SUPPORT

Our Service and Support team is tasked with online and field support, repair, demo, commissioning, maintenance contracts, and technical training for fixtures and systems. In addition, this team plays a large role in Systems sales, responsible for administering final commissioning, record-keeping, and organizing services. Refer to the back cover of this user manual for contacts in your region or visit WWW.VARI-LITE.COM/SUPPORT.

CUSTOMER SERVICE

Customer Service is responsible for boxed goods and spare parts quotations, order entry and fulfilment, project delivery, lead times, and general account management. They also manage all after sales warranty fulfilment, RGA, and repairs invoicing in tandem with our After Sales Service & Support team. Visit our website to find a customer service agent in your region.

ADDITIONAL DOCUMENTATION

Additional product documentation, including DMX maps, software, and photometric reports, is available for download on our website.

For more information on installing DMX512 control systems, the following publication is available for purchase from the United States Institute for Theatre Technology (USITT), "Recommended Practice for DMX512: A Guide for Users and Installers, 2nd edition" (ISBN: 9780955703522).

USITT Contact Information:

USITT

315 South Crouse Avenue, Suite 200

Syracuse, New York 13210-1844 USA

Phone: 800-938-7488 or +1-315-463-6463

Fax: 866-398-7488 or +1-315-463-6525

Website: www.usitt.org

ABOUT THIS DOCUMENT

Read all instructions before installing or using this product. Retain this user manual for future reference.

Additional product information and descriptions may be found on the product data sheet(s) which can be downloaded from the Vari-Lite website at WWW.VARI-LITE.COM.

This user manual provides necessary information regarding safety, installation, operation and routine maintenance for Vari-Lite VL800 EVENTPAR WW. Familiarizing yourself with this information will help you to get the most out of your product.

WARNING: It is important to read ALL accompanying safety and installation instructions to avoid damage to the product and potential injury to yourself or others.

This user manual covers the following model(s):

- VL800 EVENTPAR RGBA BLACK (912400575002), WHITE (912400576322), BRONZE (912400576326), AND ALUMINIUM (912400576324)

SAFETY WARNINGS AND NOTICES

Read this user manual in full before attempting to install, operate or maintain the fixture to which it relates. This user manual is intended to provide general guidance to such suitably qualified personnel. Installation and operation of the fixture are to be performed by qualified personnel only.

When using electrical equipment, basic safety precautions should always be followed including the following:

READ AND FOLLOW ALL SAFETY INSTRUCTIONS.

- Fixtures must be installed per the IP rating as marked on the unit. Failure to follow those markings may cause an unsafe condition and void warranty.
- Use safety tether when mounting.
- Equipment should be mounted in locations and at heights where it will not be readily subjected to tampering by unauthorized personnel.
- Not for residential use. Do not use this equipment for other than intended use.
- Note distance requirement(s) from combustible materials or illuminated objects. Do not mount near gas or electric heaters.
- Install only in locations with adequate ventilation. Ensure sure that ventilation slots are not blocked.
- Ensure that the voltage and frequency of the power supply match the power requirements of the fixture.
- The fixture must be earthed/grounded to the appropriate conductor.
- Do not operate fixture outside the specified ambient temperature range.
- Do not connect the fixture to any dimmer pack.
- The use of accessory equipment not recommended by the manufacturer may cause an unsafe condition and void warranty.
- Refer service to qualified personnel. This fixture contains no user serviceable parts.
- Prior to first use, carefully inspect fixture to ensure no damage has occurred during shipping.
- Materials used in the manufacturing process can cause strong odors when the product is new. These odors dissipate over time.
- Prior to each use, carefully inspect power cables and replace any damaged cables.
- Exterior surfaces of the luminaire will be hot during operation. Take appropriate precautions.
- Continuous use of the fixture may shorten the lifespan. Power down the fixture when not in use.
- Do not cycle power on and off repeatedly. Disconnect mains power if the fixture is not used for an extended period.
- Clean fixtures regularly, particularly when working in a dusty environment.
- Never touch power cables or wires while the fixture is powered on.
- Avoid entangling power wires with other cables.
- In the event of a serious operating problem, immediately discontinue using the fixture.
- It is hazardous to operate luminaires without lens or shield. Shields, lenses, or ultraviolet screens shall be changed if they have become visibly damaged to such an extent that their effectiveness is impaired, for example, by cracks or deep scratches.
- Original packing materials can be reused for transporting the fixture.
- Do not look directly at the LED light beam while the fixture is on.
- This is a Class A product. In a domestic environment this product may cause radio interference, in which case, the user may be required to take adequate measures.
- The light source contained in this luminaire shall only be replaced by the manufacturer or service agent or similarly qualified person.

SAVE THESE INSTRUCTIONS.

WARNING: Refer to National Electrical Code® and local codes for cable specifications. Failure to use proper cable can result in damage to equipment or danger to personnel. Caution Against Direct Sunlight Through Front Lens Assembly

CAUTION AGAINST DIRECT SUNLIGHT THROUGH FRONT LENS ASSEMBLY

The design and nature of the front lens assembly in Vari-Lite LLC luminaires is to efficiently focus the light energy from the luminaire's lamp for maximum light output.

- When the front lens assembly is exposed to direct sunlight or intense light from neighboring fixtures, the lens will collect and intensify this light and focus it back into the fixture. Intense sunlight or beams from other fixtures can cause damage to internal assemblies contained within the fixture.
- When fixture is not in use and direct sunlight or other intense light is present, position luminaires so their front lens assembly is not directly exposed to the light source.

CAUTION AGAINST POWERING LUMINAIRES FROM DIMMER CIRCUITS

It is not recommended to power any Vari-Lite LLC luminaire from a dimmer - even in 'NONDIM' mode. Dimmer and non-dim modules are not suitable sources of power because their output modifies the AC wave form. This may work for a short time, but eventually results in power problems, luminaire mis-operation and/or failure.

- When using a power distribution rack, do not use dimmer or non-dim modules to power any Vari-Lite LLC luminaire. Damage to the luminaire can occur.
- Using a dimmer or non-dim module to power your Vari-Lite LLC luminaire will void your luminaire's warranty.

CAUTION AGAINST THE USE OF THIRD PARTY PARTS OR ACCESSORIES

- Heat and heat distribution are important factors when operating Vari-Lite LLC luminaires. Vari-Lite LLC luminaires are designed to dissipate heat efficiently and safely. Any blockages or obstructions, such as aftermarket baffles, covers, enclosures, etc. can interrupt the luminaire's ability to dissipate heat properly and can damage the luminaire.
- Vari-Lite LLC cannot be responsible for issues arising from non-approved parts and accessories installed on or used with any Vari-Lite LLC product. Customers of such products should contact the manufacturer directly for assistance and support.

TRANSPORTING LUMINAIRES

When shipping or transporting luminaires, Vari-Lite LLC recommends that the luminaire(s) be sufficiently protected against any (including, but not limited to) shock, vibration, drops, jarring, exposure to the environment, etc.

Failure to sufficiently protect any Vari-Lite LLC luminaire during shipping or transportation will result in damage and void the luminaire's warranty. Vari-Lite LLC will not be responsible for any shipping damage or breakage of any product under any circumstances. Vari-Lite LLC will not be responsible for any third party case manufacturer's cases.

NOTE: As with all automated luminaires, proper handling and suitable protective shipping cases should be used when transporting fixtures to reduce the risk of damage.

TRANSPORTATION AND SHIPPING CASE REQUIREMENTS

Cases to transport Vari-Lite LLC luminaires should meet the following loading requirements:

- Luminaire head, yoke, and enclosure sub-assemblies shall be equally supported and constrained where no one sub-assembly (head, yoke, or enclosure) fully supports the entire mass of the luminaire.
- The interior of the case shall be of high quality and uniform density foam. The foam shall be of the same type and density throughout as to equally and uniformly support loading at every contact surface.
- The case shall, when laid on any of its six (6) surfaces, maintain the loading requirements outlined above.
- All cases not meeting the aforementioned loading requirements, with wheels, shall have markings on the exterior of the case that the unit is to be transported on its wheels only (e.g. "Case must be transported and remain [at all times] on its wheels").

COMPLIANCE NOTICE



FCC DECLARATION OF CONFORMITY

This equipment has been tested and found to comply with the limits for a Class A digital device pursuant to Part 15 of FCC Rules. These limits are designed to provide reasonable protection against harmful interference when this equipment is operated in a commercial environment. This equipment generates, uses, and can radiate radio frequency energy and, if not installed and used in accordance with Vari-Lite system, service, and safety guidelines, may cause harmful interference to radio communications.

As tested under this standard:

FCC 47CFR 15B cIA*CEI

Issued:2009/10/01 Title 47 CFR Part 15 Subpart B Unintentional Radiators Class A

Operation of this equipment in a residential area is likely to cause harmful interference, in which case the user will be required to correct the interference at his/her own expense.



EU DECLARATION OF CONFORMITY

We, Vari-Lite LLC., 10911 Petal Street, Dallas, Texas 75238, declare under our responsibility for the products contained herein are in conformity with the essential requirements of the following European Directives and harmonized standards:

Low Voltage Director (LVD), 2006/95/EC

EN 60589-2-17:1984+A1:1987+A2:1990 used in conjunction with 60598-1:2008/A11:2009

Electromagnetic Compatibility Directive (EMC), 2004//108/EC

EN 55022:2010, EN55024:2010

HOW TO OBTAIN WARRANTY SERVICE

A copy of the Limited Warranty card was included in the shipping package for this product.

To obtain warranty service, please contact customer service at 1-214-647-7880, or **entertainment.service@signify.com** and request a Return Material Authorization (RMA) for warranty service. You will need to provide the model and serial number of the item being returned, a description of the problem or failure and the name of the registered user or organization. If available, you should have your sales invoice to establish the date of sale as the beginning of the warranty period. Once you obtain the RMA, pack the unit in a secure shipping container or in its original packing box. Be sure to clearly indicate the RMA number on all packing lists, correspondence, and shipping labels. If available, please include a copy of your invoice (as proof of purchase) in the shipping container.

With the RMA number written legibly on or near the shipping address label, return the unit, freight prepaid, to:

Vari-Lite LLC
Attention: Warranty Service (RMA# _____)
10911 Petal Street
Dallas, Texas 75238
USA

As stated in the warranty, it is required that the shipment be insured and FOB our service center.

IMPORTANT! When returning products to Vari-Lite for repairs (warranty or out-of-warranty) from a country other than the USA, "Vari-Lite LLC", must appear in the address block as the Importer of Record (IOR) on all shipping documentation, Commercial Invoices, etc. This must be done in order to clear customs in a timely manner and prevent returns.

1 DESCRIPTION

FEATURES

- Cost-effective LED PAR built by Vari-Lite - LED PAR from a brand you trust.
 - Retro styling, color, and output - Looks, feels, and functions like a classic tungsten fixture, but with modern capabilities.
 - RGBA and WW versions - Get that perfect tungsten look with output and color that matches the original fixtures.
 - Gel color presets matched to traditional gel numbers - Use the colors you have always used without the need to change gels.
 - Outdoor rated (IP24) - Rated against water spray from any direction, providing weather protection.
 - Adjustable frequency to exceed camera frame rates - camera-friendly fixtures for IMAG or live televised events.
 - Multiple housing finishes available, including black, white, bronze, and polished aluminium - select the perfect look for any event.
- For detailed product information, please refer to the Product Guide at <https://www.vari-lite.com/global/products/vl800-eventpar-rgba>

Download the product datasheet(s) from the Vari-Lite website at WWW.VARI-LITE.COM for the full technical specifications.

2 INSTALLATION & SETUP

POWER AND DATA CABLING REQUIREMENTS

CONNECTING POWER

This fixture requires standard AC power distribution from 120-240VAC, 50/60 Hz. Current required depends on the AC supply voltage and product model

Depending on the application, the luminaire's AC input cable may require a different connector. If required, install a new connector meeting your requirements using the following wire color code reference:

WIRE*	CONNECTION
Green/yellow	AC ground
Blue	AC neutral
Brown	AC line

* International (Harmonized) Standard

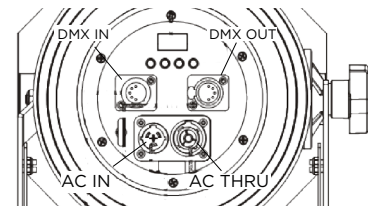

WARNING: DO NOT connect to three-phase service in countries with 240V power.

For single-phase power from 120-240 volts RMS:

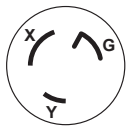

CONNECTION	PIN
AC neutral	X
AC line	Y
Ground (earth)	G

For three-phase power at 208 volts RMS:

CONNECTION	PIN
Phase 1	X
Phase 2	Y
Ground (earth)	G

CURRENT VERSUS VOLTAGE

TABLE 1 provides the luminaire's current draw at specific voltages. Total luminaire current is calculated with the lamp on and all motors sequencing.

WARNING! It is the responsibility of the user to adequately protect supply source with a correct size and type circuit breaker and not overload circuits.

WARNING! It is not recommended to power any Vari-Lite luminaire from a dimmer - even in 'NONDIM' mode. Dimmer and non-dim modules are not suitable sources of power because their output modifies the AC wave form. This may work for a short time, but will eventually result in power problems, luminaire mis-operation and/or failure and may void the luminaire's warranty.

TABLE 1. CURRENT VS. VOLTAGE (300W LED)

AC VOLTAGE AT 60HZ	TOTAL CURRENT
120V	3.09A
180V	2.06A
208V	1.78A
230V	1.61A
240V	1.55A

DATA CABLE - DMX512/RDM

The luminaire is equipped with two, 5-pin XLR connectors for DATA IN and DATA THRU (out) applications. DATA IN requires a 5-pin, female XLR connector and DATA THRU requires a 5-pin, male XLR connector. When purchasing or constructing data cable, it is important that not only the correct cable type be used, but also quality cable to ensure a reliable DMX512 system. All cable must be IP65 rated or higher. Your cabling should meet the following USITT DMX specification requirements:

- Suitable for use with EIA485 (RS485) operation at 250k baud
- **MUST BE IP65 RATED OR HIGHER - see below**
- Characteristic impedance 85-150 ohms, nominally 120 ohms
- Low capacitance
- Two twisted pairs
- Foil and braid shielded
- 24 AWG min. gauge for runs up to 1000 feet (300m)
- 22 AWG min. gauge for runs up to 1640 feet (500m)

NOTE: Microphone type cable and other general purpose, two-core audio or signal cable are not suitable for use with DMX512.

Refer to the USITT Recommended Practice for DMX512 guide for additional information regarding DMX512 systems.

The XLR 5-pin connectors should be wired as follows:

RECOMMENDED CABLE TYPES/MANUFACTURERS

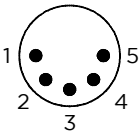
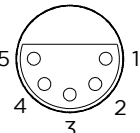
Pin/Wire Code to XLR Connectors						
Data Thru Cable Pinout	Pin 1	Pin 2	Pin 3	Pin 4	Pin 5	Data In Cable Pinout
	Foil & Braided Shield	1st conductor of 1st twisted pair	2nd conductor of 1st twisted pair	1st conductor of 2nd twisted pair	2nd conductor of 2nd twisted pair	
Male Conn.		Data (-)	Data (+)	Data (-)	Data (+)	Female Conn.

These are only a few of the suitable cable types. Any quality EIA485, twisted pair, 120 ohm, shielded cable will also work. Refer to [TABLE 2](#).

IP65 CONNECTORS

IP65 rated connectors can include, but are not limited to

- NEUTRIK TOP Series
- Seetronic W Series

NOTE: Check cable o-ring and rubber seals prior to use. If damaged or missing required lubricant then the cable should not be used.

TABLE 2. RECOMMENDED CABLES

TYPE	PAIRS	ZΩ*	JACKET	AWG	USE	TEMP (°F)	TEMP (°C)
BELDEN CABLES							
1215A	2	150	PVC	26	IBM Type 6 Office cable	75	24
1269A	2	100	PTFE	22 (solid)	High Temp, Plenum cable	200	93
8102	2	100	PVC	24	UL2919	80	27
8132	2	120	PVC	28	UL2919	80	27
8162	2	100	PVC	24	UL2493	60	16
82729	2	100	PTFE	24	High Temp, Plenum cable	200	93
88102	2	100	PTFE	24	High Temp, Plenum cable	200	93
89696	2	100	PTFE	22	High Temp, Plenum cable	200	93
89729	2	100	PTFE	24	High Temp, Plenum cable	200	93
89855	2	100	PTFE	22	High Temp, Plenum cable	200	93
9729	2	100	PVC	24	UL2493	60	16
9804	2	100	PVC	28	UL2960	60	16
9829	2	100	PVC	24	UL2919	80	27
9842	2	120	PVC	24	UL2919	80	27
PROPEX CABLES							
PC224P	2	110	Polyurethane	22	Heavy Duty and Portable	105	41
PC224T	2	110	PVC	22	UL2464	105	41
PC226T	3	110	PVC	22	UL2464		

* Characteristic impedance

TERMINATION CONNECTOR

A XLR termination connector is required at the last luminaire (or “far end of the line”) to prevent signal reflections. Signal reflections may cancel out the signal at certain line lengths, resulting in errors. The terminator is also necessary for software downloads and running tests on multiple luminaires. To construct your own connector, you will need the following components:

- 5-pin, male XLR connector.
- Two 1/4W 5% 120 ohm resistors.

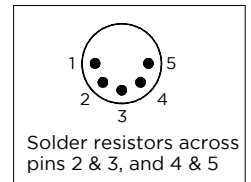

NOTE: A male termination connector is available as an accessory from Vari-Lite.

HANGING THE FIXTURE

The VL800 EVENTPAR WW can be hung horizontally or vertically from any structure designed to work with the type of load created by this luminaire. One mounting truss hook or other mounting hardware is required. Many compatible truss hooks are available from different manufacturers for your particular needs.

Install mounting hook:

Step 1. Install truss hook (also refer to “Truss Hook Hardware (by others)” below) for additional information) on yoke as shown in Figure at right..

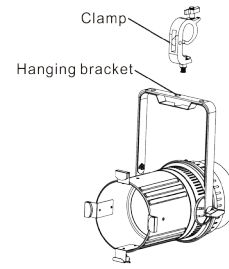

NOTE: Various types of truss hooks can be used. The hook (as shown in the example above) as well as many other standard hooks, can be ordered separately.

TRUSS HOOK HARDWARE (BY OTHERS)

When installing hanging hooks, Vari-Lite strongly recommends the use of a Belleville washer when installing a truss hook or claw. The Belleville washer's size should be approximately 13-25mm (0.5-1.0 in) diameter. Belleville washers are available in various thicknesses and any of the following thicknesses are acceptable for the application described: 0.9mm, 1.0mm, 1.3mm, 1.9mm (0.035-inch, 0.043-inch, 0.050-inch, 0.073-inch).



The washer serves two purposes:

- **To spread out the load.** When a washer IS NOT used, the bolt head (without a washer) concentrates the load in a smaller area, creating focused stress on the steel bracket, making premature failure possible. A steel washer is recommended to spread this load over a larger surface area.
- **To keep the bolt in place.** The recommended Belleville washer maintains tension in the bolted assembly and prevents it from vibrating loose.

If a Belleville washer is not available, a regular flat washer measuring in diameter of 25mm (1 inch) minimum can be used in conjunction with a suitable split lock washer situated between the bolt head and flat washer.

Installing in Truss:

- Step 1. Lift luminaire into mounting position.
- Step 2. Secure in place with truss hook. Ensure truss hook hardware that locks hook in place (e.g. wing bolt) is properly tightened and that luminaire is fully supported.
- Step 3. Attach safety cable (as required) as follows:
 - a. Loop safety cable at least once around safety cable anchor point rod.
 - b. Loop safety cable at least once around truss/pipe and secure around pipe.
- Step 4. Connect power and data cables.

FLOOR MOUNTING

All luminaires included in this manual are designed to sit directly on its yoke in a floor installation application. Simply spread the yoke floor support and place on flat, stable surface.

CONNECTING DATA AND POWER

A maximum of 32 luminaires may be connected in any one DMX data link.

NOTE: This maximum limit applies to the luminaire “daisy chain” only. Your system or console may require fewer luminaires on a single data link path. Consult your console documentation for more information.

To connect power and data:

- Step 1. Connect data cable from console to first luminaire in chain at DATA IN connector.
- Step 2. If required, connect additional data cables from DATA THRU connectors to DATA IN connectors of remaining luminaires in link.
- Step 3. At last luminaire in link, install male termination connector at DATA THRU connector. (Luminaires and other devices on the same DMX chain may not function properly without termination.)
- Step 4. Connect AC Input Cable connector to power input source.
- Step 5. Dress AC input and data cables and secure them so that they will not interfere with luminaire head and yoke movement.

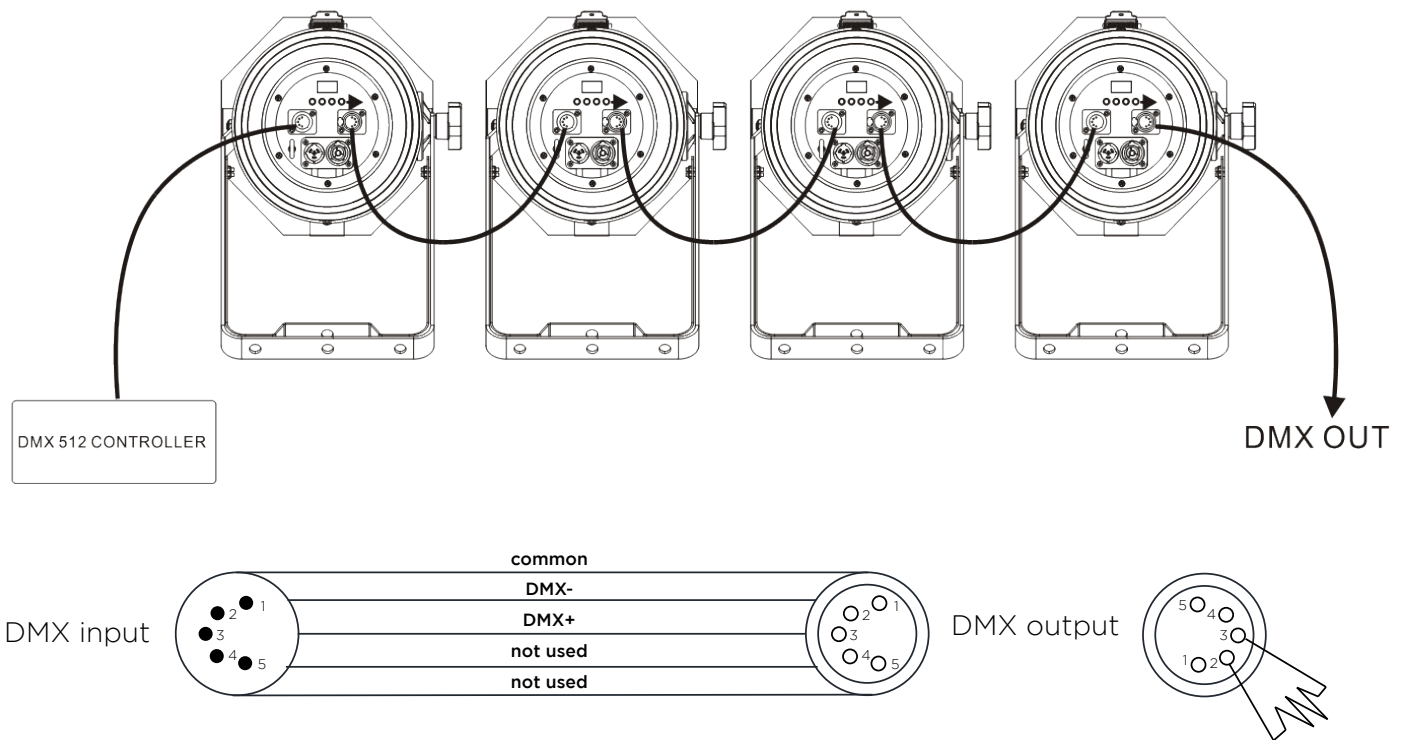

POWERING UP

POWER-UP PROCEDURE

When AC power is applied, the luminaire immediately boots and performs a systems check. If any errors are found, they will be reported on the display.

To power up:

- Step 1. At each luminaire, apply power connecting the power cable to the unit.
- Step 2. Luminaire boots and performs a systems check.

ADDRESSING

PROGRAM STARTING ADDRESS

The address setting for DMX console controlled systems is entered using the Menu Display. The luminaire retains the DMX address even if power is removed.

DMX ADDRESS

To set, edit, and save a DMX address:

- Step 1. Press [MENU].
- Step 2. Press [UP] / [DOWN] arrows until Address appears. Press [ENTER].
- Step 3. Use [UP] and [DOWN] arrow buttons to scroll through all available starting address.
- Step 4. Once correct starting address is selected, press [ENTER] to set..

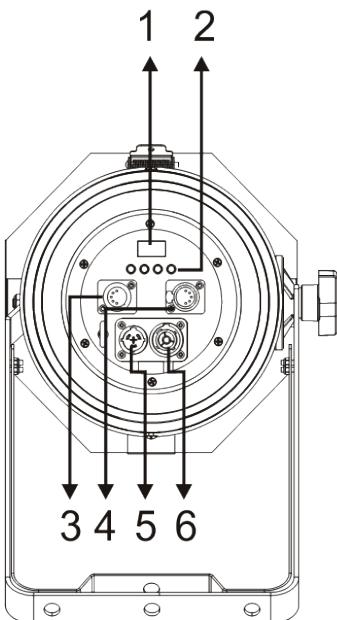

CONTROL PANEL

1 Display. Shows menu and selected functions

2 Buttons.

- MENU To select the programming functions
- UP To go backward in the selected functions
- DOWN To go forward in the selected functions
- ENTER To confirm the selected functions

3 DMX/RDM input. Connectors for DMX 512 operation, 5-pin XLR cable to link the DMX console

4 DMX/RDM thru. Connectors for DMX 512 operation, 5-pin XLR cable to link the next unit

5 Power Input. Connects to supply power.

6 Power Thru. Connects to the next fixture.

TRANSPORTING

When shipping or transporting luminaires, Vari-Lite recommends that the luminaire(s) be sufficiently protected against any (including, but not limited to) shock, vibration, drops, jarring, exposure to the environment, etc. Failure to sufficiently protect any Vari-Lite luminaire during shipping or transportation will result in damage and void the luminaire's warranty. Vari-Lite will not be responsible for any shipping damage or breakage of any product under any circumstances. Vari-Lite will not be responsible for any third-party case manufacturer's cases.

NOTE: As with all automated luminaires, proper handling and suitable protective shipping cases should be used when transporting fixtures to reduce the risk of damage. For more information, please refer to Vari-Lite technical notice (TN-235) "Transportation and Shipping Case Requirements" in the "Support" area of the Vari-Lite web site.

TRANSPORTATION AND SHIPPING CASE REQUIREMENTS

Cases to transport Vari-Lite luminaires should meet the following loading requirements:

- Luminaire head, yoke, and enclosure sub-assemblies shall be equally supported and constrained where no one sub-assembly (head, yoke, or enclosure) fully supports the entire mass of the luminaire.
- The interior of the case shall be of high quality and uniform density foam. The foam shall be of the same type and density throughout as to equally and uniformly support loading at every contact surface.
- The case shall, when laid on any of its six (6) surfaces, maintain the loading requirements outlined above.
- All cases not meeting the aforementioned loading requirements, with wheels, shall have markings on the exterior of the case that the unit is to be transported on its wheels only (e.g. "Case must be transported and remain [at all times] on its wheels").

3 OPERATION

DMX OPERATION

DMX MAPS

The tables assume a DMX start address of 1. When a different starting address is used, this address becomes channel 1 function and other functions follow in sequence.

DMX CHANNEL			PARAMETER	DEFAULTS	RANGE DMX	DESCRIPTION
16-BIT & 16-BIT DECAY	8-BIT	COLOR MODE				
1	1		Intensity High	0	0-65535 (16bit) 0 - 255	Control of Dimming
2			Intensity Low			Fine Control of Dimming (16-BIT Only)
3	2	1	Red High	0	0-65535 (16bit) 0 - 255	Control of RED color
4			Red Low			Fine Control of RED color (16-BIT Only)
5	3	2	Green High	0	0-65535 (16bit) 0 - 255	Control of GREEN color
6			Green Low			Fine Control of Green color (16-BIT Only)
7	4	3	Blue High	0	0-65535 (16bit) 0 - 255	Control of BLUE color
8			Blue Low			Fine Control of BLUE color (16-BIT Only)
9	5	4	Amber High	0	0-65535 (16bit) 0 - 255	Control of AMBER color
10			Amber Low			Fine Control of AMBER color (16-BIT Only)

DMX CHANNEL			PARAMETER	DEFAULTS	RANGE DMX	DESCRIPTION
16-BIT & 16-BIT DECAY	8-BIT	COLOR MODE				
11	6		Color Preset	0	0 - 255 0 - 68 69 - 70 71 - 72 73 - 74 75 - 76 77 - 78 79 - 80 81 - 82 83 - 84 85 - 86 87 - 88 89 - 90 91 - 92 93 - 94 95 - 96 97 - 98 99 - 100 101 - 102 103 - 104 105 - 106 107 - 108 109 - 110 111 - 112 113 - 114 115 - 116 117 - 118 119 - 120 121 - 122 123 - 124	Access to preset colors Channel OFF (RGBA enabled) 0 - Color OFF 1 - White 10000K 2 - White 8000K 3 - White 6500K 4 - White 5600K 5 - White 5000K 6 - White 4500K 7 - White 4000K 8 - White 3200K 9 - White 3000K 10 - White 2700K 11 - Moroccan Pink 12 - Pink 13 - Flesh Pink 14 - Bright Rose 15 - Follies Pink 16 - Fuchsia Pink 17 - Surprise Pink 18 - Congo Blue 19 - Blue 20 - Virgin Blue 21 - Midnight Maya 22 - Double C.T. Blue 23 - Slate Blue 24 - Regal Blue 25 - Full C.T. Blue 26 - Steel Blue 27 - Lighter Blue

DMX CHANNEL			PARAMETER	DEFAULTS	RANGE DMX	DESCRIPTION
16-BIT & 16-BIT DECAY	8-BIT	COLOR MODE				
11	6		Color Presets	0	125 - 126	28 - Cyan
					127 - 128	29 - Marine Blue
					129 - 130	30 - Soft Green
					131 - 132	31 - Moss Green
					133 - 134	32 - Green
					135 - 136	33 - Fern Green
					137 - 138	34 - JAS Green
					139 - 140	35 - Pale Green
					141 - 142	36 - Spring Yellow
					143 - 144	37 - Yellow
					145 - 146	38 - Deep Amber
					147 - 148	39 - Chrome Orange
					149 - 150	40 - Orange
					151 - 152	41 - Magenta
					153 - 154	42 - Flame Red
					155 - 156	43 - Purple
					157 - 187	Spin CW Fast --> Slow
188 - 208	Spin CCW Fast --> Slow					
209 - 229	Random Color Fast --> Slow					
230 - 255	Channel Off					
12	7		Strobe Speed	0	0 - 255	.5hz to 30hz
13	8		Strobe Control	0	0 - 255	
					0 - 5	Open
					6 - 10	Closed
					11 - 15	Normal Strobe
					16 - 20	Random Strobe
					21 - 25	Random Sync Strobe
					26 - 255	Reserved

MENU FUNCTIONS

To access the menu, touch the MENU button. Then use the ARROW buttons to navigate through the menu items in the list. Touch ENTER to select. Repeat as needed to move through the menu lists. Once you have reached your desired selection, use the ARROW buttons to choose or set desired setting and then touch ENTER to store. Touching the MENU button will return to the previous menu level.

The VL800 EVENTPAR RGBA Display and Menu System provides local control for accessing the following fixture's settings:

- Address – to set the DMX address
- Configure – various parameter settings, set luminaire ID
- DMX – change the map, view incoming DMX, invert pan/tilt
- Fixture – fixture status, recalibrate, reboot, software version, view fixtures hours, service, etc.
- Test - test functions of parameters
- Manual Preset – edit and set the manual presets within the fixture

The menu system is controlled at the Menu Display available at the enclosure input panel. If there are multiple luminaires in a system, any settings or changes would need to be made at each Menu as desired

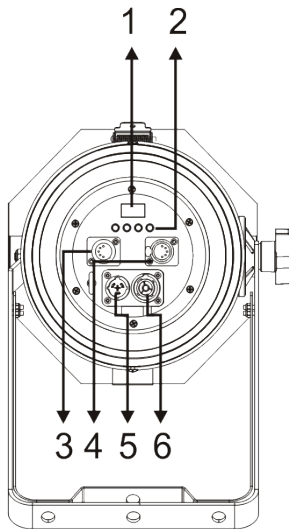

CONTROL PANEL

1 Display. Shows menu and selected functions

2 Buttons.

- MENU To select the programming functions
- UP To go backward in the selected functions
- DOWN To go forward in the selected functions
- ENTER To confirm the selected functions

3 DMX/RDM input. Connectors for DMX 512 operation, 5-pin XLR cable to link the DMX console

4 DMX/RDM thru. Connectors for DMX 512 operation, 5-pin XLR cable to link the next unit

5 Power Input. Connects to supply power.

6 Power Thru. Connects to the next fixture.

NOTE: Menu functions are subject to activation in subsequent software releases. Please check software release notes for details

TABLE 1. MENU FUNCTIONS							
LEVEL 1	LEVEL 2	LEVEL 3	LEVEL 4	LEVEL 5	LEVEL 6	DEFAULT	
Address	000-512					(Default 001)	
Configure	LED	LED Hours	XXXXXX h				
		Color Calibraiton	On Off			(Default)	
		Dimming Curve	Square Law Curve S Law Curve Linear Law Curve			(Default)	
		Dim Snap	Dim Snap Off Dim Snap On			(Default)	
		White Balance	Red		125 - 255		255
			Green		125 - 255		255
			Blue		125 - 255		255
			Amber		125 - 255		255
			Reset to default		Are You Sure?		
		Output Mode	Standard Studio Whisper			(Default)	
	Fan Mode	On Auto			(Default)		
	Dimming Speed	Fast Slow			(Default)		
	Refresh Rate	900Hz 910Hz 920Hz 930Hz 940Hz 950Hz 960Hz 980Hz 990Hz 1000Hz 1500Hz 2500Hz 4000Hz			(Default)		
Display	Orientation	Up Down			(Default)		
	On time	30 sec 5 min 10 min On			(Default)		
Reset Defaults	Are you sure?						

TABLE 1. MENU FUNCTIONS							
LEVEL 1	LEVEL 2	LEVEL 3	LEVEL 4	LEVEL 5	LEVEL 6	DEFAULT	
DMX	Data	Ch 1 - Intensity XXX (Value) Ch 2 - Intensity Fine XXX (Value) ...All functions					
	DMX Mode	16-bit 8-bit Color Mode 16-bit Decay				(Default)	
	DMX Fail	DMX Hold Black out				(Default)	
Fixture	Status	(No Errors... or displays a list of errors)					
	ReCal Fixture	Are you Sure?					
	Reboot Fixture	Are you sure?					
	Version	MM/DD/YY					
	Fixture Hours	XXXXXX h					
	Crossload (software)	Send					
	Service	Diagnostics	Fan Check LED Temp				
Test	All Test	(Run 'All Test')					
Manual Preset	Playback	Power Up Pre-set	01 - 20			(Default 0)	
		Preset Intensity	000 - 255			255	
		Priority	Preset DMX			(Default)	
		Power Up?	Preset Off Preset On			(Default)	
	Edit	Load Preset	01 - 20				
		Edit Settings	Intensity	0 - 255			
			Strobe	0 - 255			
			Color Preset	1 - 43			
			Red	0 - 255			
			Green	0 - 255			
			Blue Amber	0 - 255 0 - 255			
	Store	01 - 20	Are You Sure?	Yes No			
	Clear	01 - 20	Are You Sure?	Yes No			
Clear All Presets	Are You Sure?		Yes				

MENU SYSTEM

DISPLAY AND MENU SYSTEM OPERATION

The Display Menu system consists of several categories. Use the Menu Button to access the menu. Then use the Up/Down arrow to navigate. When you reach the desired item, touch the Enter But-

ton. To go backwards, touch the Menu Button.

To navigate and access menu settings/selections:

- Step 1. Make sure unit is powered and turned on.
- Step 2. Touch [MENU] to access menu categories.
- Step 3. Use two Arrow (▲ ▼) buttons to navigate through the various options and settings.
- Step 4. Once menu item is reached, touch [ENTER] to access the menu item parameters.
- Step 5. Make changes to parameters as desired.
- Step 6. Press [ENTER] button to accept changes.

ADDRESS

ADDRESS

Sets the starting DMX address for the fixture. Can also be set via RDM.

CONFIGURE

LED

This menu allows for viewing the LED engine hours, setting the dimming curve, dim snap, output mode, fan mode, and refresh rate.

LED Engine Hours

Displays the current LED engine hours.

Color Calibration

Turn the LED color calibration on or off. Can also be set via the control channel.

Dimming Curve

Select from Linear, S-Curve and Square Law. Can also be set via the control channel.

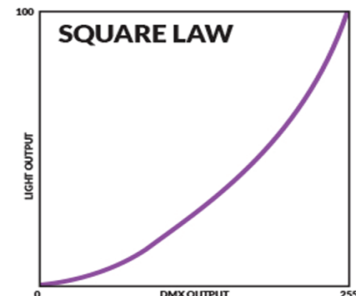
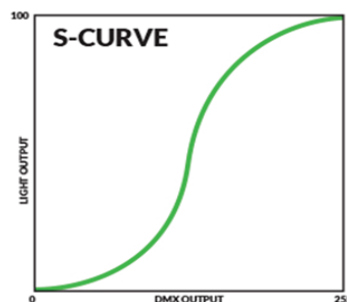
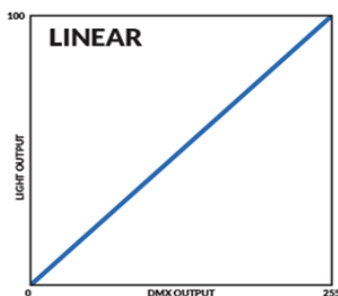

Dim Snap

Dim Snap On allows for fastest output changes between levels but reduces smoothness dimming the LED engine. Dim Snap Off ensures all fades between output levels remains smooth and flicker free but limits fast, instant snaps between levels. Can also be set via the control channel.

White Balance

White Balance allows for adjustment of the maximum output for RED, GREEN, BLUE, and AMBER in order to balance a group of fixtures to one another. The adjust for each individual level is 125 to 255. Meaning if RED is set to 125, a DMX value of 255 would set the RED to a lower than normal level. The defaults for all are 255.

Output Mode

Standard mode provides full LED output. Studio mode reduces fan speed to reduce the fan noise of the fixture. Whisper mode decrease the fan noise further. In both Studio mode and Whisper mode, the LED output will decrease accordingly. Can also be set via the control channel.

Fan Mode

Fan On runs fans at continuous max speed based on Output Mode. Fan Auto will reduce/increase speed on demand based on LED operating temperature. The fan will not exceed the maximum permissible level based on Output Mode. Can also be set via the control channel. See Appendix B.

Refresh Rate

Choose the refresh rate of the LED engine (see Display Menu Tree for list).

DISPLAY

Orientation

Sets the orientation of the display. Up should be chosen if the fixture is sitting on its base. Down should be chosen if the fixture is hanging.

On Time

Sets how long the display remains illuminated after the last button touch. Choose from 30 seconds, 5 minutes, 10 minutes, or always on.

RESET DEFAULTS

Resets all the factory defaults of the fixture. This includes setting the DMX Address to 001.

DMX

ADDRESS

Sets the starting DMX address of the fixture. Can also be set via RDM.

DATA

Allows the current DMX value present on each of the luminaire's DMX channels to be viewed.

DMX MODE

16-Bit

16-Bit Dimming and color control. See DMX map.

8-Bit

8-Bit Dimming and color control. See DMX map.

Color Mode

8-Bit color control only . See DMX map.

16-Bit Decay

16-Bit Dimming and color control. With Dim Snap Off, has a longer rise and decay time for Dimming and Color. See DMX map.

DMX FAIL

Allows a choice of Blackout or HOLD last DMX in the event the DMX signal is lost.

FIXTURE

STATUS

Shows list of error message from previous calibration. If none, it will say No Errors.

RECAL

Runs the calibration routine within the fixture. Can be performed via the control channel or RDM.

REBOOT FIXTURE

Restarts the entire operating system of the fixture. Can be performed via the control channel or RDM.

VERSION

Shows the current software version of the fixture. Version is listed in MM/DD/YY format. Can be viewed via RDM.

FIXTURE HOURS

Shows the accumulated hours the fixture has been powered on. Can be viewed via RDM.

CROSSLOAD (SOFTWARE)

Allows the current version of software installed in the fixture to be sent to other units via an attached DMX cable.

SERVICE

Fan Check

Displays all fan speeds in RPM.

LED Temp

Displays the current and maximum temperature (since the last power cycle) of the LED engine in °C.

TEST

ALL TEST

Runs the self-test of all functions. To stop the test, press [MENU].

MANUAL PRESET

PLAYBACK

Power Up Preset

Selects the preset (1 to 20) that will be played back after power up if enabled.

Preset Intensity

Selects the master intensity of a preset being played back (0 to 255).

Priority

Choose Preset if you always want a preset to playback. Choose DMX if you only want a preset to playback if there is no DMX present.

Power Up?

Choose Preset On if you want the fixture to playback the preset at power up. Choose Preset Off if you do not want a preset to play.

EDIT

Load Preset

Select from preset 1 to 20 and touch [ENTER]. That preset will be played back.

Edit Settings

Choose the function from the list you wish to edit and touch [ENTER]. Use the [UP]/[DOWN] buttons to set desired value. Touch [ENTER] to store.

Store

After setting all your functions, select which preset number you wish to store (1 to 20) and touch [ENTER]. Touch [ENTER] again to confirm when prompted.

Clear

Select the preset (1 to 20) you wish to clear and touch [ENTER]. Touch [ENTER] again to confirm when prompted.

Clear All Presets

When prompted, touch [ENTER] to confirm and all presets (1 to 20) will be erased.

WARNING: Clearing the presets CANNOT be undone!

APPENDIX A

CARE AND MAINTENANCE

TROUBLESHOOTING

The following are a few common problems that may occur during operation.

The unit does not work; light and fan do not turn on

- Check the connection of power and main fuse.
- Measure the mains voltage on the main connector.

Not responding to DMX controller

- Check DMX connectors, cables to see if they link properly.
- Check the address settings and DMX polarity.
- If you have intermittent DMX signal problems, check the pins on connectors or on DMX PCB of the unit or the previous one.
- Try to use another DMX controller.
- Check if the DMX cables run near or run alongside to high voltage cables that may cause damage or interference to DMX interface circuit.

CLEANING

The cleaning of internal lenses must be carried out periodically to optimize light output. Cleaning frequency depends on the environment in which the fixture operates damp, smoky or particularly dirty surrounding can cause greater accumulation of dirt on the fixture's optics.

General cleaning guidelines:

- Clean with soft cloth using normal glass cleaning fluid.
- Always dry the parts carefully.
- Clean the external optics at least every 30 days.

CLEANING OPTICS, FILTERS AND GOBOS

WARNING: Remove power from luminaires before performing maintenance.

WARNING: Acetone is a harsh cleaning agent and solvent. Acetone is very flammable.

Handle acetone according to manufacturer's safety instructions and precautions.

The front lens, optics/color filters may require cleaning after extended use.

- FRONT LENS: Use a isopropyl alcohol with a soft, lint-free cloth to clean the front lens.
- OPTICS/COLOR FILTERS/ GOBOS: Use Acetone or Isopropyl Alcohol along with a soft, lint-free cloth to clean the optics/color filters.

CAUTION: Do not continuously rub color filters or reflector - it may damage or remove the optical coating.

APPENDIX B FAN SPEED AND CONTROL

ADDENDUM

FAN SPEED AND CONTROL

All Vari-Lite luminaires will be governed by the same fan speed vs. noise levels vs. maximum power output rules as detailed below. The noise related to these levels will conform to the Noise Criteria levels, details of which are contained within this document.

There are three control parameters that can be selected separately or in conjunction (when permitted) to manage fan speed vs. noise levels vs. maximum power output.

NOTE: Not all fixtures have all modes or functions. Refer to DMX map and User Interface menu tree to see if your product has one or more of these functions.

Output Modes

These modes are selectable at the fixture's DMX control channel or via the fixture's user interface screen.

Boost mode - LED output boosted to >100% of standard output. Fan speeds increased to manage heat level of LED (may be limited to only run for XX hours). Fixture will not exceed NC45-NC55 sound levels in this mode.

Standard mode - Full LED output. Fan speed is set to cool LED appropriately but not exceed NC40 sound level in this mode.

Studio mode - Fan speed reduced to achieve 10% dB reduction from Standard mode and not exceed NC35 sound level. LED output is approximately 80% of Standard output to ensure LEDs operate at optimum temperature and output efficiency. Fan speed remains constant and does not ramp up or down.

Whisper mode - Fan speed reduced to achieve 30% dB reduction from Standard mode and not exceed NC25 sound level. LED output is approximately 60% of Standard output to ensure LEDs operate at optimum temperature and output efficiency. Fan speed remains constant and does not ramp up or down.

Silent mode - fans are turned off or turn very slowly to not contribute to fixture noise. LED output is capped to ensure LEDs operate at optimum temperature and output efficiency. Fans are either off or fan speed remains constant. Target NC15 sound level in this mode.

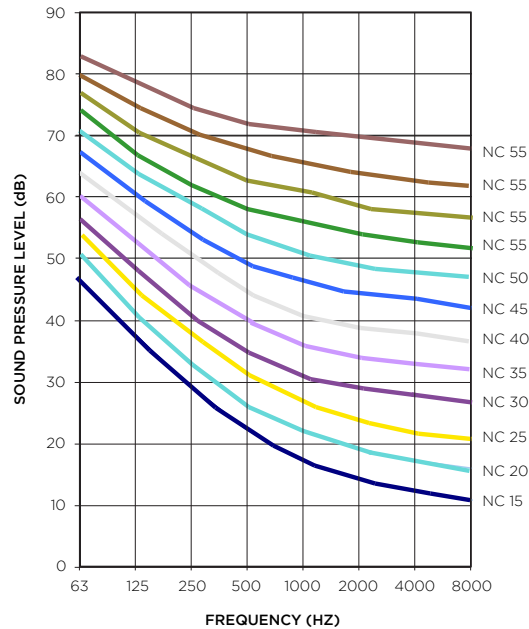

MODE	LED OUTPUT	FAN SPEED	NOISE CRITERION	EQUIVALENT SOUND LEVEL DBA (@3M)
Boost Mode	>100%	Boosted fan speed constant	NC45	50
Standard Mode	Full 100%	Full 100% constant	NC40	45
Studio Mode	80%	Appropriate speed to reduce dB levels >10% of full speed	NC35	40
Whisper Mode	60%	Appropriate speed to reduce dB levels >30% of full speed	NC25	35
Silent Mode	TBC	Fan off	NC15	25

NOISE CRITERION	OCTAVE BAND CENTER FREQUENCY (HZ)							
	63	125	250	500	1000	2000	4000	8000
	SOUND PRESSURE LEVELS (DB)							
NC-15	47	36	29	22	17	14	12	11
NC-20	51	40	33	26	22	19	17	16
NC-25	54	44	37	31	27	24	22	21
NC-30	57	48	41	35	31	29	28	27
NC-35	60	52	45	40	36	34	33	32
NC-40	64	56	50	45	41	39	38	37
NC-45	67	60	54	49	46	44	43	42
NC-50	71	64	58	54	51	49	48	47
NC-55	74	67	62	58	56	54	53	52
NC-60	77	71	67	63	61	59	58	57
NC-65	80	75	71	68	66	64	63	62
NC-70	83	79	75	72	71	70	69	68

vis_adm_fan-1k-jan

This page intentionally blank

TECHNICAL SUPPORT

GLOBAL 24HR TECHNICAL SUPPORT:

Call: +1 214 647 7880

entertainment.service@signify.com

NORTH AMERICA SUPPORT:

Call: 877-VARI-LITE (877-827-4583)

entertainment.service@signify.com

EUROPEAN CUSTOMER SERVICE:

entertainment.europe@signify.com

©2024 Signify Holding. All rights reserved.

All trademarks are owned by Signify Holding or their respective owners. The information provided herein is subject to change, without notice. Signify does not give any representation or warranty as to the accuracy or completeness of the information included herein and shall not be liable for any action in reliance thereon. The information presented in this document is not intended as any commercial offer and does not form part of any quotation or contract, unless otherwise agreed by Signify. Data subject to change.

VL800 EVENTPAR RGBA USER MANUAL

DOCUMENT NUMBER:

VERSION DATE:

JUNE 18 2024