



IPD-TSB2.0 PRODUCT SPECIFICATIONS

Recommended Power	PoE, Poe+, 40W PoE or 24V barrel connector
Frequency Response ± 3dB	85 Hz - 20 kHz
Frequency Response ± 10dB	65 Hz - 20 kHz
Crossover Frequency	3.5 kHz
Max SPL @ 1M	100dB
Transducer - High Frequency Driver	Two 0.75" Silk Soft Dome
Transducer - Low Frequency Driver	Four 3" Polypropylene Cones & Four Bass Radiators w/NBR Surround
Input Connection	RJ45
Inputs	2 channel Dante/AES67
Grille	Black Powder-Coated Aluminum
Accessories Included	Wall-Mount Hardware, Horizontal Tabletop Stands
System Type	2-way Ultra Thin Dante/AES67 enabled PoE Soundbar
Audio Channels	2
Network Type: Low Pass	12dB per octave, 2nd order
Network Type: High Pass	12dB per octave, 2nd order
Enclosure Material	Extruded Aluminum
Color	Black (Paintable)
Height	6.75 in (171.5 mm)
Width	43 in (1092.2 mm)
Depth	2.5 in (63.5 mm) (1.5 in [38.1mm] where the Soundbar meets the TV)
Packaging	One per box
Regulatory - UL	UL62368 Listed
Regulatory - CE	Approved
RoHS	Approved
Weight	15 lbs (6.8 kg)
Shipping Weight	17 lbs (77.3 kg)

Description

An ultra-thin 2-way Dante-enabled digital end-point solution in a soundbar configuration. The IPD-TSB2.0 brings Dante connectivity from end to end in conferencing and boardroom video installations. Making the soundbar interoperable with other Dante products gives integrators additional flexibility when designing and installing audio systems.

Built with high-quality materials and stylish brushed metal cosmetics, the IPD-TSB2.0 Soundbar is a reliable, unrivaled solution for any audio/video system. With digital signals plus PoE power sent directly to the speakers via standard category cable, SoundTube's STNet Soundbar is simple to connect. The intelligent amplifier with DSP monitors the functions of the speaker and can send an alert if there are any problems with the SoundBar.

Each IPD-TSB2.0 is configurable using SoundTube STNet Control Center software. The software is used to setup the SoundBar via an 8 band parametric EQ, delay and input and output gain using a built in pink noise generator. Because they are on the Dante platform, they are interoperable with a host of other products worldwide. They may be used with SoundTube's ST-Net Switch, offering up to 40 watts PoE to each speaker, or with standard PoE or PoE+ switches.

Features

- Dante PoE enabled and fully compatible
- UL Certified
- Fits beneath 50-in screen or larger
- 1.5-in depth where soundbar meets the TV
- L/R with four 3-in ultra-long throw polypropylene woofers with butyl rubber surrounds
- Four bass radiators
- Two 0.75-in soft dome tweeters
- Brushed black finish
- Wall and surface mount accessories included

Applications

Conference Rooms, Lobbies, Waiting Rooms, or Common Areas, Hotels, Corporate Buildings, Offices, and more

Patented Technologies

SoundTube, an MSE Audio brand, constantly develops new technologies which enhance audio product performance. SoundTube Entertainment innovations are protected by multiple U.S. and international patents, which explicitly cover SoundTube dome, enclosure and dispersion technologies. MSE Audio actively defends its patents in order to protect resellers and consumers.

Architectural Specifications

The loudspeaker shall consist of four 76.2 mm (in)

MSE Audio®

13720 W. 109th St.
Lenexa, KS 66215
Phone: 913.663.5600
Fax: 913.663.3200
Toll Free: 855.663.5600
www.mseaudio.com

All SoundTube speakers come with a 5-year limited warranty and 3-year warranty on all electronics.

Wall Mount:

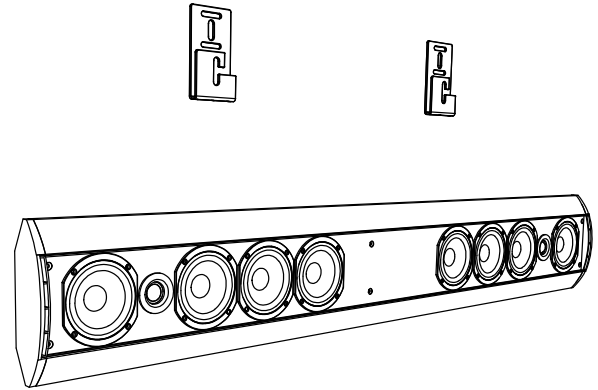

Table Top Mount (Front):

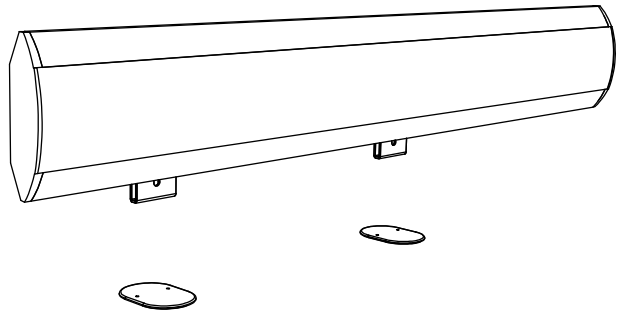
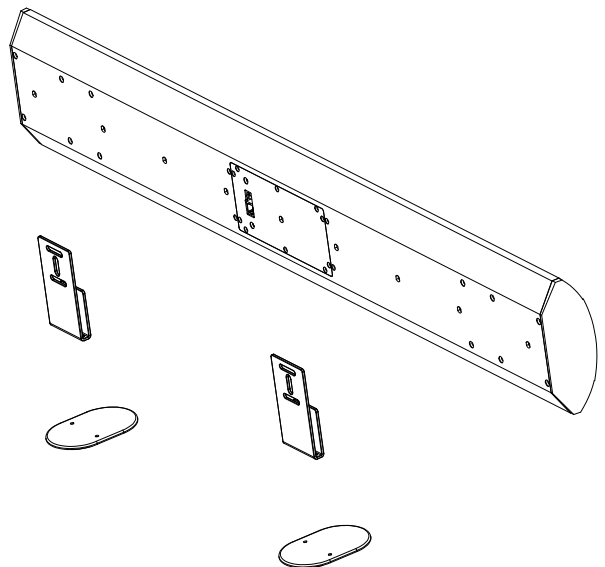
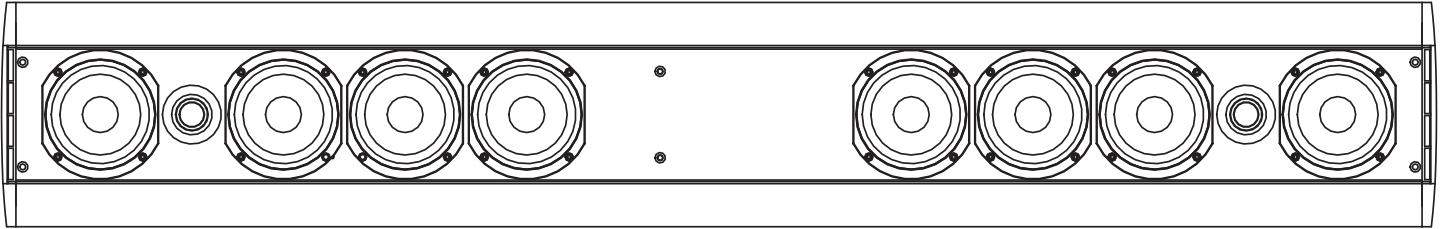

Table Top Mount (Back):



Mechanical Drawings

Front:



Back:

