

# Product Catalog 2023



**CITY**  
**THEATRICAL**  
NEW YORK • LONDON

# What's New?

Welcome to City Theatrical's Product Catalog!

We specialize in unique lighting accessories that make entertainment lighting projects and architectural installations easier and more creative. We provide a range of products, tools, software, and services that can't be found anywhere else. Our motto is: "Invent, Manufacture, and Customize". We do that every day in our beautiful manufacturing facility in Carlstadt, New Jersey.

Our vision of the new lighting world is that every DMX device will contain a tiny, inexpensive, Multiverse® Module, and where legacy lighting products have a Multiverse Receiver near them, allowing entire productions of hundreds of fixtures and dozens of universes to be operated using a reliable wireless DMX system. Our revolutionary Multiverse wireless DMX/RDM family provides lighting users with a new range of options for performing lighting tasks more easily than ever, while producing less disruptive radio energy.

QolorFLEX® is the single source for high quality, durable LED products that work together seamlessly, encompassing a vast collection of professional-grade LED tape products, dimmers, and accessories. All QolorFLEX products, including QolorFLEX HiQ High CRI and 5-in-1 LED Tapes, QolorPIX® Pixel Controlled LED Tape and Tape Controller, and QolorFLEX NuNeon®, are easy to work with, vibrant, and consistently color matched to meet the needs of lighting and scenic professionals working in theatrical, film and video, and architectural applications.

DMXcat® Multi Function Test Tool that makes it easy for anyone to control, analyze, or test any DMX lighting fixture, whether it's a simple LED PAR or a complex moving light. The multi award-winning DMXcat system consists of a small hardware dongle and a suite of mobile applications. Together, they bring wireless DMX and RDM control plus other useful functions to the user's smartphone.

For more information on our products, including detailed specifications, user manuals, videos, white papers, and case studies, please visit our website:  
[www.citytheatrical.com](http://www.citytheatrical.com)

Follow our social media pages for more information on a wide variety of lighting topics.

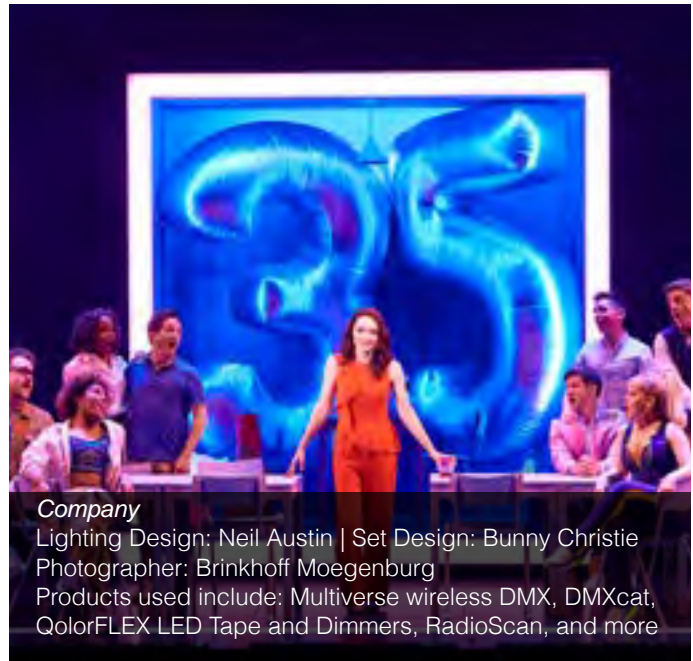

## Company

Lighting Design: Neil Austin | Set Design: Bunny Christie  
Photographer: Brinkhoff Moegenburg  
Products used include: Multiverse wireless DMX, DMXcat, QolorFLEX LED Tape and Dimmers, RadioScan, and more

## Thanks

City Theatrical would like to thank the following designers and inventors for allowing us to manufacture or distribute products from their ideas. We salute them for their creativity.

Jules Fisher	BeamBender™
Jules Fisher, Peggy Eisenhower, & Vivien Leone	Moving Light Accessories
Chris Lewton & Allen Lee Hughes	Drop-In Boomerang
LeMark	Blacktak™
Terry Richardson	Follow Spot Handle
Future Light Inc.	C-Clip Truss Protector™
Lori Friedlander	Image Multiplexer™
Mike Baldassari	Stackers™
Noele Stollmack	for many good ideas
Kenneth Posner	Follow Spot Yoke and RGB Indigo LED tape
Martin Chisnall	for many good ideas
Alan Crawshaw	for hanging hardware and for many good ideas
Philip Nye	for many projects and good ideas
Andrew Voller	Moving Light Assistant™
Bryn Williams	QolorPIX®

**Electronic .....2**

**Professional Lighting Software.....45**

**Beam Control .....47**

**Hardware .....61**

## Index

10" Boom Base.....	62	Moving Light Assistant™.....	46
Adapter.....	55	Moving Light Hangers.....	64
AquaFog 3300™.....	42	Multiverse® Wireless DMX/RDM.....	3
Barndoors.....	55	Multiverse Module.....	5
Beam Bender.....	58	Multiverse Node.....	7
Blacktak™ Light Mask Foil.....	58	Multiverse Receiver Card.....	5
Boom Tie Off.....	62	Multiverse SHoW Baby®.....	6
Breakaways.....	67	Multiverse Studio Add On Kit.....	12
Broadway Music Stand Light.....	44	Multiverse Studio Kit.....	11
Cable Hook.....	63	Multiverse Studio Receiver.....	10
Candle Lite™ Unlimited.....	43	Multiverse Transmitter.....	8
C-Clip Truss Protector™.....	62	Multiverse Vero Transceiver.....	9
Ceiling Port for Source Four PAR.....	62	Projector Dowser.....	44
CHAUVET Accessories.....	57	QolorFLEX® LED Tape.....	20
Color Extenders.....	54	QolorFLEX LED Tape Accessories.....	24
Color Force™ Accessories.....	60	QolorFLEX LED Dimmer Accessories.....	36
Color Frames.....	52	QolorFLEX LED Dimmers.....	30
Concentric Rings.....	54	QolorFLEX NuNeon®.....	26
DMXcat®.....	17	QolorFLEX NuNeon Accessories.....	27
Donuts.....	54	QolorPIX® Pixel Controlled LED Tape.....	28
Drop In Iris.....	55	QolorPIX Tape Controller.....	29
Egg Crate Louvers.....	54	QolorPoint® Wireless LED Uplighter.....	38
ETC® and High End Systems Accessories.....	57	RadioScan® Spectrum Analyzer.....	16
ETC S4 Series 3 LED Accessories Size Chart.....	48	Safer Sidearms™.....	66
ETC S4 LED Cyc Base.....	62	Scenery Bumper.....	63
Fog Accessories.....	42	Sliding Tee.....	63
Follow Spot Accessories.....	59	Stackers™ Tapered Top Hats.....	49
Follow Spot Drop In Boomerang.....	59	Source Four PAR Cross Baffle Top Hat.....	55
Follow Spot Yoke.....	58	Standard Half Top Hat.....	51
Gobo Holders.....	53	Standard Top Hat.....	50
GLP® Accessories.....	57	Track Tamers™.....	65
Image Multiplexer™.....	55	Vari-Lite® Accessories.....	57
LED Power Supplies.....	39	Vertical Extension Tubes.....	63
Lighting Shield.....	59	Wireless DMX / RDM.....	3
Mainframes®.....	52	Wireless DMX Accessories.....	13
Martin® Accessories.....	56	Wireless LED Event Lighting.....	38

# Wireless DMX: Yesterday's Challenges

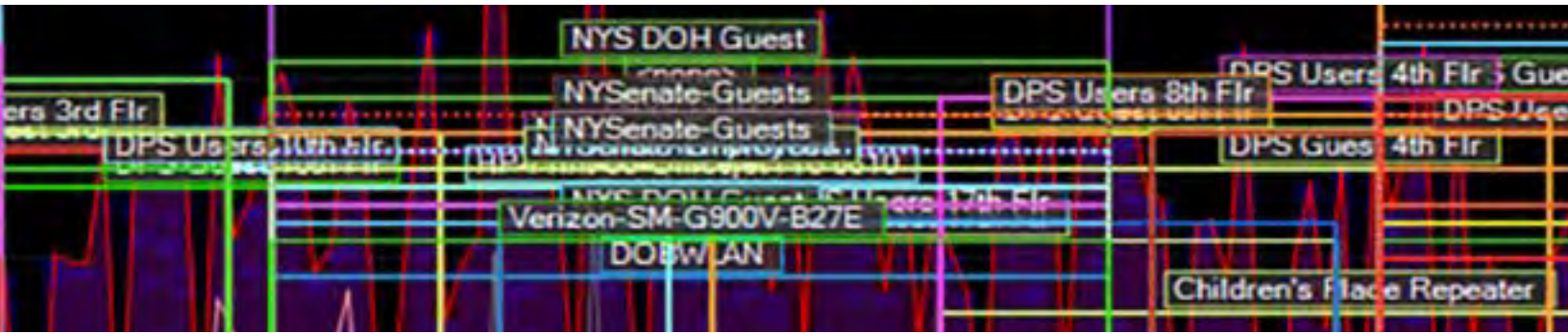

**Wireless DMX has played an important part in the lighting world since the early 2000s.** Many shows have used it on some scale because it has allowed lighting to be accomplished without running data cables. That can save time and money, and in some cases, such as for moving scenery, makes it possible to accomplish lighting effects that would have been impossible otherwise.

Simply stated, wireless DMX is a way of getting DMX data from “point A to point B” without using a cable.

## Why couldn't all DMX data be sent wirelessly in the past?

In some cases, such as small shows or limited uses, it can. The challenges begin as we attempt to **scale up** to larger and larger systems.

Each present day wireless DMX transmitter typically carries one “universe” of DMX data (512 DMX channels, or slots), which can operate 512 very simple lighting devices (this is rare) or a smaller number of more complicated devices which require a larger number of DMX slots to operate. Each wireless DMX transmitter produces radio energy that fills the 2.4GHz spectrum of the venue, competing for space in that crowded radio band with other devices.

**Each additional wireless DMX transmitter that is added creates more radio energy, until the spectrum is overwhelmed with radio energy, radio fidelity suffers, and the system collapses like a house of cards.**

Lighting fades may appear steppy, or even stop completely, and other 2.4GHz devices in the venue are negatively affected. This has prevented larger systems from being used wirelessly, and has stifled the growth and use of wireless DMX.

**To mitigate these interference problems, adaptive frequency hopping was an early strategy** among wireless DMX manufacturers to direct their signals to slivers of open unobstructed spectrum in the 2.4GHz band.

Unfortunately, **in a crowded radio spectrum**, there are no open spaces so the adaptive hoppers end up hopping on top of other radio signals. Adaptive hoppers are not a viable solution for scaling up to higher universe counts in a crowded spectrum.

**Two other factors have slowed or prevented the growth of wireless DMX.**

The first is **cost**. Each wireless DMX transceiver (a device that can be made to either be a transmitter or a receiver) costs between approximately \$350 and \$1,300 and many productions require multiple transceivers. In large systems, that cost can add up and it has been a limiting factor to the growth of wireless DMX.

The other factor is **trust**. Many users have felt that since the radio spectrum can't be seen (without specialized analysis tools beyond the reach of most everyday users) it might not be safe to trust their show to a wireless system, and that running data wires would be a safer option.

## So what is different now?

# Wireless DMX: Today's Solution



## Expanding the World of Wireless DMX

After 20 years of pioneering wireless DMX and RDM for entertainment and architectural lighting, City Theatrical has developed its revolutionary **Multiverse® wireless DMX/RDM** system broadcasting as many as 10 universes of DMX/RDM data from a single transmitter, with the ability to use less radio energy than present-day single universe systems.

### Multiverse marks our fifth generation of engineering development.

All previous wireless DMX control systems have suffered from a basic limitation: they are only able to transmit and receive a few universes of DMX data before their radio energy overpowers the spectrum and prevents their signals, and the signals of other devices in the venue, from accomplishing their mission. With this constraint, large scale multiple universe wireless systems simply have not been possible to achieve. In addition, the broadcast spectrum in which DMX systems operate has become overcrowded with other radio signals causing additional interference issues.

Faced with these challenges, we began to plan a new system of wireless lighting control that could be scaled up to unprecedented levels without overpowering the spectrum. Our mission therefore was to be able to deliver more data using less radio energy.

### Solution: Multiverse Module

We achieved our goal with the creation of our Multiverse Module. Every product in the Multiverse wireless DMX system is built around these tiny circuit board mounted devices, as an embodiment of this breakthrough technology.



### Key Features and Benefits

#### Flexibility & Scalability

Multiverse components can be set up as single or multiple universe configurations. Using our plug and play wireless Multiverse SHoW Baby or Multiverse Nodes, single universe systems can be created quickly and easily. Using a single Multiverse Transmitter, you can create a system of up to 10 universes.

#### Ease of Use

Components are easily set up and users can configure their system and then control its fixtures using Streaming ACN or Art-Net, or convenient smartphone based interfaces such as our DMXcat Bluetooth app or other Wi-Fi controllers, like Luminair.

#### 2.4GHz & 900MHz Operation

2.4GHz operation is usable worldwide, and for the first time, Multiverse users in the Americas can use a combination of 2.4GHz and 900MHz frequencies. *(Note: 900MHz is not licensed for use outside of the Americas.)*

#### PoE (Power over Ethernet)

Power the Multiverse Transmitter and receive sACN at the same time, without a power cord or external DC adaptor.

#### Backwards Compatibility

Multiverse products can be used seamlessly with highly popular City Theatrical legacy wireless DMX products, including SHoW DMX SHoW Baby®, SHoW DMX Neo®, and SHoW DMX Vero® and SHoW DMX Vero Net®.

#### RadioScan® Spectrum Analyzer

RadioScan can help improve all Multiverse broadcasts by helping the user select the optimum area in the spectrum to place their broadcast. RadioScan coordinates with Multiverse to help select optimum SHoW IDs.

## More Data Using Less Radio Energy

800.230.9497 or 201.549.1160

# Benefits of Multiverse Wireless DMX/RDM

Multiverse's patent-pending wireless DMX/RDM technology enables scalability of wireless lighting data like never before. It allows larger and larger systems to be scaled up without producing harmful amounts of radio energy that could disrupt other wireless systems in the venue, as well as innovative features which include simultaneous dual band operation, mDMX, mRDM, SHoW Key security, lock PIN, smartphone control, forward error correction, RadioScan, RDM integration, and low cost technology.



## More DMX Data, Less Radio Energy

Multiverse wireless DMX/RDM Transmitters can broadcast up to ten universes of DMX data while using less radio energy than other single universe wireless DMX transmitters.



## Smartphone Control

Multiverse Transmitter allows smartphone control of Multiverse equipped lighting fixtures by use of our free DMXcat app.



## Simultaneous Dual Band Operation

Broadcast on the 2.4GHz band and 900MHz band (licensed for use in North America only) at the same time, to broadcast as many of nine universes of wireless DMX/RDM.



## Forward Error Correction

Allows the Receiver to detect and correct errors that may occur in the wireless transmission of data.



## mDMX

mDMX is a form of DMX optimized for wireless broadcast that dramatically reduces data being broadcast, thereby reducing unneeded radio energy.



## RadioScan

The RadioScan® Spectrum Analyzer works with Multiverse and guides the user to the best area or the spectrum to place their broadcast.



## mRDM

Multiverse is able to broadcast RDM information without disrupting the DMX broadcast, a feature unique to Multiverse.



## RDM Integration

When Multiverse radios are implemented by a manufacturer of a lighting fixture, they become an integrated part of that device.



## SHoW Key Security

SHoW Key is an additional three-digit code that can be added to the Multiverse SHoW ID to prevent any other system on the same SHoW ID from interfering with your system.



## Low Cost Technology

Multiverse Modules are the lowest cost full featured DMX/RDM product ever, making them ideal for lighting manufacturers.



## Lock PIN

When using a smartphone with the DMXcat® app, a four-digit PIN can be applied to the Multiverse Transmitter for authorized users.

## Multiverse Module

P/N	Frequency
5990	900MHz
5991	900MHz
5994	2.4GHz
5995	2.4GHz



Shown at actual size.

## For OEM Partners

**Multiverse® Modules are best suited for lighting equipment manufacturers who are interested in adding wireless DMX to their products.**

Due to low cost, increased data transport, and ease of design integration, Multiverse Module marks the first time the implementation of a wireless DMX chip in every DMX device is possible. The Multiverse Module is available in two frequency ranges, 900MHz (for use in North America) and 2.4GHz (for use worldwide). Each frequency version can include a PCB trace antenna or not. All versions have a U.FL connector to connect to an external antenna.

Multiverse Modules are available on reels for surface mounting. The OEM Implementation Kit includes a detailed guide, equipment, test gear and more. Contact us for more information.

## Multiverse Receiver Card

P/N	Frequency
5906	2.4GHz
5907	900MHz

Shown at actual size.

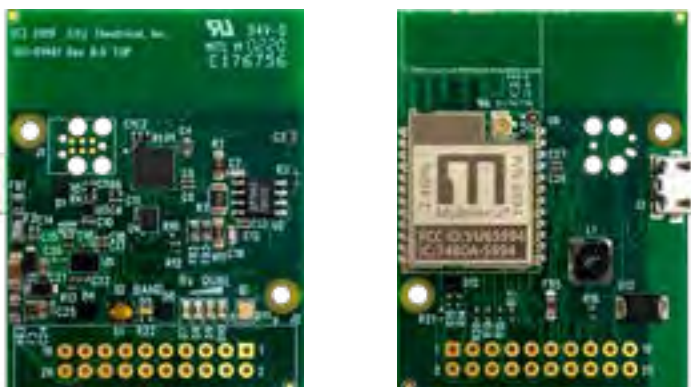

**Multiverse Receiver Cards are products that any lighting user, including manufacturers with low volume products, can use to implement wireless DMX/RDM into entertainment projects or equipment, including props, costumes, or lighting fixtures, in a simple way.**

Multiverse Receiver Cards are full Multiverse wireless DMX/RDM receivers without the housing, XLR connectors, and user interface as used in wireless DMX receiving products like the Multiverse Node and Multiverse SHoW Baby. Multiverse Receiver Cards include an internal and a connection to an optional external antenna. Configuration for Multiverse Receiver Cards is done via RDM with the DMXcat app, or with City Theatrical's USB Configuration Program for PC/Mac. In addition to receiving wireless DMX and outputting wired DMX, the Multiverse Receiver Card can output 0-10V, and has four PWM control outputs.

## Implement Wireless DMX/RDM Into Lighting Equipment In A Simple Way

### Key Features

- Supports ANSI E1.11 DMX512-A and E1.20 RDM
- DMX RS-485 driver on board with  $\pm 60V$  protection
- Signal Quality LEDs on board and external connections
- SHoW ID RGB LED on board and external connections
- Multiverse Band LED on board and external connections
- Wide input voltage range, 5V to 30Vdc
- Footprint 50mm(2") x 38mm(1.5")
- +3.3Vdc output to power low current hosts
- Configurable over USB micro B connector
- Firmware updatable over USB micro B connector
- Advanced Mode features: 0-10V output; Four PWM control outputs



# Multiverse SHoW Baby

P/N	Frequency
5900	2.4GHz



**Right out of the box, Multiverse® SHoW Baby® is compatible with all SHoW Babys ever made.**

With tens of thousands of units sold since their introduction in 2011, SHoW Baby plug and play transceivers set the standard for ease of use and reliability at an affordable price point. The addition of Multiverse radio technology enhances their performance even more.

City Theatrical's Multiverse SHoW Baby is a wireless DMX transceiver that delivers breakthrough plug and play wireless DMX and RDM transmission. In its default mode, it works like all other SHoW Baby Transceivers with six user selectable SHoW IDs. By connecting an RDM controller, like DMXcat® Multi Function Test Tool, all of the revolutionary 2.4GHz Multiverse SHoW IDs are accessible. Users can add to their existing SHoW Baby systems, build new single universe Multiverse systems, or use Multiverse SHoW Baby as a receiver on multiple universe systems with a Multiverse Transmitter.

## The Fourth Generation of the Original Plug and Play Wireless DMX Transceiver System

### Key Features

- Built-in 2.4GHz Multiverse radio (for worldwide use)
- All SHoW DMX Neo and 2.4 GHz Multiverse SHoW IDs are available through RDM
- In Multiverse mode, compatible with all Multiverse products. In SHoW DMX Neo mode, compatible with all SHoW DMX Neo legacy products.
- Plug and Play selection of Transmitter or Receiver function
- 5 Pin XLR DMX input and output
- 5 to 30VDC power input
- Molded plastic enclosure

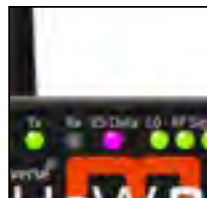

Transmitter set to SHoW ID 117

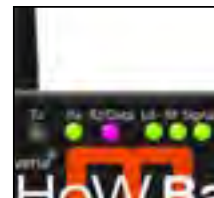

Receiver set to same SHoW ID



Set SHoW IDs on back of unit

### What's in the box:



### Tx SCHEMATIC

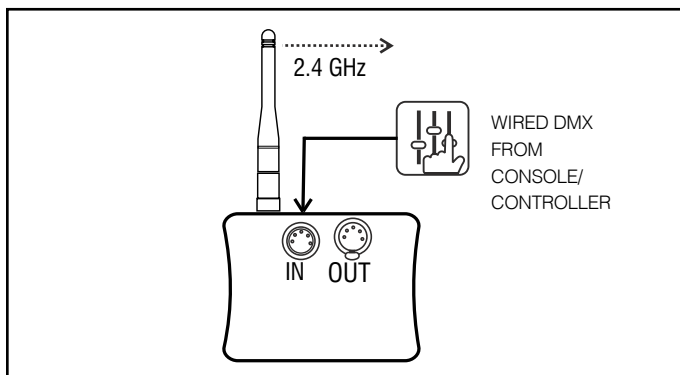

### Rx SCHEMATIC

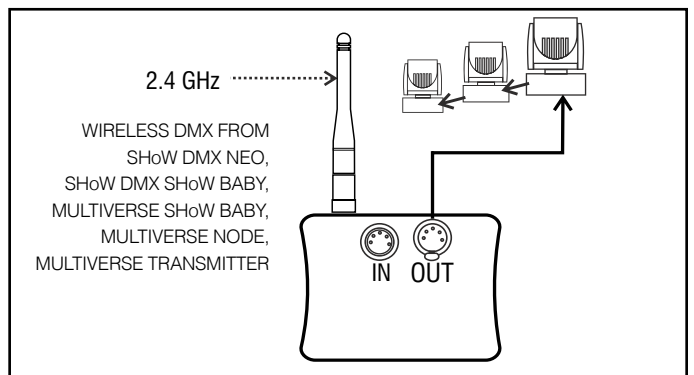



# Multiverse Node

P/N	Frequency
5902	900MHz/2.4GHz
5903	2.4GHz



**The Multiverse® Node is the first building block of the Multiverse system.**

Each Multiverse Node is a transceiver. As a single universe transmitter, it functions in a similar plug and play manner to our Multiverse SHoW Baby®, but contains two radios (North America version only) and a full user interface. As a receiver, it is the primary single universe stand alone receiver in the Multiverse system, and can be part of a larger multi-universe setup.



Tx SCHEMATIC

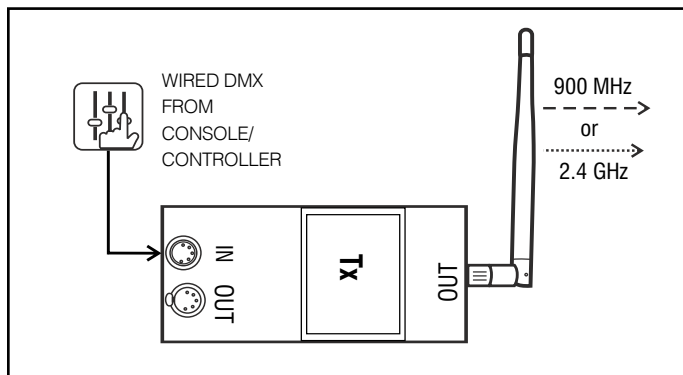

## Single Universe Plug and Play Simplicity

### Key Features

- Built-in 2.4GHz (for worldwide use) and 900MHz (for use in North America only) radios allow the user to select which single universe to transmit, and which radio band to use via the SHoW ID
- As a single universe receiver as part of a multi-universe system, users can select which universe to receive
- A very simple user interface to set SHoW ID and universe
- Rugged cast aluminum enclosure
- 5 Pin XLR DMX input and output
- 5 to 30VDC power input via locking barrel connector



Pipe Mount



Simple onboard setup



Back of unit

What's in the box:



Rx SCHEMATIC

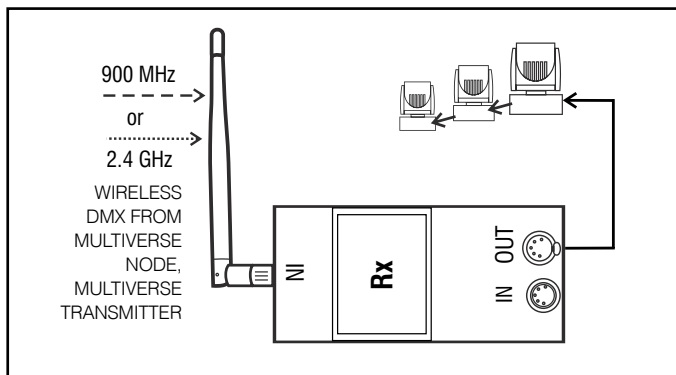

800.230.9497 or 201.549.1160

# Multiverse Transmitter

P/N	Frequency	Universes
5910	900MHz/2.4GHz	9
5911	2.4GHz (x2)	10
5912	900MHz (x2)	8



## The Multiverse® Transmitter opens a new world in wireless DMX/RDM.

Its Ethernet input allows it to take in Streaming ACN (sACN) or Art-Net and to transmit between eight and 10 user-selectable universes of DMX/RDM, depending on the Multiverse Transmitter used, with the ability to use less radio energy than a present day single universe wireless DMX transmitter.

The Multiverse Transmitter has a Bluetooth radio receiver built in that allows it to communicate with City Theatrical's multi award winning DMXcat® app from the user's smartphone. This gives the user smartphone control of any lighting fixture that is part of the Multiverse setup, whether it is a lighting fixture with a Multiverse Module inside, a lighting fixture receiving its data from a Multiverse Node, or any wired fixture downstream of those devices.

The Multiverse Transmitter is Wi-Fi enabled, allowing for communication and control from tablet based Wi-Fi lighting controllers like Luminair.

What's in the box:



## Multiple User Control Using Bluetooth Or Wi-Fi

### Key Features

- Four radios: Bluetooth and Wi-Fi for inputs, and two for Multiverse wireless DMX/RDM output: 900MHz and 2.4GHz (for P/N 5910), 2.4GHz and 2.4GHz (for P/N 5911), and 900MHz and 900MHz (for P/N 5912)
- Ethernet input for sACN and Art-Net
- All setup and user choices made with our free DMXcat app
- Rugged cast aluminum enclosure
- A hanging bracket is included for hanging from a pipe or truss
- Additional user control via DMXcat app or Luminair
- Power Input: AC, DC, PoE



Pipe Mount



Pipe Mount

### SCHEMATIC (FOR P/N 5910)

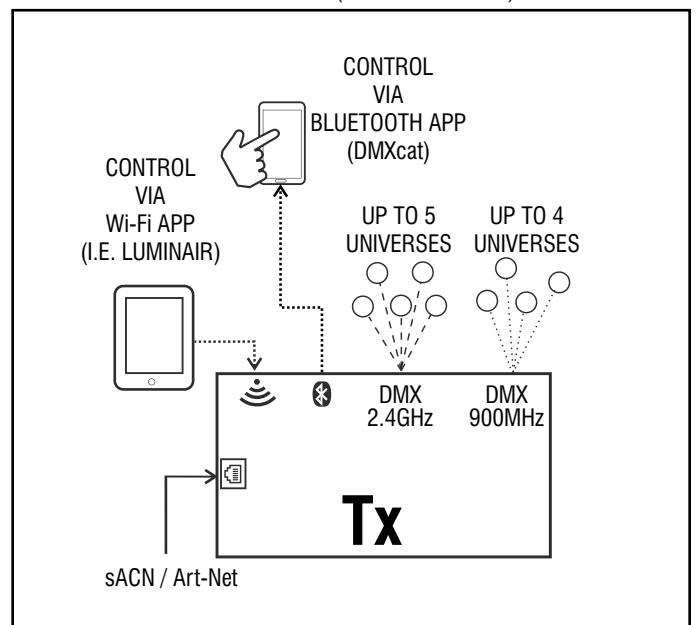

# Multiverse Vero Transceiver

P/N	Frequency
7400-5902	900MHz/2.4GHz
7400-5903	2.4GHz



**The Multiverse® Vero Transceiver brings the advanced features of the Multiverse wireless DMX/RDM system to outdoor installations for architecture and entertainment.**

The 7400-5902 Multiverse Vero Transceiver 900MHz/2.4GHz contains two radios, 2.4GHz (for worldwide use) and 900MHz (for use in the Americas only), which allow the user to select which single universe to receive, and which radio band to use via the Multiverse SHoW ID.

The Multiverse Vero Transceiver is housed in a NEMA 4/ IP66 package that provides protection from the outdoor elements. Its internal backlit LCD display makes setup easy and gives feedback on system performance. Each unit comes with a dual band 2.5dBi outdoor omni-directional.



## Outdoor-Rated Wireless DMX/RDM

### Key Features

- Built-in Multiverse 2.4GHz (for worldwide use) and 900MHz (for use in the Americas only) Frequency Hopping Spread Spectrum radio
- Compatible with all Multiverse and legacy SHoW DMX Neo products
- User can select a single universe to receive
- Four button user interface screen to set SHoW ID, universe, and other functions
- DMX In (when used as transmitter) and Out (when used as receiver) via 3 pin Screw Terminal
- Rugged weatherproof aluminum enclosure
- Omni Broadband antenna, 900MHz/2.4GHz, 2.5dBi/2.5dBi



Wall Mount



Pipe Mount

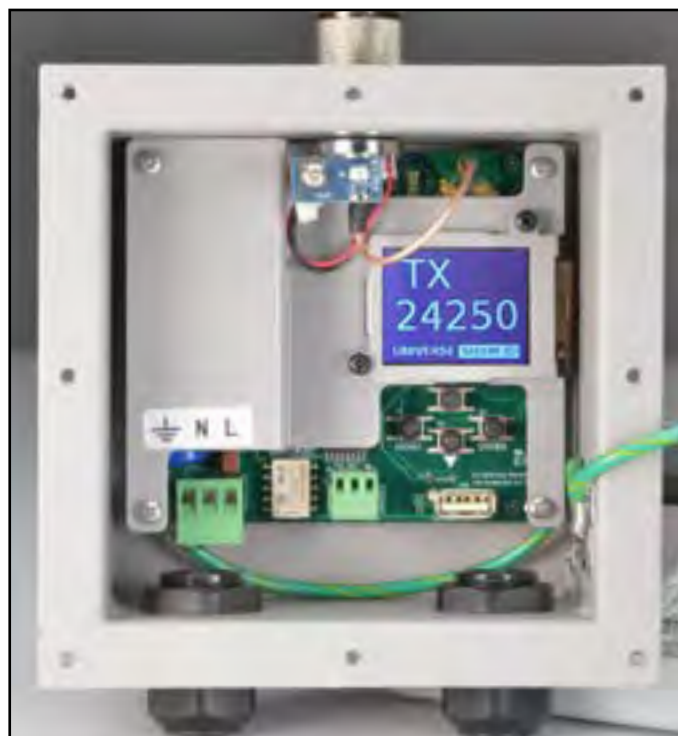

# Multiverse Studio Receiver

P/N	Frequency	Universes
5904	900MHz/2.4GHz	1
5905	2.4GHz	1



**The Multiverse Studio Receiver brings the advanced features of the Multiverse wireless DMX/RDM system to the film and video world, where fast setup and reliability are key objectives.**

The Multiverse Studio Receiver contains a long-life lithium-ion polymer battery giving 20 hours of use. The Multiverse Studio Receiver has a full four button user interface with a backlit LED display that makes setup easy and gives feedback on system performance.

The 5904 Multiverse Studio Receiver contains two built-in radios, 2.4GHz (for worldwide use) and 900MHz (for use in the Americas only), and the 5905 Multiverse Studio Receiver contains a 2.4GHz radio, which allow the user to select which single universe to receive, and which radio band to use via the Multiverse SHoW ID.

The DMX corded connector allows the Multiverse Studio Receiver and external to hang below the lighting fixture, giving improved data fidelity.

*What's in the box:*



\*The P/N 5969 External Power Supply, 100-240VAC input, 5VDC output USB-A shown comes with the P/N 5904 Multiverse Studio Receiver 900MHz/2.4GHz model only.

## 20-Hour Battery Life Wireless DMX Receivers Designed for Film, Video, and Events



### Key Features

- Choice of Broadcast Radio: Transmit and receive on either the 2.4GHz band or the 900MHz band. (P/N 5905 transmits and receives on the 2.4GHz band only.)
- Long Life Rechargeable Battery: 20 hour battery life with default settings
- Rugged and Splashproof: An IP61 rated plastic case, making it splashproof and rainproof (but not for permanent outdoor use).
- User Selectable SHoW IDs: City Theatrical has always produced wireless DMX products that allow the user to select the optimum transmission method. Users may select full bandwidth hopping, hopping limited to a section of the spectrum (including areas of the spectrum outside of the Wi-Fi range), or adaptive hopping.



## Multiverse Studio Kit

P/N	Frequency	Universes
5938	900MHz/2.4GHz	1 - 9
5939	2.4GHz	1 - 10

All the Tools Lighting Technicians Need to Quickly Plan, Setup, and Operate Wireless DMX/RDM for Film, Video, and Events



The Multiverse Studio Kit brings the advanced technology of Multiverse wireless DMX/RDM system to the film and video world, featuring Receivers with 20 hour battery life and contactless charging in an easy to use kit.

The Multiverse Studio Kit provides all the tools lighting technicians need to quickly plan, setup, and operate wireless DMX/RDM on set. It includes:

- Six battery powered Multiverse Studio Receivers
- One Multiverse Transmitter with hanging bracket and clamp (for multi universe broadcasts)
- One Multiverse Node with hanging bracket and clamp (for single universe broadcasts)
- One DMXcat Multi-Function Test Tool (to turn on and troubleshoot any lighting fixture on set)
- One RadioScan Spectrum Analyzer (for broadcast planning)
- Six USB-A to USB-C cable, 1m
- Six Power Supplies, 100-240VAC input, 5VDC output\*
- One Power Cord, PowerCON True 1, 8' long
- Pelican case with contactless charging

Just drop the Multiverse Studio Receiver onto its slot in the Multiverse Studio Kit case, and it will begin charging. Individual chargers and USB cables are also included to enable charging or powering individual units outside the case.



Multiverse Studio Receivers charging in the Multiverse Studio Kit.

\*External power supplies only come with the P/N 5938 model.

# Multiverse Studio Add On Kit

P/N	Frequency	Universes
5940	900MHz/2.4GHz	1 - 9
5941	2.4GHz	1 - 10

## Add Receivers to a Multiverse Studio Kit System in a Contactless Charging Case



### Expand your Multiverse Studio Kit

The Multiverse Studio Add On Kit provides six additional Multiverse Studio Receivers for users to expand upon their full P/N 5938/5939 Multiverse Studio Kits.

Just drop the Multiverse Studio Receiver onto its slot in the Multiverse Studio Add On Kit case, and it will begin charging. Individual chargers and USB cables are also included to enable charging or powering individual units outside the case.

Each Add On Kit includes:











- Six Multiverse Studio Receivers
- Six USB-A to USB-C cable, 1m
- Six Power Supplies, 100-240VAC input, 5VDC output\*
- One Power Cord, PowerCON True 1, 8' long
- Pelican case with contactless charging



Multiverse Studio Receivers charging in the Multiverse Studio Add On Kit.

\*External power supplies only come with the P/N 5940 model.

# Wireless DMX Accessories

	P/N	NAME	FOR PRODUCT
<b>STANDARD ANTENNAS:</b> 	5729	2dBi Indoor Omni Antenna, 2.3"	All SHoW Baby models
	5731	4dBi Indoor Omni	Legacy SHoW DMX Neo Transmitter and Receiver
	 5980	2dBi/4dBi Omni Broadband Antenna, 900MHz/2.4GHz, Dual Band	Multiverse Module, Multiverse Node, and Multiverse Transmitter
	 5983	2.5dBi/2.5dBi Omni Broadband Antenna, 900MHz/2.4GHz, Dual Band Outdoor	Multiverse Vero Transceiver
	 5984	1.8dBi/3.8dBi Omni Broadband Antenna, 900MHz/2.4GHz, Dual Band Stubby	Multiverse Studio Receiver
<b>LONG RANGE ANTENNAS:</b> 	5981	Panel, Dual Band 900MHz - 2.4GHz (See City Theatrical website for adapter cables needed.)	Multiverse Node and Multiverse Transmitter
	5982	Yagi, Dual Band 900MHz - 2.4 GHz (See City Theatrical website for adapter cables needed.)	Multiverse Node and Multiverse Transmitter
<b>ACCESSORIES:</b> 	5637	Splitter	All Panel and Yagi antennas
	5638	Adapter Cable	Panel and Yagi to SHoW Baby, Multiverse Node, and Multiverse Transmitter
	5639	Gender Changer for 5637 Splitter	Two needed for each Splitter (P/N 5637)
	5641	Antenna Adapter Cable, N (M) to (N) M, 36"	Multiverse Vero Transceiver and legacy SHoW DMX Vero and Vero Net products
<b>POWER SUPPLIES:</b> 	5627	SHoW DMX Power Supply	SHoW Baby, SHoW DMX Transmitter and Receiver
	5972	Power Supply, 12V, 6W, 5.5x2.1mm, Locking	Multiverse Node and Multiverse Transmitter
<b>HANGING BRACKETS:</b> 	5602	SHoW DMX Mounting Plate (not shown)	SHoW DMX Transmitter and Receiver
	5780	SHoW Baby Hanging Bracket	All SHoW Baby models
	5971	Multiverse Node Hanging Bracket	Multiverse Node
	5974	Multiverse Transmitter Hanging Bracket	Multiverse Transmitter
<b>POWER CORDS:</b> 	5973	Multiverse Node USB Power Cable	Multiverse Node
	5840	N5-15P to powerCON TRUE1, 12AWG, 8'	Multiverse Transmitter
	103-00730	Cable, Coax U.FL(L10-iPEX) to RP-SMA Jack 5", OD1.37mm	Multiverse Module and Multiverse Receiver Card
<b>CONNECTORS:</b> 	5970	Multiverse Locking Barrel Connector Lead, 6"	Multiverse Node

**800.230.9497 or 201.549.1160**

# Multiverse Receiver / Transmitter Specifications



	<b>Multiverse Receiver Card</b>	<b>Multiverse SHoW Baby</b>	<b>Multiverse Node</b>
<b>Part Number</b>	5906 (2.4GHz), 5907 (900MHz*)	5900 (2.4GHz)	5902 (900MHz*/2.4GHz), 5903 (2.4GHz)
<b>Applications</b>	Indoor	Indoor	Indoor
<b>Broadcast Power</b>	2.5mW, 8mW, 25mW, 80mW	2.5mW, 8mW, 25mW, 80mW	3.2mW, 10mW, 32mW, 100mW
<b>Antenna(s)</b>	External U.fl connector or Internal	2dBi omni	Omni broadband, 900MHz/2.4GHz, 2dBi/4dBi
<b>User Interface</b>	DMXcat app or USB Configurator	One Button / Indicator Lights	4 Button / Backlit LED Display
<b>Broadcast Modes</b>	Adaptive, Full, Low, Mid, High, Max	Adaptive, Full, Low, Mid, High, Max	Adaptive, Full, Low, Mid, High, Max
<b>Ethernet Protocols</b>	N/A	N/A	N/A
<b>Hopping Patterns</b>	10	10	10
<b>Show IDs</b>	217 (P/N 5906); 90 (P/N 5907)	217	307 (P/N 5902); 217 (P/N 5903)
<b>Latency</b>	4ms average	4ms average	4ms average
<b>RF Sensitivity</b>	-95dBm	-95dBm	-95dBm
<b>RDM Features</b>	RDM Proxy, RDM Responder	RDM Proxy, RDM Responder	RDM Proxy, RDM Responder
<b>Compliance</b>	Pre compliance reports available for integrators	FCC, IC, CE, ARIB, RoHS	5902: FCC, IC 5903: FCC, IC, CE, ACMA, ARIB, RoHS
<b>Power Input</b>	5-30VDC, 0.44W	5-30VDC, 1W	5-30VDC, 1W
<b>Power Connector</b>	20-Pin 2x10 0.100-inch header, male	5.5mm x 2.1mm, center positive, 9mm mating depth	Locking DC Jack, 5.5mm x 2.1mm, center positive, 12.1mm mating depth
<b>IP Rating</b>	N/A	IP50	IP50
<b>Construction</b>	PCB Assembly	Injection Molded Plastic	Die Cast Aluminum
<b>Dimensions</b> (L x W x H)	2.0" x 1.5" x 0.25" (50 x 38 x 6.4mm)	3.625" x 3.0" x 1.8" (92 x 76 x 46mm)	4.05" x 2.36" x 1.44" (102.8 x 60 x 36.47mm)

Multiverse technology is covered by U.S. Patents #7,432,803 B2, #10,129,964 B1, and other patents pending.

See product manuals for complete specifications. Specifications may be subject to change.





	<b>Multiverse Vero Transceiver</b>	<b>Multiverse Studio Receiver</b>	<b>Multiverse Transmitter</b>
<b>Part Number</b>	7400-5902 (900MHz*/2.4GHz), 7400-5903 (2.4GHz)	5904 (900MHz*/2.4GHz), 5905 (2.4GHz)	5910 (900MHz*/2.4GHz), 5911 (2.4GHz (x2)), 5912 (900MHz* (x2))
<b>Applications</b>	Outdoor	Indoor, Outdoor (Splashproof)	Indoor
<b>Broadcast Power</b>	3.2mW, 10mW, 32mW, 100mW EIRP	3.2mW, 10mW, 32mW, 100mW EIRP	3.2mW, 10mW, 32mW, 100mW
<b>Antenna(s)</b>	Dual band 900MHz / 2.4GHz 2.5dBi / 2.5dBi Outdoor	Dual band 900MHz / 2.4GHz 1.8dBi / 3.8dBi Stubby	Omni broadband, 900MHz/2.4GHz, 2dBi/4dBi
<b>User Interface</b>	Internal Backlit LCD display	4 Button / Backlit LED Display	DMXcat app
<b>Broadcast Modes</b>	Adaptive, Full, Low, Mid, High, Max	Adaptive, Full, Low, Mid, High, Max	Adaptive, Full, Low, Mid, High, Max
<b>Ethernet Protocols</b>	N/A	N/A	802.11 bgn, 100 BASE-T sACN, Art-Net
<b>Hopping Patterns</b>	10	10	10
<b>Show IDs</b>	307 (P/N 7400-5902); 217 (P/N 7400-5903)	307 (P/N 5904); 217 (P/N 5905)	237 (P/N 5910); 147 (P/N 5911); 90 (P/N 5912)
<b>Latency</b>	4ms average	4ms average	4ms average
<b>RF Sensitivity</b>	-95dBm	-95dBm	-95dBm
<b>RDM Features</b>	RDM Proxy, RDM Responder	RDM Proxy, RDM Responder	RDM Proxy, RDM Responder
<b>Compliance</b>	7400-5902: FCC, IC, cETLus Listed 7400-5903: FCC, IC, CE, UKCA, ARIB, cETLus Listed, RoHS	5904: FCC, IC 5905: FCC, IC, CE, UKCA, ARIB, RoHS	5910/5912: FCC, IC, ETL 5911: FCC, IC, CE, ACMA, ARIB, cETLus Listed, RoHS, EAC
<b>Power Input</b>	90-277VAC input, 1A max	Internal battery; included external power supply 100- 240VAC input, 5VDC output	100-240VAC 50/60Hz, 5-30VDC, POE Class 0, 5W
<b>Power Connector</b>	3 pin screw terminals	USB-C connector	Locking DC Jack, 5.5mm x 2.1mm, center positive, 12.1mm mating depth; powerCON TRUE1 in/thru; EtherCON
<b>IP Rating</b>	IP66	IP61	IP50
<b>Construction</b>	NEMA 4 / IP66 Aluminum enclosure	ABS Plastic	Die Cast Aluminum
<b>Dimensions</b> (L x W x H)	6.5" x 6.0" x 4.0" (165 x 152 x 102mm)	5.5" x 1.812" x 1.0" (139.7 x 46 x 25.4mm)	7.75" x 4.0" x 1.85" (196.9 x 101.5 x 47mm)

\*900MHz band is licensed for use in North America only.

# RadioScan Spectrum Analyzer

P/N	Frequency
5988	902-928MHz and 2.4-2.483GHz



**RadioScan Spectrum Analyzer is a 900MHz and 2.4GHz spectrum analyzer that enables you to easily visualize radio energy that is otherwise invisible to you.**

Using RadioScan helps you to create a broadcast plan that optimizes available spectrum in your area, and helps prevent interference with other mission critical radio devices near you.

RadioScan shows all radio activity near you in your chosen frequency, including frequency hopping gear like wireless DMX, as well as Wi-Fi networks, Bluetooth, wireless headsets, video transmitters, cordless phones, baby monitors, and microwave ovens. RadioScan can view spectrum data either in Spectrogram View or Waterfall View, and snapshots can be taken of both in the program. Scans of any length can be recorded, saved, emailed and played back with the RadioScan software, without the need for the RadioScan hardware dongle.

For users of Multiverse® wireless DMX/RDM products, RadioScan will guide you in creating the optimum broadcast plan for your production.



**Easily Visualize Radio Energy and Create Broadcast Plans**



**RadioScan®**

## Key Features

- 900MHz and 2.4GHz spectrum analyzer with dual band
- Finds all radio activity nearby in chosen spectrum
- Identifies SSID and signal strength of Wi-Fi networks
- Shows either Spectrogram or Waterfall view
- Can record and play back scans of unlimited length
- Takes and saves snapshots
- Records text notes on scans
- Prompts Multiverse SHoW IDs

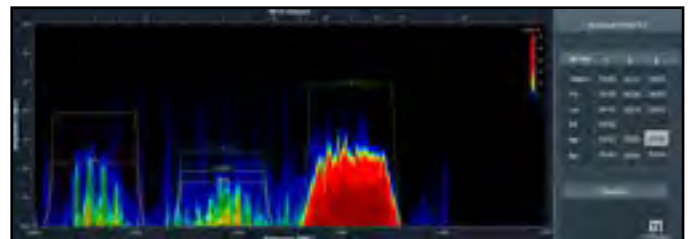
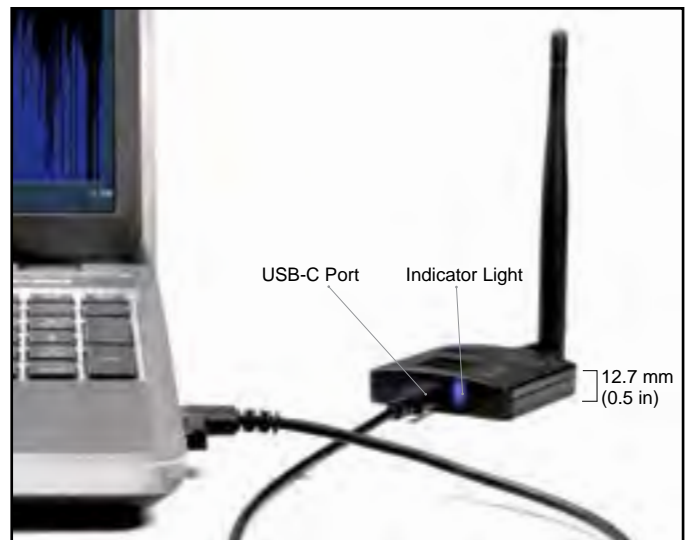

**DMXcat®**

Part Number: 6000

**DMXcat®**  
 CONTROL ANALYZE TEST

City Theatrical's DMXcat system is designed for use by the lighting professional who is involved with the planning, installation, operation, or maintenance of theatrical and studio lighting equipment. The system consists of a small interface device and a suite of mobile applications. Together, they combine to bring DMX/RDM control plus several other functions to the user's smartphone. DMXcat works with Android, iPhone, and Amazon Fire.

**Hardware**

The DMXcat's interface device is a compact battery powered unit which fits easily in a pocket or tool pouch or may be worn on a belt. It uses Bluetooth LE technology for communication with the smartphone/applications (up to 50' range). Without being physically connected, the user can move about the workspace and operate the various apps while still using the phone for on-the-job communication. The device's five pin XLR connector/cable assembly allows it to be connected to any point in a DMX data chain to allow testing and or control of the

various DMX/RDM slot functions. It is charged using a standard USB to Micro USB cable and charger.

Features include a built-in LED flashlight, an audible alarm (for locating a misplaced unit), an LED status indicator, an XLR5M to XLR5M Turnaround, and a removable belt clip. Optional accessories include: XLR5M to RJ45 Adapter, XLR5M to XLR3F Adapter, XLR5M to XLR3M Turnaround, and Belt Pouch.

**Mobile App**

DMXcat can function in seven languages: Spanish, French, German, Italian, Korean, Japanese, and English, depending on your mobile phone's native language setting.

**800.230.9497 or 201.549.1160**

# DMXcat Applications

## DMX Controller

The DMX Controller app is a flexible and feature rich means for controlling 512 channels of DMX data. Two different user interfaces are included. The first emulates a conventional slider control arrangement such as is found on many simple manual lighting controllers. Touch and swipe gestures control the various level adjustments. Users can work with and easily switch between screens displaying 8, 64, or 512 (Live View) channels of information. For those who prefer a numeric based interface similar to what is found on a full sized lighting console, command line instructions can be input using familiar keypad and thumbwheel controls. An active 16 channel display provides current channel status. With either interface, users can adjust/work with individual, groups, or ranges of channels, record and play presets, customize names, and display levels as %, decimal, or hex value.

## RDM Controller

The RDM Controller is an application designed to control RDM enabled fixtures. Features include:

- Control & monitoring of RDM devices
- Full discovery - detects and generates a list of all RDM devices.
- Detects all sub devices for a selected device
- Shows all supported parameters
- Shows descriptions for all PIDs
- GET and SET for all PIDs (even user defined)
- Monitors fixtures for any sensors with easy to view info.
- When connected to an RDM enabled fixture, DMXcat identifies the fixture's address and attributes and loads its control interface automatically.

## RF Spectrum Analyzer (Android only)

Identify potential communication problems before they happen. The RF Spectrum Analyzer enables the user to visualize existing Wi-Fi networks operating within a venue. Each wireless network is labeled and shown graphically within an overall schematic representation of the 2.4GHz RF channel spectrum. Armed with this information, wireless DMX operation can be optimized by adjusting the type of transmission (hopping patterns) and/or locating the control network in uncrowded or unused areas of the RF Spectrum.

## Fixture Controller

The Fixture Controller app has been designed to serve as a setup and test tool for the vast selection of lighting fixtures in use today. Many of today's moving light fixtures use over 40 channels of DMX control data, and can be configured to operate in a dozen or more modes (profiles). This can make it difficult to identify a particular channel's function when setting up or testing a fixture with a small DMX controller. Using an extensive built in database of manufacturers, fixtures, and operational profiles, users can easily select and assign the fixture's attributes and starting address, and a control interface specific to the fixture is displayed for testing its features. The various fixtures/personalities may be saved as "favorites" for future reference.

## Personality Editor

Found within the Fixture Controller app, the Personality Editor allows users to create custom personalities. Working from scratch or by modifying an existing personality, individual attributes are added as needed and then saved. Upon completion, the manufacturer name, fixture name, and personality name are added and the profile can be saved to a "favorites" database.

## DIP Switch Calculator

The DIP Switch Calculator app is an indispensable tool used in the conversion of numeric values to their binary equivalents. Used when configuring DIP switches for setting DMX channels and other fixture parameters, users simply enter a three digit numeric value and its corresponding DIP setting is displayed. Both the numbering order and reading direction can be reversed to match the switch orientation as needed.

## DMX Tester

Connect the DMXcat to a point in a DMX data chain and view DMX information and levels. Parameters of the controller's transmitted DMX signals may be adjusted and parameters of received DMX signals may be analyzed including: Break Time, Mark After Break, Inter-slot, Mark Before Break, Number Of Slots, and Refresh Rates. A Flicker-Finder function is included for identifying intermittent problems within the data network. The View Level function shows real time DMX levels sent from a console.

## Light Meter (Android only)

Useful for studio work, this app offers basic reflected light measurements to help in light level adjustment for film and video production. Light levels are displayed in LUX.

## Info

General product information, Hardware operation, App instructions and FAQs are all accessed here.

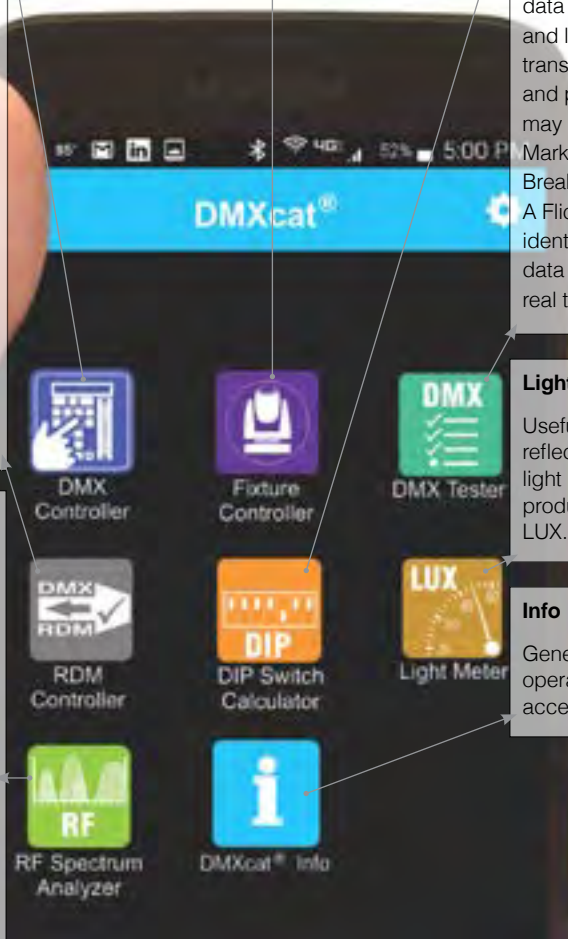

# DMXcat Specifications

<b>Part Number</b>	6000
<b>Wireless Communication</b>	Bluetooth LE
<b>Range</b>	50' (15m)
<b>Status LED indicator</b>	Yes, multicolor
<b>Flashlight</b>	White LED
<b>Charging Port</b>	Micro USB
<b>DMX Connection</b>	XLR5F
<b>Battery Run Time</b>	20 hours
<b>Charge Time</b>	8 hours
<b>Apps</b>	7 on Android and 5 on iOS, as follows: DMX Controller, Fixture Controller, DIP Switch Calculator, DMX Tester, RDM Controller, Light Meter (Android only), RF Spectrum Analyzer (Android only)
<b>Construction</b>	NEMA 1 ABS enclosure
<b>Compliance</b>	CE, RoHS, FCC
<b>Weight</b>	0.3 lbs. (0.14 kg)
<b>Dimensions (L x W x H)</b>	3.75" x 1.63" x 0.94" (95.3mm x 41.4mm x 23.9mm)

What's in the box:



## DMXcat Accessories

PART NUMBER	DESCRIPTION
6005	XLR5M to RJ45 Adapter
6006	XLR5M to XLR3F Adapter
6007	XLR5M to XLR5M Turnaround
6008	XLR5M to XLR3M Turnaround
6009	DMXcat™ Belt Pouch
6010	USB to Micro USB cable, 6"



Specifications subject to change

800.230.9497 or 201.549.1160

# QolorFLEX® LED Tape



City Theatrical's QolorFLEX brand of LED Lighting is recognized for its superior quality, versatility, and variety. Created specifically for lighting professionals working in theatrical, television and film, and architectural applications, our goal was to produce a premium product line offering designers a multitude of configurations that could be incorporated into their projects easily. Backed by City Theatrical's superior technical expertise and support, QolorFLEX LED Tape is now used on hundreds of productions and in environments across the globe.

In addition to the original QolorFLEX LED Tape, the brand now includes a wide array of wired and wireless dimmers, our plug and play QolorPIX® Pixel Controlled LED Tape system, and QolorFLEX NuNeon linear lighting and accessories – making it the professional's brand of choice for distinctive, dependable LED lighting products.

**Sample Note:**

To order 18" (45cm) samples of QolorFLEX LED Tape, change the Part Number length specifier to "0".

Example:  
5050-12-NW-60-5-20-1

↑  
Length (m)

## QolorFLEX LED Tape Specifications



NAME	VOLTAGE	USE	BACKING COLOR	COLOR TEMP	LED SIZE	LEDs/M	LENGTH	PART NUMBER
Cool White	12	Indoor	White	6500°K	5050	60	5m	5050-12-CW-60-5-20-1
Cool White	12	Indoor	White	6500°K	5050	30	5m	5050-12-CW-30-5-20-1
Cool White	12	Indoor	White	6500°K	3528	60	5m	3528-12-CW-60-5-20-1
Cool White	12	Indoor	White	6500°K	3528	30	5m	3528-12-CW-30-5-20-1
Natural White	12	Indoor	White	4100°K	5050	60	5m	5050-12-NW-60-5-20-1
Natural White	12	Indoor	White	4100°K	5050	30	5m	5050-12-NW-30-5-20-1
Natural White	12	Indoor	White	4100°K	3528	60	5m	3528-12-NW-60-5-20-1
Natural White	12	Indoor	White	4100°K	3528	30	5m	3528-12-NW-30-5-20-1
Warm White	12	Indoor	White	2700°K	5050	60	5m	5050-12-WW-60-5-20-1
Warm White	12	Indoor	White	2700°K	5050	30	5m	5050-12-WW-30-5-20-1
Warm White	12	Indoor	White	2700°K	3528	60	5m	3528-12-WW-60-5-20-1
Warm White	12	Indoor	White	2700°K	3528	30	5m	3528-12-WW-30-5-20-1
RGB	12	Indoor	White	N/A	5050	60	5m	5050-12-RGB-60-5-20-1
RGB + Amber	12	Indoor	White	N/A	5050	60	5m	5050-12-RGBA-60-5-20-1



# QolorFLEX LED Tape Specifications (Continued)

NAME	VOLTAGE	USE	BACKING COLOR	COLOR TEMP	LED SIZE	LEDs/M	LENGTH	PART NUMBER
RGB + Cool White	12	Indoor	White	6500°K	5050	60	5m	5050-12-RGBCW-60-5-20-1
RGB + Natural White	12	Indoor	White	4100°K	5050	60	5m	5050-12-RGBNW-60-5-20-1
RGB + Warm White	12	Indoor	White	2700°K	5050	60	5m	5050-12-RGBWW-60-5-20-1
RGB + Indigo	12	Indoor	White	N/A	5050	60	5m	5050-12-RGBI-60-5-20-1
Cool White	12	Outdoor	White	6500°K	5050	60	5m	5050-12-CW-60-5-67-1
Natural White	12	Outdoor	White	4100°K	5050	60	5m	5050-12-NW-60-5-67-1
Warm White	12	Outdoor	White	2700°K	5050	60	5m	5050-12-WW-60-5-67-1
RGB	12	Outdoor	White	N/A	5050	60	5m	5050-12-RGB-60-5-67-1
RGB + Amber	12	Outdoor	White	N/A	5050	60	5m	5050-12-RGBA-60-5-67-1

## 24V LED Tape:

<b>NEW</b>	HiQ 3200°K	24	Indoor	White	3200°K	2835	120	5m	2835-24-H3200-120-5-20-1
<b>NEW</b>	HiQ 6000°K	24	Indoor	White	6000°K	2835	120	5m	2835-24-H6000-120-5-20-1
<b>NEW</b>	HiQ 2700-6500°K	24	Indoor	White	2700°K, 6500°K	3527	120	5m	3527-24-H27006500-120-5-20-1
<b>NEW</b>	UV	24	Indoor	White	N/A	2835	60	5m	835-24-UV395-60-5-20-1
	Cool White	24	Indoor	White	6500°K	5050	60	5m	5050-24-CW-60-5-20-1
	Natural White	24	Indoor	White	4100°K	5050	60	5m	5050-24-NW-60-5-20-1
	Warm White	24	Indoor	White	2700°K	5050	60	5m	5050-24-WW-60-5-20-1
	RGB	24	Indoor	White	N/A	5050	60	5m	5050-24-RGB-60-5-20-1
	RGB + Cool White	24	Indoor	White	N/A	5050	60	5m	5050-24-RGBCW-60-5-20-1
	Adjustable White	24	Indoor	White	2700°K - 6500°K	3528	120	5m	3528-24-WWCW-120-5-20-1
	Cool White	24	Indoor	White	6500°K	3528	60	5m	3528-24-CW-120-5-20-1
	Warm White	24	Indoor	White	2700°K	3528	60	5m	3528-24-WW-120-5-20-1
	Quad Chip RGB + Amber	24	Indoor	White	N/A	5050	60	5m	5050-24-Q-RGBA-60-5-20-1
<b>NEW</b>	Quad Chip RGB + Cool White	24	Indoor	White	6500°K	5050	60	5m	5050-24-Q-RGBCW-60-5-20-1
	Quad Chip RGB + Indigo	24	Indoor	White	N/A	5050	60	5m	5050-24-Q-RGBI-60-5-20-1
	Quad Chip RGB + Warm White	24	Indoor	White	2700°K	5050	60	5m	5050-24-Q-RGBWW-60-5-20-1
	5-in-1 RGB + Amber + CW	24	Indoor	White	N/A	5050	60	5m	5050-24-RGBACW-60-5-20-1
<b>NEW</b>	5-in-1 HiQ High CRI	24	Indoor	White	N/A	5050	60	5m	5050-24-RGBH27006500-60-5-20-1
	Cool White	24	Outdoor	White	6500°K	5050	60	5m	5050-24-CW-60-5-67-1
	Natural White	24	Outdoor	White	4100°K	5050	60	5m	5050-24-NW-60-5-67-1
	Warm White	24	Outdoor	White	2700°K	5050	60	5m	5050-24-WW-60-5-67-1
	Adjustable White	24	Outdoor	White	2700°K - 6500°K	3528	120	5m	3528-24-WWCW-120-5-67-1
	RGB	24	Outdoor	White	N/A	5050	60	5m	5050-24-RGB-60-5-67-1

# QolorFLEX® 5-in-1 LED Tape

**QolorFLEX® 5-in-1** | HiQ  
PROFESSIONAL LED LIGHTING

NEW

RGBACW:	5050-24-RGBACW-60-5-20-1
HiQ High CRI:	5050-24-RGBH27006500-60-5-20-1



**QolorFLEX 5-in-1 LED Tapes** are interior grade 5-in-1 24V LED Tapes with high output brightness that provide lighting professionals with ultimate five-color control, with their ability to create a wide spectrum of colors when used with a DMX color control system. Each tape comes with wiring leads on both ends and durable 3M adhesive backing. These LED tapes are available in full five meter reels and sample strips. New **QolorFLEX 5-in-1 HiQ High CRI LED Tape** (P/N 5050-24-RGBH27006500-60-5-20-1) has a Color Rendering Index (CRI) of 95 and is 25% brighter than other 5-in-1 LED tapes, for exceptional on-camera color rendition and the ability to match the light sources already being used on set for film and video projects.

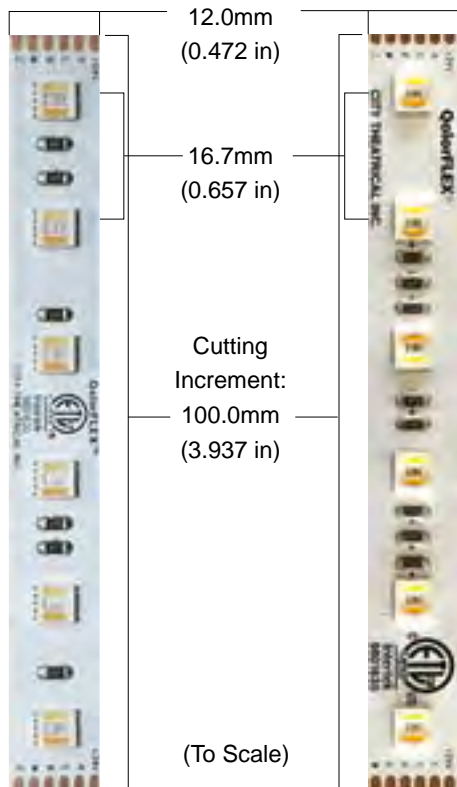

HiQ High CRI

RGB+A+CW

## SPECIFICATIONS:

### Physical

Length	5m	(16.404 ft)
Width	12mm	(0.472 in)
Cutting Increment	100mm	(3.937 in)
LED Spacing	16.7mm	(0.657 in)
Backing Color	White	
Connector Type	200mm long (7.874 in) flat cable on both ends, stripped 10mm and tinned	

### Output & Electrical (All 5-in-1 LED Tapes)

Beam Angle	120°
Operating Voltage	24VDC
Current	2.5 A
Density	60 LEDs/m
LED Chip Size	5050



### Output - HiQ High CRI only NEW

Color(s)	RGB+WW+CW
Color Temperature	2700 K, 6500 K
Wavelength	622/522/468 nm
Brightness	960 lumens/m
CRI	>95
Power Consumption	72 w/5m (4.39 w/ft)

### Output - RGBACW only

Color(s)	RGB+A+CW
Color Temperature	6500K ± 500K
Wavelength	622/518/468/588
Brightness	700 lumens/m
CRI	≥80
Power Consumption	60 w/5m (3.66 w/ft)

### Product Information

Use Environment	Indoor
Dimmable	Fully Dimmable
Average Life	50,000 hours
Warranty	Two years
IP Rating	IP20
Compliance	ETL, CE, RoHS   



# QolorFLEX® HiQ High CRI LED Tape

3200K:	2835-24-H3200-120-5-20-1
6000K:	2835-24-H6000-120-5-20-1
2700-6500K:	3527-24-H27006500-120-5-20-1

**QolorFLEX® HiQ**  
PROFESSIONAL LED LIGHT TAPE

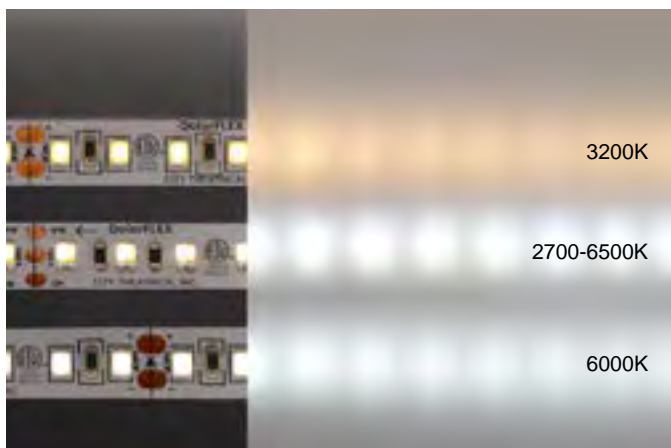

**QolorFLEX HiQ High CRI LED Tapes** were designed to have a Color Rendering Index (CRI) of 95+, making them an ideal high CRI LED tape for the needs of the film industry. **QolorFLEX HiQ High CRI LED Tape** offers exceptional on-camera color rendition and allows lighting professionals to match the light sources already being used on their set. It is available in three color temperatures: **3200K**, **6000K**, and **2700-6500K**. Like all 40+ types of QolorFLEX LED Tape, **QolorFLEX HiQ High CRI LED Tape** is sold in 5m reels and includes six-inch long pigtails on both ends for easy connections to QolorFLEX Dimmers for flicker-free dimming.

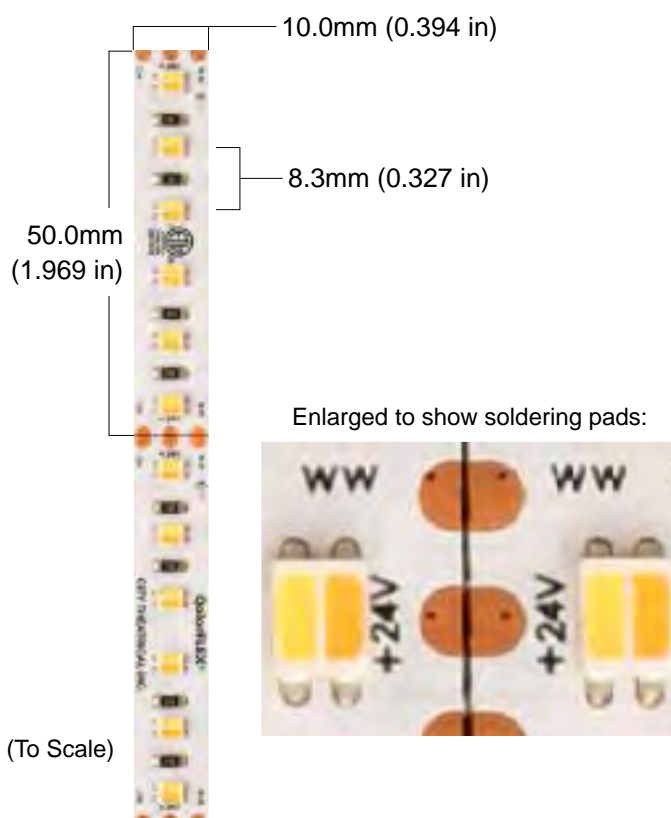





## SPECIFICATIONS:

Physical		
Length	5m	(16.404 ft)
Width	10mm	(0.394 in)
Cutting Increment	50mm	(1.969 in)
LED Spacing	8.3mm	(0.327 in)
Backing Color	White	
Connector Type	200mm long (7.874 in) flat cable on both ends, stripped 10mm and tinned	
Output		
3200K Color/Color Temp.	Warm White; 3200K ± 200K	
6000K Color/Color Temp.	Cool White; 6000K ± 200K	
2700-6500K Color/Color Temperature	Warm White +Cool White; 2700K±150K, 6500K±500K	
Beam Angle	120°	
Brightness	1200 lumens/m	
Color Rendering Index (CRI)	≥ 95	
Electrical (All HiQ High CRI LED Tapes)		
Operating Voltage	24VDC	
Density	120 LEDs/m	
Electrical - 3200K or 6000K only		
Current	2600 mA/5m	
Power Consumption	63 w/5m (3.8 w/ft)	
LED Chip Size	2835	
Electrical - 2700-6500K only		
Current	3200 mA/5m	
Power Consumption	77w/5m (4.69w/ft)	
LED Chip Size	3527	
Product Information		
Use Environment	Indoor	
Dimmable	Fully Dimmable	
Average Life	50,000 hours	
Warranty	Two years	
IP Rating	IP20	
Compliance	ETL, CE, RoHS	

800.230.9497 or 201.549.1160

# QolorFLEX LED Tape Accessories

## Ribbon Cables:

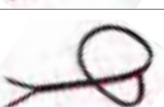







PART NUMBER	NAME		USES
6607	Ribbon Cable, Six Conductor, 18 GA		Used with terminal block connectors to make extension cables when connecting five color LED tape to dimmers. Sold by the foot.
6600	Ribbon Cable, Five Conductor, 18 GA		Used with terminal block connectors to make extension cables when connecting four color LED tape to dimmers. Sold by the foot.
<b>NEW</b> 6600-20	Ribbon Cable, Five Conductor, 20 GA		Used with terminal block connectors to make extension cables when connecting four color LED tape to dimmers, in 20 gauge (slightly thinner than 18 gauge ribbon cable P/N 6600). Sold by the foot.
6608	Ribbon Cable, Four Conductor, 18 GA		Used with terminal block connectors to make extension cables when connecting three color LED tape to dimmers. Sold by the foot.
<b>NEW</b> 6606	Ribbon Cable, Three Conductor, 18 GA		Used with terminal block connectors to make extension cables when connecting two color LED tape to dimmers. Sold by the foot.
<b>NEW</b> 6605	Ribbon Cable, Two Conductor, 18 GA		Used with terminal block connectors to make extension cables when connecting single color LED tape to dimmers. Sold by the foot.

## Connectors:

PART NUMBER	NAME		USES
<b>NEW</b> 6612	Terminal Block Connector, Six Pin, Male		Mating extension multi conductor cable assemblies.
<b>NEW</b> 6613	Terminal Block Connector, Six Pin, Female		Mating output terminal block connector for QolorFLEX Connect 10.
6610	Terminal Block Connector, Five Pin, Male		Mating extension multi conductor cable assemblies.
6611	Terminal Block Connector, Five Pin, Female		Mating output terminal block connector for cable assemblies.
<b>NEW</b> 5673	Terminal Block Connector, Four Pin Male		Mating extension multi conductor cable assemblies.
<b>NEW</b> 5674	Terminal Block Connector, Four Pin Female		Mating output terminal block connector for cable assemblies.
<b>NEW</b> 5671	Terminal Block Connector, Three Pin Male		Mating extension multi conductor cable assemblies.
<b>NEW</b> 5672	Terminal Block Connector, Three Pin Female		Mating output terminal block connector for cable assemblies.
<b>NEW</b> 5657	Terminal Block Connector, 2-Pin Male		Mating extension terminal block connector for cable assemblies.
<b>NEW</b> 5658	Terminal Block Connector, 2-Pin Female		Mating output terminal block connector for cable assemblies.
6615	Female barrel to screw terminal connector		For making Two Conductor plug-in cable assemblies.
6616	Male barrel to screw terminal connector		For making Two Conductor plug-in cable assemblies.

# QolorFLEX LED Tape Accessories (Continued)

## Extrusions and Diffusers, End Caps, Tape, and Tape Clips:

PART NUMBER	NAME	USES
<b>NEW</b> 6693	45-Degree Extrusion 	Aluminum Extrusion, 45-Degree, 2m for 45-Degree LED Tape installations.
<b>NEW</b> 6694	Diffuser for 45-Degree Extrusion 	Diffuser for 45-Degree Extrusion, 2m.
6695	Low Profile Extrusion 	Diffuser for Low Profile Extrusion, 2m.
6690	Diffuser for Low Profile Extrusion 	Aluminum Extrusion, Low Profile, 2m.
<b>NEW</b> 6690-1	End Cap for 6690 Extrusion 	Ends the 6690 Aluminum Extrusion. Sold in packs of 10.
<b>NEW</b> 6690-2	End Cap with hole for 6690 Extrusion 	Ends the 6690 Aluminum Extrusion, includes a hole. Sold in packs of 10.
6680 6682 6684 6686	Waterproof end caps for outdoor tapes: 9mm w/ 2 holes 8mm (no holes) 12mm w/ 4 holes 12mm (no holes) 	For making waterproof connections and terminating ends of outdoor rated LED tape. Sold in packs of 10.
6625	3M VHB Double Sided Tape Roll, 72 yards 	The tape we recommend for long-term reliability for stick on surfaces.
6630	Outdoor Tape Clips and Screws 	For securing Outdoor LED tape. Sold in packs of 12.

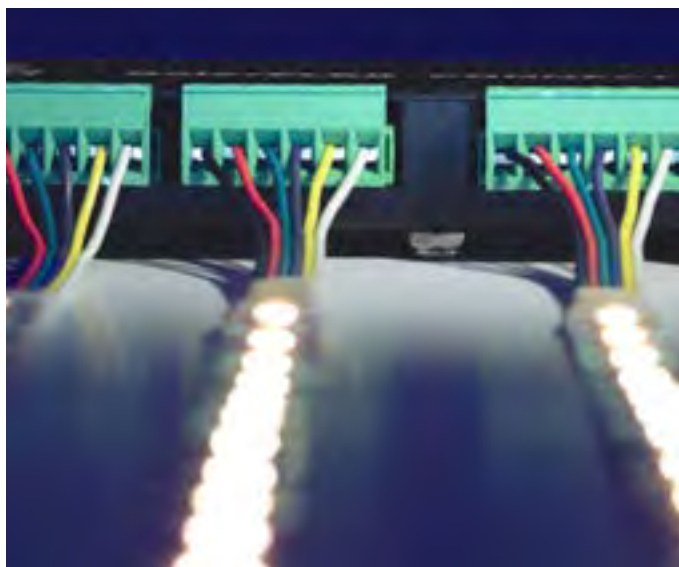
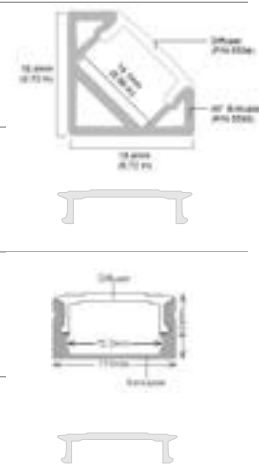

## QolorFLEX Connect 10

Part Number: 5748



QolorFLEX Connect 10 is a practical and time saving solution for managing the multiple wire runs and numerous connections needed for large scale installations of LED tape in entertainment and architectural projects.

Developed to complement QolorFLEX 5-in-1 LED Tape, QolorFLEX Connect 10 is a “plug-in box” that can connect up to nine runs of five, four, three, dual, or single color LED tape to a low voltage low dimmer. Each QolorFLEX Connect 10 uses 10 six position detachable Phoenix terminal block connectors to achieve a quick and well-ordered installation. QolorFLEX Connect 10 is constructed with a Nema 4 IP 20 steel enclosure, and offers a maximum current per device of 40A and maximum load per terminal of 20A.



**QolorFLEX NuNeon®**  
NEON EFFECT LED LIGHTING

QolorFLEX NuNeon in Macy's Herald Square "Believe In Wonder" Holiday Windows in NYC | Designed by Standard Transmission

QolorFLEX NuNeon is an incredibly flexible and bright sealed LED linear lighting product that can be used to replace traditional neon lighting in entertainment and architectural projects. It was carefully developed to provide lighting and scenic designers with a way to add bold and bright accents to their designs with the benefits of minimal maintenance, durability, and low power consumption as compared to glass blown neon.

Available in seven individual colors plus adjustable RGB, QolorFLEX NuNeon is IP67 rated for use indoors or outdoors and is ETL listed. Single colors are sold in 10m lengths, and RGB is available in 5m lengths.

QolorFLEX NuNeon is fully compatible with QolorFLEX Dimmers, Power Supplies, and the many other accessories for wiring and mounting that are available.

### **Distinct advantages of QolorFLEX NuNeon over competitive "Neon Replacement" products include:**

**Bright, Even Light.** The LED tape within the silicone casing uses smaller high output 2835 chip diodes/emitters, which are closely spaced together (140 LEDs/m) to provide a more even light output with no hot spots.

**UV Resistance.** QolorFLEX NuNeon casing is made from a unique co-extruded mix of silicone polymers that provide a highly effective reflective support and translucent diffuser with both superior UV resistance and increased flexibility as compared to other PVC extruded products.

**Incredibly Flexible.** The tape is positioned at 45 degrees to the vertical axis, allowing a high degree of flexibility (Minimum Bend Radius is 1/2 inch) and excellent light transmission.

**Easy to Install.** The LED tape inside QolorFLEX NuNeon's silicone casing is not molded in place, but rather inserted after extruding. This makes cutting and soldering much easier, as no extrusion material has to be scraped away from the contacts on the tape.

**Easy to Fit Difficult Spaces.** QolorFLEX NuNeon is only 9mm wide by 14mm high (in its cross section), allowing it to be installed in many locations where larger scaled products just won't fit.

**Less Waste.** The cutting increment for QolorFLEX NuNeon is just under two inches, allowing for greater control during installation with less waste.

**NEW Available in High CRI for Film & Video projects.** QolorFLEX NuNeon, Tunable White HiQ High CRI (P/N N914-H27006500-5), shown left below, offers exceptional on-camera color rendition with a color rendering index greater than 94, allowing lighting professionals to meet the needs of high quality film and video lighting.





## QolorFLEX NuNeon Specifications

PART NUMBER	NAME	VOLTAGE	COLOR TEMP	WAVELENGTH	POWER CONSUMPTION	LENGTH
<b>NEW</b> N914-H27006500-5	QolorFLEX NuNeon, Tunable White HiQ High CRI	24	2700°K, 6500°K	N/A	70 w/5m (1 reel)	5m
N914-CW-10	QolorFLEX NuNeon, Cool White	24	6500°K	N/A	72w/10m (1 reel)	10m
N914-NW-10	QolorFLEX NuNeon, Natural White	24	4000°K	N/A	72w/10m (1 reel)	10m
N914-WW-10	QolorFLEX NuNeon, Warm White	24	2700°K	N/A	72w/10m (1 reel)	10m
N914-A-10	QolorFLEX NuNeon, Amber	24	N/A	588 nm	72w/10m (1 reel)	10m
N914-B-10	QolorFLEX NuNeon, Blue	24	N/A	468 nm	72w/10m (1 reel)	10m
N914-G-10	QolorFLEX NuNeon, Green	24	N/A	518 nm	72w/10m (1 reel)	10m
N914-R-10	QolorFLEX NuNeon, Red	24	N/A	622 nm	72w/10m (1 reel)	10m
N914-RGB-5	QolorFLEX NuNeon, RGB	24	N/A	622/518/468 nm	48 w/5m (1 reel)	5m

## QolorFLEX NuNeon Accessories

PART NUMBER	NAME
N914-01	QolorFLEX NuNeon End Cap with Strain Relief, Pack of 10 
N914-02	QolorFLEX NuNeon End Cap, Pack of 10 
N914-03	QolorFLEX NuNeon Lead Wire, Two Wire, 40cm 
N914-03-100	QolorFLEX NuNeon Lead Wire, Two Wire, 40cm (not pictured)
N914-04	QolorFLEX NuNeon Lead Wire, Four Wire, 40cm 
N914-04-100	QolorFLEX NuNeon Lead Wire, Four Wire, 40cm (not pictured)

PART NUMBER	NAME
N914-05	QolorFLEX NuNeon Aluminum Extrusion, 2m 
N914-07	QolorFLEX NuNeon Aluminum Extrusion Mounting Clip, Pack of 10 
N914-09	QolorFLEX NuNeon Plastic Mounting Clip, 30mm, Pack of 10 
NU1040	QolorFLEX NuNeon Silicone, White 
NU1034	QolorFLEX NuNeon Heat Shrink Tubing, Clear, 2 feet (0.6m) 



QolorPIX on *The Tonight Show Starring Jimmy Fallon*  
Worn by host Jimmy Fallon and guest Jake Gyllenhaal  
during "Brainstorm" segment

Designed by Kelly Hanson  
Engineered and Constructed by Rachel Navarro  
Photo by Andrew Lipovsky/NBCU Photo Bank via Getty Images

**QolorPIX Is Pixel Control Made Simple.**

While many products on the market offer control of addressable LED tape and fixtures, the process of set up and operation can be challenging. Each QolorPIX Tape Controller is pre-configured with personality profiles that can be combined and adjusted quickly and easily to produce thousands of effects using QolorPIX Pixel Controlled LED Tape, including chases, fades, scrolls, bursts, and more.



**QolorPIX Pixel Controlled LED Tape**

Part Number: Q5050-5-RGB-48-5-67-2

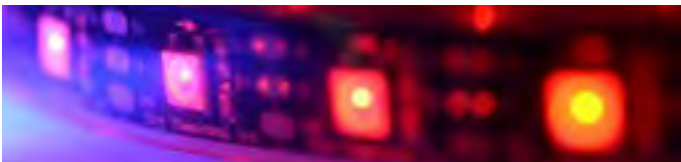

QolorPIX Pixel Controlled LED Tape is designed for the most demanding professional applications, with 48 individually controlled LED lights per meter. Each reel of tape includes a soldered-on four-pin XLR connector on one end, creating a plug and play connection to the QolorPIX Tape Controller. QolorPIX Pixel Controlled LED Tape runs on low voltage (5VDC) and is sold in five meter reels, with a maximum cable connection length (between controller and tape) of 10 meters. The tape is encased in clear rectangular silicone, making it water resistant (IP 67 rated) for indoor or outdoor use.

**SPECIFICATIONS**

<b>Part Number</b>	Q5050-5-RGB-48-5-67-2
<b>LEDs per meter</b>	48
<b>Voltage</b>	5VDC
<b>Watts/meter (max)</b>	14.4W
<b>Viewing angle</b>	120°
<b>PCB color (backing)</b>	Black
<b>IP Rating</b>	67
<b>Coating</b>	Clear Silicone
<b>Connection</b>	4-Pin XLRM soldered to 6" pigtail
<b>Cutting increment</b>	0.827" (21mm)
<b>Height</b>	0.188" (4.8mm)
<b>Width</b>	0.563" (14.3mm)
<b>Length</b>	16.4' (5m)

# QolorPIX Tape Controller, Eight Output

Part Number: 5850



The QolorPIX Tape Controller offers eight ports, each accommodating five meters of pixel tape. It has a user-friendly control interface that allows the user to change mode, pixel length, dimmer, personality start address, and direction. It features an integrated power supply, a test function, and flicker finder for easy troubleshooting. It also offers wireless DMX control using Multiverse wireless DMX/RDM technology.



## SPECIFICATIONS

<b>Part Number</b>	5850
<b>Number of outputs</b>	8
<b>Max LEDs per output</b>	240
<b>Voltage</b>	85-264 VAC
<b>Watts (total output)</b>	600W
<b>Max cable distance to LED strip</b>	10m (32.8 feet)
<b>Output connectors</b>	4-Pin XLR
<b>Input power connection</b>	Powercon
<b>DMX connections:</b>	5-Pin XLR
<b>Compliance</b>	ETL, CE, RoHS, FCC
<b>Construction</b>	NEMA 1 IP 20 steel enclosure

## QolorPIX Accessories

PART NUMBER	NAME
5840	Power Cord, N5-15P to powerCON TRUE1 12 AWG 8'
5870	QolorPIX Rack Mount/ Pipe Mount Ears
5729	2dBi Omni , Indoor 2.3"
5891	Four Pin XLRM with Three Conductor, 6" Tail

PART NUMBER	NAME
6670	Mounting Clip Kit with Screws (for one roll of QolorPIX Pixel Controlled LED Tape)
6691	QolorPIX Aluminum Extrusion, 2m 21mm W x 9mm H <i>(Image represents both 6691 and 6696)</i>
6696	QolorPIX Diffuser for 6691 Extrusion, 2m
6692	QolorPIX Aluminum Extrusion, 2m 21mm W x 14mm H <i>(Image represents both 6692 and 6697)</i>
6697	QolorPIX Diffuser for 6692 Extrusion, 2m

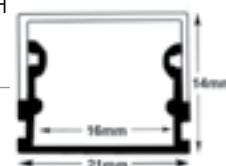
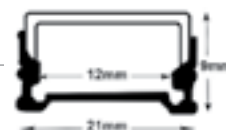

# QolorFLEX LED Dimmers



QolorFLEX LED Dimmers pair perfectly with QolorFLEX LED Tape. All QolorFLEX Dimmers (seven wired and four wireless) are RDM capable, deliver ultra smooth, flicker-free PWM dimming, and are available in two, three, four, five, six, and twenty four channel models.

Our QolorFLEX 5x8A Dimmer, as an example, pairs perfectly with QolorFLEX 5-in-1 LED Tape. Our QolorFLEX

4x10A Dimmer with integrated power supply is the workhorse of theatrical productions and touring events alike, featuring four dimming modes and four variable smoothing rates.

Several mounting styles are available to work with different installation requirements. QolorFLEX accessories, like wire, connectors, extrusions, and power supplies are available.

## QolorFLEX 24x3A Dimmer

*Part Number: 5810*

The QolorFLEX 24x3A Dimmer features twenty four channels of control and is suited for larger installations like retail spaces, or architectural illumination. It is compatible with 12V and 24V single color and multi-color LED tapes. It can be operated with a standard DMX color controller, or as a stand alone device using one of its pre-programmed color changing modes. The QolorFLEX 24x3A Dimmer is rated at 3A per channel maximum output. The unit requires a separate power supply providing input voltage of 12 or 24VDC to match the LED tape you are using. The maximum current load per channel is 3A with a maximum device output of 72A.



## QolorFLEX 5x8A Dimmer

*Part Number: 5809*

The QolorFLEX 5x8A Dimmer can control a full 40A of LED tape spread over five channels of 8A each. This allows the control of 5-in-1 LED tape and unique combinations, such as RGB tape (three channels) and bi-color tape (two channels), or RGBX tape (four channels) and a single color tape (one channel) together in one unit. QolorFLEX 5x8A Dimmers use constant voltage technology to ensure consistent full range dimming, which is especially important at low end light levels. An easy to read onboard display and four button user interface allows selection of stand alone mode or setting DMX addresses, setting quantity of DMX channels, selecting 8 or 16 bit output resolution, setting PWM frequency (500Hz to 30KHz), setting output dimming curve values for matching the dimming curves of other dimmers in use, and setting the device's operating profile. QolorFLEX 5x8A Dimmers are also RDM capable. The unit requires a separate power supply providing input voltage of 12 or 24VDC to match the LED tape you are using. The maximum current load per channel is 8A with a maximum device output of 40A.





## QolorFLEX 4x5A Dimmer

*Part Number: 5821*

The QolorFLEX 4x5A Dimmer can control a full 20A of LED tape spread over four channels of 5A each. It uses constant voltage technology which ensures consistent full range dimming that is especially important at low end light levels. The unit is easily surface mounted and has spring contact terminal blocks for all electrical and data connections. An easy to read onboard display and four button user interface allows selection of stand alone mode or setting DMX addresses, setting quantity of DMX channels, selecting 8 or 16 bit output resolution, setting PWM frequency (500Hz to 30KHz), setting output dimming curve values for matching the dimming curves of other dimmers in use, and setting the device's operating profile. The QolorFLEX 4x5A Dimmer is also RDM capable. The unit requires a separate power supply providing input voltage of 12 or 24VDC to match the LED tape you are using. The maximum current load per channel is 5A with a maximum device output of 20A.



## QolorFLEX 4x5A DINrail Dimmer

*Part Number: 5825*

## QolorFLEX 4x5A DINrail RJ45 Dimmer

*Part Number: 5823*

The QolorFLEX 4x5A DINrail Dimmers can control a full 20A of LED tape spread over four channels of 5A each. They use constant voltage technology which ensures consistent full range dimming that is especially important at low end light levels. Both units mount to a standard hat section DIN rail.

Model 5823 features two RJ45 connectors for DMX communication plus spring contact terminals for power and output connections. Model 5825 has spring contact terminals for all connections.

Both feature easy to read onboard displays and four button user interface for setting DMX addresses, setting quantity of DMX channels, selecting 8 or 16 bit output resolution, setting PWM frequency (500Hz to 30KHz), setting output dimming curve values for matching the dimming curves of other dimmers in use, and setting the devices operating profile. Both units are RDM capable. Each unit requires a separate power supply providing input voltage of 12 or 24VDC to match the LED tape you are using. The maximum current load per channel is 5A with a maximum device output of 20A.



## QolorFLEX 3x10A Dimmer

*Part Number: 5620*

The QolorFLEX 3x10A Dimmer is our most versatile and feature rich dimmer. The total output capacity of the dimmer is 30A and any channel is capable of carrying a full 30A. The large backlit LCD display and five button control makes the QolorFLEX 3x10A Dimmer the industry leader in ease of set-up and operation. It accepts wired data from any controller/console with DMX output, can be paired with one of our wireless transmitting/receiving systems, and has stand alone dimmer settings to allow use without a lighting controller/console. The QolorFLEX 3x10A Dimmer's additional features include: four selectable dimming curves/modes, variable smoothing rates, film/video modes, starting DMX address, and it is fully RDM enabled. 9-24VDC 30A max input. 30A max output per device.



## QolorFLEX Architectural LED PS/Driver Series

*Part Number: 5758*

QolorFLEX Architectural LED PS/Drivers provide a powerful and affordable way to power and control LED tape or other

LEDs in a permanent NEMA enclosure. They offer user selectable PWM dimming that is guaranteed not to flicker on camera which can be critical for those meeting areas where video or film image recording is in use for teleconferencing or any newsworthy event.

The drivers are ETL listed and CE certified, and feature DMX and 0-10V input control, an Integrated Power Supply AC to DC, and Four Class 2 rated dimmable circuits.

The drivers come in a rugged compact NEMA 1 steel enclosure with holes for wall mounting, electrical knockouts, and screw terminal connections. All models are made to order, with other configurations available.



# QolorFLEX 2x2.5A Multiverse Dimmer

P/N	Frequency	Universes
5916	2.4GHz	1
5917	900MHz	1

Designed for Props,  
Costumes, Wands,  
and Candles



**QolorFLEX® 2x2.5A Multiverse® Dimmers are small, constant voltage, two-output dimmers designed to be mounted in small spaces such as props, costumes, wands, and candles.**

These dimmers can be controlled wirelessly using City Theatrical's Multiverse or SHoW DMX Neo wireless DMX/RDM technology, or with wired DMX. Each dimmer provides 20-bit PWM resolution and four DMX personality options (two variations of 8-bit and 16-bit control) for extremely smooth dimming at the low end of the dimming curve. Configuration is performed using RDM, such as with a City Theatrical DMXcat®, or with City Theatrical's USB Configuration program for PC or Mac.

A plastic case is included with each QolorFLEX 2x2.5A Multiverse Dimmer to allow easy mounting to scenery while enabling removal of the dimmer from the case for wiring and configuration. These dimmers are designed and built in the USA by City Theatrical.

## Key Features

- Ideal for props and costumes with a low profile
- Supports ANSI E1.11 DMX512-A
- Compatible with all Multiverse and SHoW DMX transmitters
- Low profile latch connections for power, dimmer outputs, and DMX out
- Output port test buttons
- Configuration set via RDM or with City Theatrical's USB Configuration Program for PC or Mac.
- Built-in short circuit, reverse polarity, and over temperature protection



# QolorFLEX 5x2.5A Multiverse Dimmer

P/N	Frequency	Universes
5942	900MHz/2.4GHz	1
5943	2.4GHz	1

Constant Voltage,  
Five-output, Wireless  
DMX/RDM dimming



**QolorFLEX® 5x2.5A Multiverse® Dimmers are constant voltage, five-output dimmers that can be controlled wirelessly using City Theatrical's Multiverse wireless DMX/RDM technology, or legacy SHoW DMX Neo wireless DMX/RDM, or with wired DMX.**

Each dimmer provides 20-bit PWM resolution and six DMX personality options (including: 8-bit (5ch), 16-bit (10ch), 8-bit Tunable White Single (2ch), 16-bit Tunable White Single (4ch), 8-bit Tunable White (4ch), and 16-bit Tunable White (8ch)) for extremely smooth dimming at the low end of the dimming curve. These dimmers use detachable input and output connectors to make wiring easy. Configuration is performed using RDM, such as with a City Theatrical DMXcat®, or with City Theatrical's USB Configuration program for PC/Mac. A mounting bracket is included with each dimmer to allow easy mounting to scenery. These dimmers are designed and built in the USA by City Theatrical, and pair perfectly with QolorFLEX 5-in-1 LED Tape for ideal use in props and costumes, or for areas where space is a concern.

## Key Features

- Wireless or wired DMX input
- Wired DMX output
- Mounting bracket included
- Compatible with all Multiverse and SHoW DMX Neo SHoW IDs
- User selectable choice of 2.4GHz or 900MHz radio (P/N 5942 only)
- DMX termination selector switch
- Per channel level indicator lights, PWM frequency, response time, curve selections, bump buttons with disable function, offsets to balance the point at which each dimmer first turns on (important for perfect low end balance)



## Accessories for 5942/5943 Dimmers:

PART NUMBER	NAME	
5950	XLR5M and XLR5F to Three Position Phoenix Connector, Female, 6"	
5984	Antenna, Omni, 900MHz/2.4GHz, 1.8dBi/3.8dBi Dual Band Stubby	
5954	Mounting Plate	

PART NUMBER	NAME	
5951	Phoenix Connector, Six Position, Female	
5952	Phoenix Connector, Three Position, Female	
5668	Phoenix Connector, Two Position, Female	

800.230.9497 or 201.549.1160

# QolorFLEX LED Dimmer Specifications





Name	<b>QolorFLEX 2x2.5A Multiverse Dimmer</b>	<b>QolorFLEX 3x10A Dimmer</b>	<b>QolorFLEX 4x5A Dimmer</b>	<b>QolorFLEX 4x5A DINrail RJ45 Dimmer</b>
<b>Part Number</b>	5916 (2.4GHz), 5917 (900MHz)	5620	5821	5823
<b>Output Channels</b>	2	3	Selectable, 1 to 4	4
<b>Input Voltage</b>	6-30VDC	9-24VDC	12 to 36VDC 20A	12~24VDC
<b>Max Output per Channel</b>	0.9A @12V	30A	5A	5A
<b>Max Device Output</b>	1.8A	30A	20A@12V	20A
<b>Size L x W x H</b>	3.187" x 0.7" x 0.5" (81 x 18.8 x 12mm)	6.25" x 5.125" x 2.375" (128.8 x 120.2 x 60.3mm)	2.1" x 6.7" x 1.1" (53.4 x 170 x 28mm)	2.1" x 6.7" x 1.1" (53.4 x 110 x 65mm)
<b>Weight</b>	0.32 oz (9g)	32 oz (0.9 kg)	4.8 oz (0.14 kg)	4 oz (0.11kg)
<b>Power Connections</b>	Spring Terminals	45A Anderson Powerpole	Spring Terminals	Spring Terminals
<b>Output Connections</b>	Spring Terminals	45A Anderson Powerpole	Spring Terminals	Spring Terminals
<b>DMX Connections</b>	Spring Terminals	5 Pin XLR	Spring Terminals	2x RJ45
<b>0-10V Connections</b>	N/A	N/A	N/A	No
<b>User Interface</b>	RDM/USB	5 button with backlit LCD	4 Button, plus alpha/ numeric display	4 button, plus alpha/ numeric display
<b>DMX Address</b>	Yes	Yes	Yes	Yes
<b>Curve Selection</b>	Yes - 3	Yes - 4	Yes - 99	Yes - 99
<b>Film &amp; Video Modes</b>	Yes - 5	Yes - 5	Yes - 18	Yes - 18
<b>DMX Termination</b>	N/A	Yes	No	No
<b>SHoW ID</b>	All Multiverse & Neo	N/A	No	N/A
<b>Bump Buttons</b>	Yes	Yes	No	No
<b>Pilot Lights</b>	Yes	Yes	Yes	Yes
<b>Status Light</b>	Yes	Yes	No	No
<b>Smoothing Settings</b>	Yes - Variable 6	Yes - Variable 6	No	No
<b>Stand Alone Levels</b>	No	Yes	Yes	Yes
<b>RDM</b>	Yes	Yes	Yes	Yes
<b>Compliance</b>	5916: CE, RoHS, FCC, AU, Japan, IC 5917: RoHS, FCC, IC	CE, ETL	CE, RoHS	CE, RoHS

# QolorFLEX LED Dimmer Specifications (Continued)



<b>QolorFLEX 4x5A DINrail Dimmer</b>	<b>QolorFLEX 5x2.5A Multiverse Dimmer</b>	<b>QolorFLEX 5x8A Dimmer</b>	<b>QolorFLEX 24x3A Dimmer</b>	<b>QolorFLEX Architectural LED PS/Driver Series</b>
5825	5942 (900MHz/2.4GHz), 5943 (2.4GHz)	5809	5810	5758
4	5	5	24	4
12~24VDC	5-30VDC	12~24VDC	12~24VDC	100V-277VAC
5A	4A	8A	3A	3.3A
20A	12.5A	40A	72A	10A
2.1" x 4.32" x 2.56" (53.4 x 110 x 65mm)	5.63" x 2.75" x 0.63" (143 x 70 x 16mm)	2.88" x 6.5" x 1.5" (73 x 165 x 38mm)	10.24" x 4.72" x 1.57" (260 x 120 x 40mm)	10.5" x 16.15" x 3.56" (266mm x 410mm x 91mm)
4 oz. (0.11 kg)	2.4 oz (70g)	13.6 oz (0.39 kg)	3 lbs. (1.36kg)	14.5 lbs. (6.58kg)
Spring Terminals	Pluggable connectors	Screw Terminals	Screw Terminals	Hard wire terminals
Spring Terminals	Pluggable connectors	Screw Terminals	Screw Terminals	Hard wire terminals
Spring Terminals	Pluggable connectors	5-Pin XLR, RJ-45, Screw Terminals	5 Pin XLR, RJ-45	RJ-45
No	N/A	No	No	User Selectable Sourcing or Sinking
4 button, plus alpha/ numeric display	RDM/USB	4 button, plus alpha/ numeric display	4 button, plus alpha/ numeric display	DIP Switches, BCD
Yes	Yes	Yes	Yes	Yes
Yes - 99	Yes - 3	Yes - 99	Yes - 99	Yes - 4
Yes - 18	Yes - 5	Yes - 18	Yes - 18	Yes - 5
No	N/A	No	No	Yes
N/A	All Multiverse & Neo	N/A	N/A	Yes
No	Yes	No	No	N/A
Yes	Yes	Yes	Yes	Yes
No	Yes	No	No	Yes
No	Yes - Variable 6	No	No	Yes - 6
Yes	No	Yes	Yes	No
Yes	Yes	Yes	Yes	Yes
CE, RoHS	5942: RoHS, FCC, IC 5943: CE, RoHS, FCC, ACMA, ARIB, IC	CE, ROHS	CE, ROHS	ETL

# QolorFLEX LED Dimmer Accessories

PART NUMBER	NAME
6611	5-Pin Female connector for 5x8A and 24x3A Dimmers 
6621	XLR3M to XLR5F Adaptor 

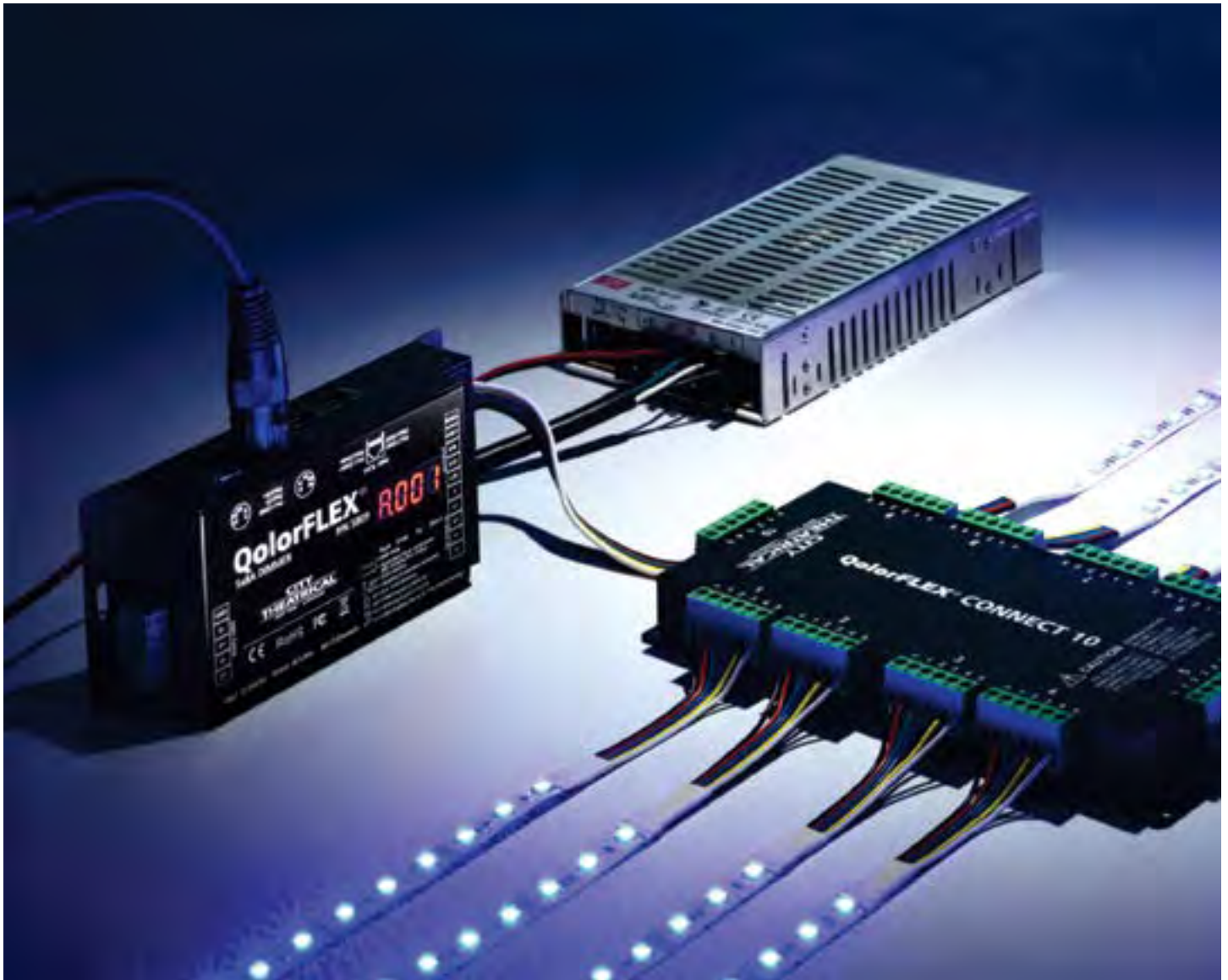

## Integrated Dimming Systems

City Theatrical has designed and built hundreds of custom integrated LED dimming/control systems for industry professionals who demand high performance and dependability. We have installed these systems on sets and stages for dozens of television and theatrical shows around the United States. As designers and manufacturers of high end control components used in LED operation, we understand the challenges and constraints of producing these types of assemblies. We have developed a means of producing integrated dimming systems which are fully tested, use state of the art components, are economically viable, and can be delivered quickly. Contact a sales representative for more information and a pricing estimate.

### EXAMPLE 1

Unit includes: six P/N 5823 QolorFLEX 4x5A DINrail Dimmers offering 24 channels of control, an internally mounted 320W 12VDC fan cooled power supply, six XLR6 output connectors, XLR5 in and thru DMX connectors, and Powercon in and thru connectors for AC input. Unit is ETL listed to UL508A. Overall unit size is 14" x 14" x 2 3/4". Steel enclosure with black powder coat.



*Connector panel*



*Full Cover*



*Cover Removed*

### EXAMPLE 2

Unit includes: five P/N 5821 QolorFLEX 4x5A Dimmers for 20 channel- 4 x 4 color dimming and 4 x 1 color dimming, an externally mounted 120W fanless power supply, phoenix screw terminal output connectors, XLR5 in and thru DMX connectors, and Powercon in and thru connectors for AC input. Unit is ETL listed to UL508A. Overall unit size is 14" x 14" x 2". Steel enclosure with black powder coat.



*Connector panel*



*Full Cover*



*Cover Removed*

### EXAMPLE 3

Unit includes: one P/N 5809 QolorFLEX 5x8A Dimmer for five channels of 8A dimming, 600W fanless power supply w/ Edison cord, five Wago quick connect splicing terminal blocks for output connections. Overall unit size is 16" x 9 1/2" x 2". The 1/8 inch aluminum base plate acts as secondary heat sink.



# LED Power Supplies

City Theatrical uses Mean Well and other fine power supplies to power LED tape. The power supply must be matched in both voltage and wattage to the LED tape project you are specifying, and this is often a difficult and

confusing moment for lighting users. Call us for help in designing and laying out your project. We can talk you through it and help you put your order together, or we can do the whole thing for you.



**AD-24-12**



**RSP-75-12  
RSP-75-24**



**RSP-150-12  
RSP-150-24**



**RSP-320-12  
RSP-320-24**



**RSP-500-12  
RSP-500-24**

## SPECIFICATIONS

Part Number	AD-24-12	RSP-75-12 RSP-75-24	RSP-150-12 RSP-150-24	RSP-320-12 RSP-320-24	RSP-500-12 RSP-500-24
<b>Configuration</b>	Wall	Enclosed	Enclosed	Enclosed	Enclosed
<b>Current, Output</b>	2A	6.3 A / 3.2A	12.5 A / 6.3A	26.7A / 13.4A	41.7A / 21A
<b>Size L x W x H</b>	3.00" x 1.5" x 3.00" (76.2mm x 38mm x 76.2mm)	6.25" x 3.82" x 1.18" (159mm x 97mm x 30mm)	7.83" x 3.89" x 1.18" (199mm x 99mm x 30mm)	8.46" x 4.52" x 1.18" (215mm x 115mm x 30mm)	9.06" x 5.00" x 1.59" (230mm x 127mm x 40.5mm)
<b>Mounting Type</b>	Wall Plug	Panel	Panel	Panel	Panel
<b>Number of Outputs</b>	1	1	1	1	1
<b>Operation</b>	PFC	PFC	PFC	PFC	PFC
<b>Output</b>	12VDC@2A	12VDC@6.3A 24VDC@3.2A	12VDC@12.5A 24VDC@ 6.3A	12VDC@26.7A 24VDC@13.4A	12VDC@41.7A 24VDC@21A
<b>Power, Output</b>	75W	75.6W / 76.8W	150W / 151.2W	320.4W / 321.6W	500.4 W / 504W
<b>Primary Type</b>	AC-DC	AC-DC	AC-DC	AC-DC	AC-DC
<b>Type</b>	Non-Commercial	Commercial	Commercial	Commercial	Commercial
<b>Voltage, Input</b>	100-240 VAC	85-264 VAC	85-264 VAC	88-264 VAC	85-264 VAC
<b>Voltage, Output</b>	12 VDC	12 VDC 24VDC	12 VDC 24VDC	12 VDC 24VDC	12 VDC 24VDC



# Outdoor Rated Fanless LED Power Supplies

The HLG series of power are fanless and perfect for areas where silent operation is critical, such as studios. All are IP 65 - 67 rated for indoor or outdoor use in all weather conditions, and are auto ranging from 90-305 VAC.



**HLG-80H-24A**



**HLG-150H-24A**



**HLG-240H-24A**



**HLG-320H-24A**



**HLG-600H-24A**

## SPECIFICATIONS

Part Number	HLG-80H-24A	HLG-150H-24A	HLG-240H-24A	HLG-320H-24A	HLG-600H-24A
<b>Configuration</b>	Enclosed	Enclosed	Enclosed	Enclosed	Enclosed
<b>Current, Output</b>	3.4A	6.3A	10A	13.34A	25A
<b>Size L x W x H</b>	7.7" x 2.42" x 1.53" (195.6mm x 61.5mm x 38.8mm)	8.98" x 2.68" x 1.53" (228mm x 68mm x 38.8mm)	9.61" x 2.68" x 1.53" (244.2mm x 68mm x 38.8mm)	9.92" x 3.54" x 1.72" (252mm x 90mm x 43.8mm)	11.02" x 5.67" x 1.91" (280mm x 144mm x 48.5mm)
<b>Mounting Type</b>	Panel	Panel	Panel	Panel	Panel
<b>Number of Outputs</b>	1	1	1	1	1
<b>Operation</b>	PFC	PFC	PFC	PFC	PFC
<b>Output</b>	24VDC@3.4A	24VDC@6.3A	24VDC@10A	24VDC@13.34A	24VDC@25A
<b>Power, Output</b>	80W	150W	240W	320W	600W
<b>Primary Type</b>	AC-DC	AC-DC	AC-DC	AC-DC	AC-DC
<b>Type</b>	Commercial	Commercial	Commercial	Commercial	Commercial
<b>Voltage, Input</b>	90-305 VAC	90-305 VAC	90-305 VAC	90-305 VAC	90-305 VAC
<b>Voltage, Output</b>	24VDC	24VDC	24VDC	24VDC	24VDC

# Wireless LED Event Lighting



## Lighting for life's most important moments.

Whether it's a corporate event, a wedding, an anniversary party, or any other of life's most important events, you want to make it special and memorable. City Theatrical's QolorPoint® Wireless LED Uplighter will make your event unforgettable by adding colorful lighting, and will make setup fast and easy.

The QolorPoint Wireless LED Uplighter's great breakthroughs in LED lighting technology allow modern fixtures to change colors, while their low power consumption allows battery operation, and radio control allows users to operate them without wires. This unique combination of technologies has produced the ability to quickly and easily set up beautiful lighting effects with no wires at all, and these factors lend themselves perfectly to

event lighting that is typically set up and used for one day.

City Theatrical has partnered with UK lighting manufacturer Core Lighting to present the world's premier uplighter for event lighting. Core Lighting specializes in designing and manufacturing fully weatherproof battery powered LED uplighters with wireless DMX/RDM control, allowing them to be used with no power or data cables. Extremely bright and colorful, Core's products feature leading edge design, rugged construction, and utilize lightweight but powerful rechargeable lithium ion battery technology. These products are built for professional use, day after day.

To give your clients the experience of a lifetime, choose City Theatrical's QolorPoint Wireless LED Uplighter with onboard Multiverse® wireless DMX/RDM technology. We are creating lighting for life's most important moments.



Cheltenham Town Hall (Anne Marie Randall)



Night to Shine in Milford, CT (Kris Hodge)



The Spheres (Amazon Photo / Jordan Stead)

# QolorPoint® Wireless LED Uplighter

Part Number: 7000



## Sleek. Outdoor Rated. Multiverse wireless DMX/RDM.

Sleek enough for upscale indoor use and IP65 rated for outdoor use, QolorPoint Wireless LED Uplighters can be used to instantly transform any function, from small parties to large corporate events, weddings, entertainment venues, and even for stage lighting. The combination of battery power and wireless DMX control makes them truly portable, enabling extremely fast setup with no cables, thus creating a safer and more attractive environment. The sleek and shiny exterior finish blends into any décor.

QolorPoint Wireless LED Uplighters are known for their style, rugged outdoor IP rating, and their very bright 2,000 lumen quad chip RGBW output, making them truly stand alone in their category. The bright output can light to the tops of medium sized trees and three story buildings, smoothly wash walls, provide temporary lighting to architectural details, and beautifully light the insides of tents and rooms.

QolorPoint Uplighters are available in a six unit charging case for fast and easy transport, and convenient recharging between uses. This system is perfectly geared to daily use in a variety of venues.

All battery powered QolorPoint Wireless LED Uplighters come equipped with City Theatrical's revolutionary Multiverse wireless DMX/RDM technology built in on the 2.4GHz band. They can either operate in master/slave mode, with one unit designated as a Transmitter and the others as Receivers, or all units can be designated as Receivers and can be broadcast to by a City Theatrical transceiver, including: Multiverse SHoW Baby®, Multiverse Node, or Multiverse Transmitter. All units can also operate independently and run their own internal stand alone routines.

<b>Name</b>	<b>QolorPoint Wireless LED Uplighter</b>			
<b>Application</b>	Outdoor (IP65) /indoor			
<b>Wireless Control</b>	Multiverse wireless DMX/RDM 2.4GHz (also fully compatible with SHoW DMX wireless DMX/RDM)			
<b>Wireless Range</b>	200 ft.			
<b>SHoW IDs</b>	Multiverse: 147 SHoW DMX Neo: 6			
<b>Runtime Fully Charged*</b>	Output Mode	Internal Effects	2 Colors	4 Colors
<i>*Note: Even longer battery life is obtainable by reducing brightness level.</i>	Long Life Mode	16 hrs	16 hrs	7 hrs 30 min
	Normal Mode	8 hrs	8 hrs	3 hrs 40 min
	<b>Recharge Time</b>	5 Hrs		
<b>Light Output</b>	2000 Lumens			
<b>Beam Angle</b>	15°			
<b>Color Type</b>	RGBW			
<b>Color Temperature</b>	R- 625nm, G- 527nm, B- 457nm, 4000°K			
<b>Operating Temperature</b>	-4° F to 113° F			
<b>Input Power (Charging)</b>	120-240VAC			
<b>Battery Type</b>	Li-Ion			
<b>Power Connectors</b>	Accessory			
<b>Data Connectors</b>	Accessory			
<b>Dimensions</b>	6.63" Dia.x 9.5" H. (168mm Dia. x 241mm H.)			

Part Number	Name
7000	QolorPoint Wireless LED Uplighter
7010	QolorPoint Wireless LED Uplighter, 6 Units & Charging Case
7015	QolorPoint Charging Case for 6 LED Uplighters
7020	QolorPoint Shroud, Black
7022	QolorPoint Shroud, White
7024	QolorPoint Power Supply Adaptor, Single Unit
7026	QolorPoint Battery Charger, Single Unit
7003	QolorPoint Lens Mount
7004	QolorPoint 30° x 30° Diffuser
7005	QolorPoint 60° x 60° Diffuser
7006	QolorPoint 60° x 10° Diffuser
7007	QolorPoint Hanging Bracket
7008	QolorPoint DMX Output Cable

800.230.9497 or 201.549.1160

# Aquafo<sup>g</sup> 3300™

Part Number: 3300



This water-based system is light-weight, portable, and durable, allowing you to create large amounts of billowing fog. The Aquafo<sup>g</sup> 3300 features a durable molded thermoplastic tank for corrosion resistance and light weight. No more rusting steel drums to replace. The large lid lifts for easy loading of dry ice. Stainless steel pump brings heated water from the tank up to the dry ice. A 6" (152.4 mm) fan pressurizes the tank and sends the fog out to the stage.

## TANK

The heart of the Aquafo<sup>g</sup> 3300 is our custom designed molded plastic tank. Plastic is both lightweight and corrosion resistant, and many of the plumbing and electrical fittings use pressure seals to ensure extended leak-proof use. The large lid makes it easy to lay the ice in the machine.

## ELECTRICAL

Aquafo<sup>g</sup> 3300 conveniently plugs into wall outlets. Circuit breakers control the dual heating elements, fan, and pump. Indicator lights show the status of the water temperature and heating elements at a glance. A low water level cutout switch assures that the heaters will not operate if the water is low. The sophisticated adjustable water temperature circuit will bring the temperature from a range of 100 through 160 degrees (F) (38 through 71 (C)) and will maintain temperature all through your long rehearsals. The convenient 4-plug system allows for easy remote control.

## DOLLY

The large rear wheels and the front swivel casters make moving a breeze.

**There is simply no substitute for dry ice fog. Nothing else is as thick and hugs the ground as tightly as real dry ice fog from City Theatrical.**

## SPECIFICATIONS

MODEL	Aquafo <sup>g</sup> 3300
Part Number	3300 (120v) / 3303 (230v)
Material	High temperature plastic polymer
Dimensions	21 1/2" x 31" x 38" (including casters) (546mm x 787mm x 965mm)
Water Capacity	28 gallons (106 litres)
Ice Capacity	75 lbs. (34kg)
Casters	3 1/2" (88.9mm) swivel front, 8" (203mm) fixed rear
Hose Vent	4" (101.6mm) molded into tank
Fill Door	20" x 30" (508mm x 762mm)
Weight Empty	115 lbs. (52kg)
Shipping Weight	130 lbs. (59kg)
Loaded Weight	455 lbs. (208.19kg)
Plumbing Fittings	All stainless, brass or high temperature plastic
Pump	Stainless steel 10GPM (37.85 litres/min.)
Heating Elements	120v 1650 watt / 230v 3000 watt (two)
Thermostat	Adjustable automatic control (100°F-160°F) (38°C-71°C)
Overtemperature	175°F (79°C) cutout, manual reset
Low water cut-out	Turns off heaters when water is low
Blower	240 CFM axial (6.799 CMM)
Circuit Breakers	20 amp on heating element 2 amp (lighted) on fan & pump

## FOG ACCESSORIES



PART NUMBER	NAME
3301	4" (101mm) Hose (25 foot, 7.6m)
3311	4" (101mm) Coupling
3312	4" (101mm) Wye

# Candle Lite™ Unlimited



Incredibly realistic electronic flicker candles specifically designed for live entertainment.

- Candle stick holds 9V battery and has integral switch
- Candle kit has slim circuit board to make your custom designs easier
- All candles are available with LED light source for longer battery life

PART NUMBER	NAME	
3450	Candle Kit (Incandescent)	
3451	Candle Kit (LED)	
3470	Candle Stick (Incandescent) 5" (127mm)	
3471	Candle Stick (LED) 5" (127mm)	
3472	Candle Stick (Incandescent) 12" (305mm)	
3473	Candle Stick (LED) 12" (305mm)	
3480	AC Adapter for One Candle, Dimmable	
3484	AC Adapter for One Candle, Not Dimmable	
3485	AC Adapter for Six Candles, Not Dimmable	



Company  
 Lighting Design: Neil Austin  
 Set Design: Bunny Christie  
 Photographer: Brinkhoff Moegenburg  
 Products used include Candle Lite Unlimited

## DMX Iris



- Based on the proven and reliable AutoYoke® iris
- Plugs into a 24VDC power supply (such as Forerunner™ or ChromaQ™) with a four pin cable
- Units can daisy chain to scrollers or to other DMX Irises

PART NUMBER	NAME
2192	DMX Iris for Source Four* (does not include power supply)
2199	Power Supply for up to 2 Irises

## Broadway Music Stand Light



- This is the light specified by many Broadway shows and tours
- The light from the fixture stays on the music and out of the eyes of the audience

PART NUMBER	DESCRIPTION
4200	Broadway Music Stand Light (T-10 bulb not included)

## Projector Dowser



- Changes “video black” to complete blackout
- DMX controlled
- Plugs into a 24VDC power supply (such as Forerunner™ or ChromaQ™) with a four pin cable
- Fits most video projectors

PART NUMBER	NAME
4160	Projector Dowser (does not include power supply)
2199	Power Supply for up to 2 Dowzers

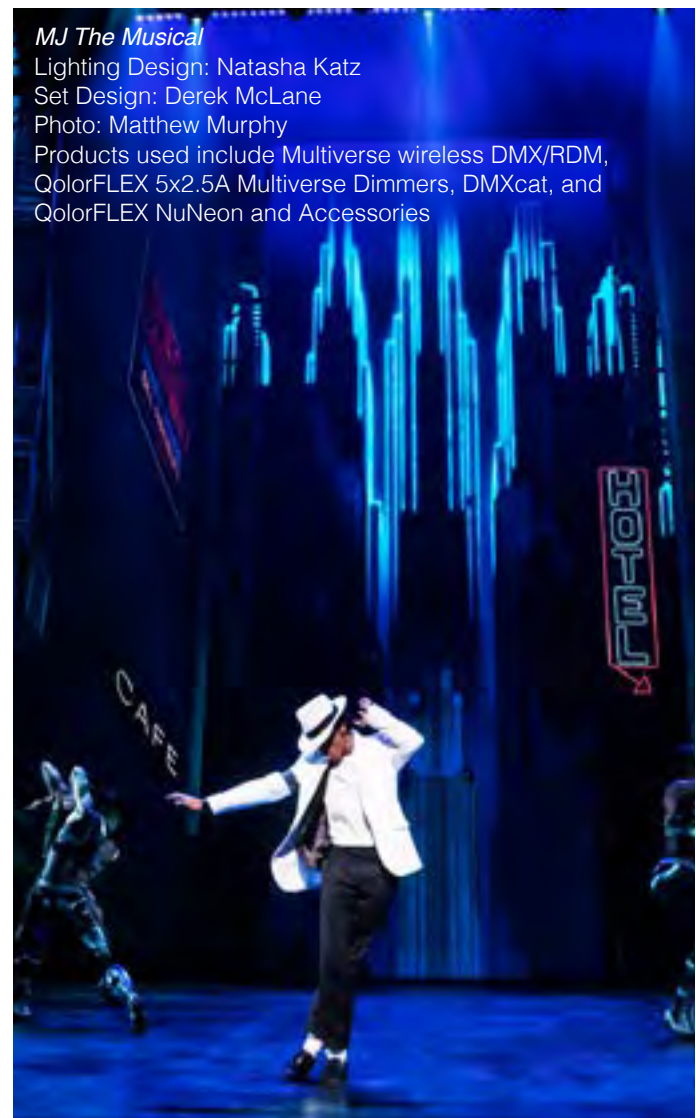

### *MJ The Musical*

Lighting Design: Natasha Katz

Set Design: Derek McLane

Photo: Matthew Murphy

Products used include Multiverse wireless DMX/RDM, QolorFLEX 5x2.5A Multiverse Dimmers, DMXcat, and QolorFLEX NuNeon and Accessories

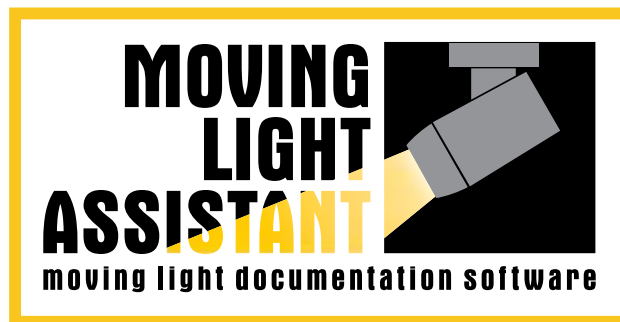

# Moving Light Assistant™

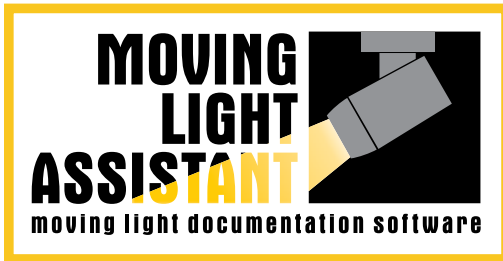

**Moving Light Assistant is an application designed to document both the physical setup and programming information for moving light rigs commonly used in the entertainment industry.**

The application will run on both Apple Mac OSX (Intel only) and Microsoft Windows operating systems.

## Features

- Spreadsheet view showing configuration (lenses, lamps, menu options etc.) of moving light fixtures in the rig.
- Design and Edit moving light gobo, color, and effect wheel loads.
- Integrated Gobo and Fixture library. Easily customized and updated.
- Import console reports from leading lighting consoles.
- View cue list, cue data, and channel data. Examine channel usage including maximum intensity, preset use, redundant moves, and more.
- Track current cue and photographs in the cue list with the lighting console in real time using Midi Show Control.
- Design, print, or generate PDF paperwork reports.
- Import and Export rig data with Lightwright.
- Take photographs directly into the application with a compatible DSLR camera connected via USB.

PART NUMBER	NAME
3660	Personal Moving Light Assistant
3665	Institutional Moving Light Assistant
3670	Student Moving Light Assistant

**Moving lights are complex.  
Moving Light Assistant keeps you organized.**



*Plaza Suite*  
Lighting Design: Brian MacDevitt  
Set Design: John Lee Beatty  
Photographer: Joan Marcus  
Products used include Moving Light Assistant software



## Beam Control Accessories: Achieve Your Vision

City Theatrical has worked with professional lighting designers to create high quality lighting accessories for over thirty years. Our mission is to create products, like Concentric Rings, that enable designers to achieve their artistic vision and make a performance or installation even better. Just let us know how we can help you.



MAC Aura PXL  
Concentric Ring  
(P/N 277)

800.230.9497 or 201.549.1160

## Beam Control Accessory Sizes for ETC Standard, EDLT, and XDLT Lenses for Source 4 LED Series 3

Lens Degree	Lens Type	Beam Control Accessory Size
90 Degree	Standard	7.5" x 7.5"
70 Degree	Standard	7.5" x 7.5"
	XDLT*	
50 Degree	Standard	6.25" x 6.25"
	EDLT	
	LED EDLT	7.5" x 7.5"
	XDLT*	
36 Degree	Standard	6.25" x 6.25"
	EDLT	
	XDLT*	7.5" x 7.5"
26 Degree	Standard	6.25" x 6.25"
	EDLT	
	XDLT*	7.5" x 7.5"
19 Degree	Standard	6.25" x 6.25"
	EDLT	
	XDLT*	10" x 10"
14 Degree	Standard	7.5" x 7.5"
	XDLT*	10" x 10"
10 Degree	Standard	12" x 12"
	XDLT*	14" x 14"
5 Degree	Standard	14" x 14"
	XDLT*	17.5" x 17.5"



17.5" Top Hat (P/N 2459)  
for ETC S4 LED Series 3  
5-Degree XDLT Lens

City Theatrical Beam Control accessories that fit various ETC Standard, EDLT, and XDLT Lenses for Source 4 LED Series 3 light fixtures include:

- Adapter
- Barndoor
- Beam Bender
- Color Extender
- Color Frame
- Concentric Ring
- Cross Baffle Top Hat for S4 PAR
- Donut
- Drop In Boomerang
- Egg Crate Louver
- Image Multiplexer
- Mainframe
- Stackers™ Tapered Top Hat
- Stackers™ Tapered Half Top Hat
- Standard Top Hat
- Standard Half Top Hat

## Stackers™ Tapered Top Hats



Stackers™

Tapered so they stack, but they don't stick together.

- Lightweight aluminum construction
- Black flocked interior
- Saves space in storage and transport

Stackers™ fit Source Four, Source Four PAR, Source Four Jr, Source Four Zoom, Selecon Pacific, Altman Shakespeare, and many others. Sorry, Stackers™ do not fit Strand SL, or Source Four 14° and may not fit all lighting fixtures. Please call us with any questions.



PART NUMBER	NAME	A	B	C	D
2840	6¼" Full Top Hat	6¼"	5"	5"	5 3/8"
2842	6¼" Short Full Top Hat	6¼"	5 1/8"	3"	5 3/8"
2850	7½" Full Top Hat	7½"	6"	6"	6¾"
2852	7½" Short Full Top Hat	7½"	6 3/8"	3"	6¾"
2860	10" Full Top Hat	10"	8"	8"	8 7/8"
2862	10" Short Full Top Hat	10"	8½"	4"	8 7/8"
2870	12" Full Top Hat	12"	10"	10"	10¾"
2872	12" Short Full Top Hat	12"	10 3/8"	5"	10¾"
2880	14" Full Top Hat	14"	12"	12"	13 3/8"
2882	14" Short Full Top Hat	14"	12 3/4"	6"	13 3/8"
<b>NEW</b> 2891	Adapter, for 7½" Stacker	7½"	7½"	6.8"	
<b>NEW</b> 2892	Adapter, for 10" Stacker	10"	10"	9.15"	

## Stackers™ Tapered Half Top Hats



Stackers™

Round frames allow Stackers Half Top Hats to rotate to the most advantageous angle.



PART NUMBER	NAME	A	B	C	D
2841	6 1/4" Half Top Hat	6¼"	5"	5"	5 3/8"
2843	6 1/4" Short Half Top Hat	6¼"	5 1/8"	3"	5 3/8"
2851	7½" Half Top Hat	7½"	6"	6"	6¾"
2853	7½" Short Half Top Hat	7½"	6 3/8"	3"	6¾"
2861	10" Half Top Hat	10"	8"	8"	8 7/8"
2863	10" Short Half Top Hat	10"	8½"	4"	8 7/8"
2871	12" Half Top Hat	12"	10"	10"	10¾"
2873	12" Short Half Top Hat	12"	10 3/8"	5"	10¾"
2881	14" Half Top Hat	14"	12"	12"	13 3/8"
2883	14" Short Half Top Hat	14"	12¾"	6"	13 3/8"
<b>NEW</b> 2891	Adapter, for 7½" Stacker	7½"	7½"	6.8"	
<b>NEW</b> 2892	Adapter, for 10" Stacker	10"	10"	9.15"	

**Note:**

Stackers and Standard Top / Half Top Hats are also available in white (no flocking on inside) at no additional charge. Add a "W" to the catalog number when ordering. Also available in white outside/black inside, with and without flocking. Call for pricing.

# Standard Top Hats



Standard Top Hat (P/N 2480) for ETC's Source 4 PAR

Top Hats control spill light and prevent the audience or viewers from seeing the bright and possibly distracting source of the light. They have a black flocked interior. Call for information on optional safety cables.

PART NUMBER	NAME	A	B	C	D
2222	Gantom 1	1 3/4"	1 3/4"	1 3/4"	1 3/4"
2232	Gantom DMX FL	1 1/2"	1 1/2"	1"	1"
2242	Gantom Precision Z	1 1/4"	1 1/4"	1"	1"
2570	S4 Mini	2.76"	2.76"	2.3"	2.3"
2571	Short S4 Mini	2.76"	2.76"	1.5"	2.3"
2455	PAR 16	2 7/8"	2 7/8"	2"	2"
2456	PAR 20	3 1/4"	3 1/4"	2 1/2"	2 1/2"
2457	3" Fresnel	3 3/4"	3 3/4"	3"	3"
2454	3 1/2" Ellipsoidal	4 1/8"	4 1/8"	3 1/2"	3 1/2"
<b>NEW</b> 2612	ColorSource Spot Jr. Top Hat	5.45"	5.45"	4.0"	4.1"
2590	D-22	5.55"	5.55"	3"	4.95"
2450	S4, SL, SH, PC*	6 1/4"	6 1/4"	5"	5"
<b>NEW</b> 2440	Short S4, SL, SH, PC*	6 1/4"	6 1/4"	3"	5"
<b>NEW</b> 2746	Martin Rush PAR 2 Zoom	6.38"	6.38"	2.99"	5.5"
2400	6" Ellipsoidal	7 1/2"	7 1/2"	6"	6"
2480	S4 PAR**	7 1/2"	7 1/2"	6"	6 3/4"
2481	Short S4 PAR**	7 1/2"	7 1/2"	3"	6 3/4"
2490	S4 PAR Round Frame**	7 1/2"	7 1/2"	6"	6 3/4"
2491	Short S4 PAR Round Frame **	7 1/2"	7 1/2"	3"	6 3/4"
2453	PAR 64 (Altman and L&E)	10"	10"	8"	8"
<b>NEW</b> 2445	Short PAR 64 (Altman & L&E)	10"	10"	3"	8"
2521	Altman AP150	7.875"	8.25"	3"	7.11"
2580	D-60	8 7/8"	8 7/8"	6"	8"
2581	D-60 short	8 7/8"	8 7/8"	3"	8"
2550	Selador 11"	10 5/8"	5 1/16"	4 3/4"	
2452	S4 10°, SL 10°	12"	12"	10"	10"
2448	Short S4 10°, SL 10°	12"	12"	5"	10"
<b>NEW</b> 2451	S4 5°	14"	14"	12"	12"
2458	SL 5°	16"	16"	14"	14"
2459	17.5"	17 1/2"	17 1/2"	15 1/2"	15 1/2"
2402	125mm	125mm	125mm	100mm	100mm
2404	185mm	185mm	185mm	150mm	150mm
2406	245mm	245mm	245mm	205mm	205mm



\* Source Four, Strand SL, Shakespeare, and Pacific ellipsoidals (19-50°)

\*\* These accessories can also be used with S4 PARNel, S4 Zoom fixtures, S4 14°, and ETC D-40.

**Note:** We do not recommend the use of 5" long accessories in 50° lens tubes. We do not recommend the use of any accessories in 70° or 90° lens tubes. Extreme loss of light will occur.

## Standard Half Top Hats



Half Top Hats mask the beam on one side, and allow max light output on the other side. They have a black flocked interior.

PART NUMBER	NAME	A	B	C	D
2572	S4 Mini	2.76"	2.76"	2.3"	2.3"
2573	Short S4 Mini	2.76"	2.76"	1.5"	2.3"
2465	PAR 16	2 7/8"	2 7/8"	2"	2"
2466	PAR 20	3 1/4"	3 1/4"	2 1/2"	2 1/2"
2467	3" Fresnel	3 3/4"	3 3/4"	3"	3"
2464	3 1/2" Ellipsoidal	4 1/8"	4 1/8"	3 1/2"	3 1/2"
<b>NEW</b> 2614	ColorSource Spot Jr.	5.45"	5.45"	4"	4.1"
2591	D-22	5.55"	5.55"	3"	4.95"
<b>NEW</b> 120-000010-03	ColorBlast 6, White	5 5/8"	4 5/8"	3"	
<b>NEW</b> 120-000010-04	ColorBlast 6, Black	5 5/8"	4 5/8"	3"	
2460	S4, SL, SH, PC*	6 1/4"	6 1/4"	5"	5"
2441	Short S4, SL, SH, PC*	6 1/4"	6 1/4"	3"	5"
2420	6" Ellipsoidal	7 1/2"	7 1/2"	6"	6"
2482	S4 PAR**	7 1/2"	7 1/2"	6"	6 3/4"
2482S	Short S4 Par	7 1/2"	7 1/2"	3"	6 3/4"
2492	S4 PAR Round Frame**	7 1/2"	7 1/2"	6"	6 3/4"
<b>NEW</b> 2522	Altman AP150	7.785"	8.25"	3"	7.11"
2582	D-60	8 7/8"	8 7/8"	6"	8"
<b>NEW</b> 2463S	Short PAR 64 (Altman, L&E)	10"	24"	24"	10"
2463	PAR 64 (Altman and L&E)	10"	10"	8"	8"
2462	S4 10°, SL 10°	12"	12"	10"	10"
<b>NEW</b> 120-000009-03	ColorBlast 12, White	12 1/2"	5 3/8"	3"	
<b>NEW</b> 120-000009-04	ColorBlast 12, Black	12 1/2"	5 3/8"	3"	
2461	S4 5°	14"	14"	12"	12"
2468	SL 5°	16"	16"	14"	14"
<b>NEW</b> 2469	17.5"	17 1/2"	17 1/2"	15 1/2"	15 1/2"
2442	125mm	125mm	125mm	100mm	100mm
2444	185mm	185mm	185mm	150mm	150mm
2541	Kreios FL 60w and FLx 90w	239mm	239mm	108mm	156mm
2446	245mm	245mm	245mm	205mm	205mm



Standard Half Top Hat (P/N 2482) for ETC's Source 4 PAR



\* Source Four, Strand SL, Shakespeare, and Pacific ellipsoidals (19-50°)

\*\* These accessories can also be used with S4 PARnel, S4 Zoom fixtures, S4 14°, and ETC D-40.

**Note:** We do not recommend the use of 5" long accessories in 50° lens tubes. We do not recommend the use of any accessories in 70° or 90° lens tubes. Extreme loss of light will occur.

## Color Frames

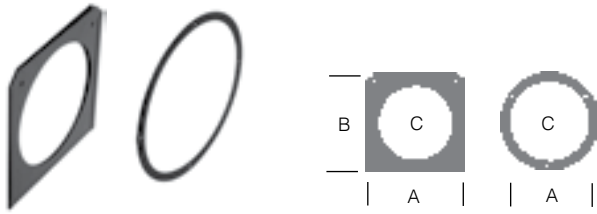

- Fabricated from durable cold rolled steel with hemmed edges
- Tough black powder coated finish
- Round style S4PAR units are available for architectural use

PART NUMBER	NAME	A	B	C
2319	MiniStrip (rect opening)	4 11/16"	3 5/16"	—
<b>NEW</b> 2320	R40	5 3/4"	6 3/4"	5"
2616	ColorSource Spot Jr.	5.45"	5.45"	4.06"
2593	D-22	5.55"	5.55"	3"
2350	S4, SL, SH, PC*	6 1/4"	6 1/4"	5"
2350A	S4, SL, SH, PC*, Aluminum	6 1/4"	6 1/4"	5"
<b>NEW</b> 2742	Martin MAC Rush PAR 2	6.38"	6.38"	—
2300	6" Ellipsoidal	7 1/2"	7 1/2"	6"
2487	S4 PAR**	7 1/2"	7 1/2"	6 3/4"
2497	S4 PAR** (Round)	7 1/2"	7 1/2"	6 3/4"
<b>NEW</b> 2323	Altman AP150	7.875"	8.25"	7.25"
2321	City Ground Cyc	8 3/4"	13"	—
2322	PAR 64	10"	10"	8"
2328	S4 10°, SL 10°	12"	12"	10"
2329	S4 5°	14"	14"	12"
2330	City Sky Cyc	15 1/2"	15 7/8"	—
2338	City Far Cyc	14 3/4"	15 1/2"	—
2348	SL5°	16"	16"	14"
<b>NEW</b> 2331	17.5"	17 1/2"	17 1/2"	15 1/2"
2302	125mm	125mm	125mm	100mm
2304	185mm	185mm	185mm	150mm
2306	245mm	245mm	245mm	205mm

\* Source Four, Strand SL, Shakespeare and Pacific ellipsoidals (19-50°)

\*\* These accessories can also be used with S4 PARNel, 14" Zoom Fixtures, S4 14" and, ETC D-40

**Note:** The Mainframes fiber material is flameproof and will not burn, but some hot lights will cause it to dry and crack. Best performance is with hard edge ellipsoidals like Source Four.

## Mainframes®



- Lightweight, flameproof, gray fiberboard color frames
- Simple, safe, and inexpensive
- Secures with a single heavy-duty staple
- Available in a wide range of sizes

PART NUMBER	NAME	A	B	C
2352	"Inkie"	3 3/4"	3 3/4"	3"
2358	"Mini Strip" (2 hole style)	4 11/16"	3 5/16"	—
2359	"Mini Strip" (rect. opening)	4 11/16"	3 5/16"	—
2360	Zip Strip	4 3/4"	4 3/8"	—
2362	R40	5 3/4"	6 3/4"	5"
2364	S4, SL, SH, PC*	6 1/4"	6 1/4"	5"
2366	6" Ellipsoidal	7 1/2"	7 1/2"	6"
2367	Source Four™ PAR**	7 1/2"	7 1/2"	6 3/4"
2376	PAR 64	10"	10"	8"
2382	10° Source Four™	12"	12"	10"
2383	5° Source Four™	14"	14"	12"
2385	100 mm	100mm	100mm	80mm
2387	125mm	125mm	125mm	100mm
2389	150mm	150mm	150mm	125mm
2391	185mm	185mm	185mm	150mm
2393	230mm	230mm	230mm	165mm
2395	245mm	245mm	245mm	205mm



*Mrs. Doubtfire*  
 Lighting Design: Philip Rosenberg  
 Set Design: David Korins  
 Photographer: Joan Marcus  
 Products used include Vari-Lite and GLP Beam Control Accessories

## HOLDERS for Glass Gobos



Part Number	2171	2170	2173	2178	2172	2175	2166	2146
<b>Name</b>	S4 "A" (iris slot)	S4 "B"	S4 86mm OD glass* (gobo slot)	S4 86mm OD Glass (iris slot)	S4 "B" (iris slot)	S4 Jr. "M"	S4 Jr. "M" Iris Slot	SL "B"
<b>A</b>	4 11/16"	3 11/16"	3 11/16"	4 11/16"	4 11/16"	2 11/16"	3 1/8"	4 3/16"
<b>B</b>	3 3/16"	2 3/4"	2 3/4"	2 3/4"	2 3/4"	2 5/32"	1 5/8"	2 3/4"
<b>GLASS OD</b>	100mm	82mm	86mm	86mm	82mm	66mm	48mm	82mm

Part Number	2147	2115	2105	2130	2140	2051	2061
<b>Name</b>	SL 86mm OD glass*	Selecon Pacific 86mm OD glass*	Selecon Acclaim Axial	360Q/ Shakespeare	SL "B" Old Style	S4 "A" Tabbed (Iris Slot)	S4 "B" Tabbed
<b>A</b>	4 3/16"	4 1/2"	3 3/4"	3 5/16"	3 1/2"	4 11/16"	3 11/16"
<b>B</b>	2 3/4"	2 27/32"	2 1/8"	2 3/4"	3"	3 3/16"	2 3/4"
<b>GLASS OD</b>	86mm	86mm	66mm	82mm	82mm		

## HOLDERS for Metal Gobos

- Large heat resistant ring pulls
- Aluminum construction acts as a heat sink to minimize pattern warpage



Part Number	2150	2160	2165	2144	2114	2120	2190	2106	2050	2060
<b>Name</b>	S4 "A"	S4 "B"	S4 Jr. "M"	SL "B"	Selecon Pacific "B"	360Q/ Shakespeare	Colortran Style (5/50 Series)	Selecon Acclaim Axial	S4 "A" Tabbed	S4 "B" Tabbed
<b>A</b>	3 11/16"	3 11/16"	2 11/16"	4 3/16"	4 1/2"	3 5/16"	4"	3 3/4"	3 11/16"	3 11/16"
<b>B</b>	3 3/16"	2 3/4"	2 5/32"	2 3/4"	2 3/4"	2 3/4"	3 1/16"	2 1/8"	3 3/16"	2 3/4"

800.230.9497 or 201.549.1160

## Egg Crate Louvers

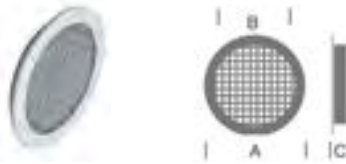

Egg Crate Louvers serve a similar function to a Top Hat, but do so in only 1/2" of depth. A 45 degree cut-off is obtained by using cells that are 1/2" x 1/2", by 1/2" deep. Egg Crate Louvers give a sleek appearance to the lighting fixture while providing good beam control.

PART NUMBER	NAME	A	B	C
2592	D-22	5.55"	4.69"	5/16"
2499	S4 Ellipsoidal	6 1/4"	6 1/4"	1/2"
2485	S4 PAR*	7 1/2"	7 1/2"	1/2"
2536	Altman AP150	7.875"	6.70"	0.520"
2585	D-60	8 7/8"	7 3/4"	1/2"
2552	Selador 11"	10 5/8"	6 1/4"	1/2"
2486	185mm	185mm	185mm	13mm

\*Fits D-40

## Donuts

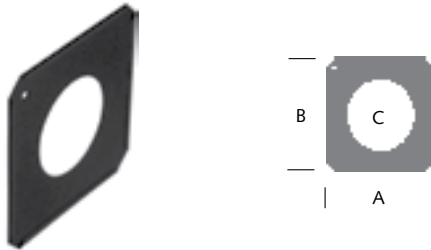

Donuts are used to help bring templates into perfect sharpness. They are fabricated from light gauge steel, with a durable black powder coated finish.

PART NUMBER	NAME	A	B	C
2575	S4 Mini	2.76"	2.76"	2.3"
2618	ColorSource Spot Jr. Donut	5.45"	5.45"	1.97"
2250	S4, SL, SH, PC* (3 3/16" center hole)	6 1/4"	6 1/4"	3 3/16"
2260	S4, SL, SH, PC* (2 1/2" center hole) **	6 1/4"	6 1/4"	2 1/2"
2200	6" Ellipsoidal, S4 Zoom	7 1/2"	7 1/2"	3"
2201	7.5", w/ 2.5" Aperture	7 1/2"	7 1/2"	2 1/2"
2202	7.5", w/ 3.5" Aperture	7 1/2"	7 1/2"	3 1/2"
2218	10" Donut	10"	10"	4"
2252	S4 10°, SL 10°	12"	12"	6"
2251	S4 5°	14"	14"	7"
2258	SL 5°	16"	16"	7"
2259	17.5" Donut	17 1/2"	17 1/2"	10"
2208	125mm	125mm	125mm	81mm
2210	185mm	185mm	185mm	81mm

## Concentric Rings

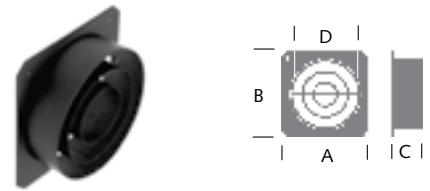

- Offers full control of stray beams and spill
- Fabricated from light gauge steel with hemmed edges
- Comparable function to a full 6 inch Top Hat
- Black powder coated finish

PART NUMBER	NAME	A	B	C
2484	S4 PAR	7 1/2"	7 1/2"	2"
2493	PAR 64	10"	10"	2"
2494	185mm	185mm	185mm	51mm

## Color Extenders

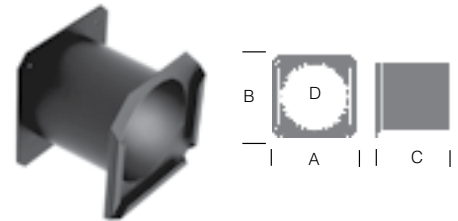

- Saves both time and aggravation by preventing gel burnout
- Fabricated from durable cold rolled steel with hemmed edges
- Gel materials are placed in slot at front of unit, forward of the fixture's focal plane
- Available in white, see page 52 for information

PART NUMBER	NAME	A	B	C
2470	S4, SL, SH, PC*	6 1/4"	6 1/4"	5"
2471	Short S4, SL, SH, PC*	6 1/4"	6 1/4"	3"
2410	6" Ellipsoidal	7 1/2"	7 1/2"	6"
2430	Short 6" Ellipsoidal	7 1/2"	7 1/2"	3"
2483	S4 PAR**	7 1/2"	7 1/2"	6"
2483A	Short S4 PAR**	7 1/2"	7 1/2"	3"
2473	PAR 64 (Altman and L&E)	10"	10"	5"
2474	125mm	125mm	125mm	76mm
2476	185mm	185mm	185mm	127mm
2478	245mm	245mm	245mm	127mm

\* Source Four, Strand SL, Shakespeare, and Pacific ellipsoidals (19-50°)

\*\* These accessories can also be used with S4 PARNel, S4 Zoom fixtures, and S4 14°.

**Note:** We do not recommend the use of 5" long accessories in 50° lens tubes. We do not recommend the use of any accessories in 70° or 90° lens tubes. Extreme loss of light will occur.



## Barndoors

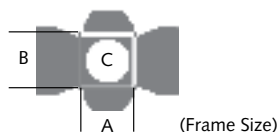

Barndoors provide adjustable beam control. Movable doors can be set to cut off stray beams where needed, such as off of scenery or projection screens.

PART NUMBER	NAME	A	B	C
2230	Gantom DMX FL	1 1/4"	1 1/4"	3/4"
2240	Gantom Precision Z	1 1/4"	1 1/4"	3/4"
2220	Gantom 1	2 1/2"	2 1/2"	1 3/4"
2574	S4 Mini, Black	2.76"	2.76"	2"
2599	D-22	5.55"	5.55"	4.95"
2488	S4 PAR/PARnel*	7 1/2"	7 1/2"	6 3/4"
2488S	S4 PAR/PARnel (short)	7 1/2"	7 1/2"	6 3/4"
2568	S4 Fresnel 8 Leaf	7 1/2"	7 1/2"	6 3/4"
<b>NEW</b> 2561	Altman AP150	7.88"	7.88"	7.18"
2500	6 1/4"	6 1/4"	6 1/4"	5 1/4"
2588	D-60	8 7/8"	8 7/8"	8"
<b>NEW</b> 2496	10"	8 7/8"	8 7/8"	8"
2554	Selador 11"	10 5/8"	4 1/16"	—
2542	KREIOS® FL 60W and FLx 90W	12"	9.5"	10"
510 or 510C	Philips SL Nitro	18 1/4"	3 1/4"	14 1.2"
2489	185mm	185mm	185mm	171mm

\*Fits D-40

## Image Multiplexer™



The Image Multiplexer expands and multiplies gobo images from standard stage lighting instruments. It is a lens accessory which drops into the color frame slot.

PART NUMBER	NAME
1450	Image Multiplexer

## Drop In Iris

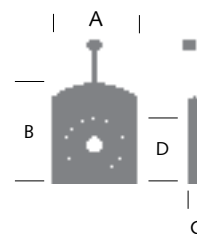

- Offers precise, smooth control of beam size
- Specially made leaves are tempered and heat resistant to over 1000°F
- CTI Irises carry a limited lifetime warranty (See website for details)

PART NUMBER	NAME	A	B	C	D
2185	Source Four Jr. Iris	3 1/8"	4 9/32"	1/2"	2 5/16"
2186	Strand SL Iris	4 3/16"	5 3/16"	1/2"	3"
2180	Source Four Iris	4 25/32"	5 7/16"	1/2"	3"

## Adapter



6 1/4" to 7 1/2" unit allows use of 7 1/2" accessories (color wheels, scrollers, etc.) with Source Four™ fixtures. The 7 1/2" to 6 1/4" allows the use of 6 1/4" S4 accessories with 7 1/2" fixture.

PART NUMBER	NAME
1251	6 1/4" to 7 1/2" Adapter
1252	7 1/2" to 6 1/4" Adapter

## Source Four PAR Cross Baffle Top Hat

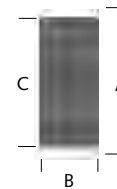

Provides 45° cut off in architectural installations.

PART NUMBER	NAME	A	B	C
2495	S4 PAR Cross Baffle Top Hat	7 1/2"	3"	6 3/4"

# Martin® Accessories



PART NUMBER	NAME	
2757	MAC 700 Profile Top Hat	
2758	MAC 700 Wash Top Hat	
2760	MAC 2000 Top Hat (fits Performance and Profile)	
2762	MAC 2000 Wash Top Hat	
2770	MAC 2000 Sound Baffle (Per pair, one pair required per fixture)	
2785	MAC Atomic 3000 Strobe Barndoor	
2791	MAC Aura Concentric Ring	
2793	MAC Aura Egg Crate	
2792	MAC Aura Top Hat	
104-00117	MAC Aura Mount Kit, including 4 clips and 4 screws	
<b>NEW</b> 2786	MAC Aura PXL Top Hat	
<b>NEW</b> 2787	MAC Aura PXL Hexcel Louver	
<b>NEW</b> 2788	MAC Aura PXL Concentric Ring	

PART NUMBER	NAME	
2790	MAC III Follow Spot Handle	
2778	MAC Encore Performance Top Hat	
2794	MAC Quantum Wash Hexcel Louver	
2795	MAC Quantum Wash Concentric Ring	
<b>NEW</b> 2744	MAC Rush MH6 Top Hat	
2782	MAC TW1 Color Frame	
2783	MAC TW1 Louver	
2780	MAC TW1 Top Hat	
2772	MAC Viper Performance Top Hat	
2774	MAC Viper Wash DX Top Hat	
2775	MAC Viper Wash DX Concentric Ring	
2776	MAC Viper Wash DX Hexcel Louver	



## Vari-Lite® Accessories

PART NUMBER	NAME		PART NUMBER	NAME	
2645	VL5 Full Concentric Ring		2654	VL3000 Wash Concentric Ring	
2698	VL500/1000 Floor Stand		2653	VL3500 Wash Top Hat	
2650	VL2000,VL2500 Top Hat		2661	VLX Louver	
2650 WIDE	VL2000,VL2500 Wide Top Hat		2660	VLX Top Hat	
2652	VL3000 Spot, VL3000 Wash, and VL3500 Spot Top Hat				



## CHAUVET Accessories

PART NUMBER	NAME	
2670	CHAUVET Rogue R2 Wash Top Hat	
<b>NEW</b> 2672	CHAUVET Maverick MK3 Profile Follow Spot Handle Kit	

## GLP X4® Accessories

PART NUMBER	NAME	
6375	GLP X4 Concentric Ring	
6376	GLP X4L Concentric Ring	
6377	GLP X4XL Concentric Ring	

## ETC® and High End Systems Accessories

PART NUMBER	NAME	
2700	ETC Releve Spot Top Hat	
2710	High End Systems Solaframe 1000 Top Hat	

**We can make Beam Shaping Accessories for any lighting fixture. Call us and we can help you solve your lighting challenges.**

# Source Four Follow Spot Yoke



Create your own follow spot with pan and tilt movement as smooth as the world's best follow spots and the tungsten color temperature that many designers prefer, or use the Source Four LED Ellipsoidals.

- Our #1500 is specifically designed to mount Source Fours® without springs or counterweights and was designed for Broadway and West End shows and tours of *Wicked*
- Fits Source Four 5° to 50° (not Zoom units)
- Perfectly adjusts balance without counterweights
- Pan and tilt bearings for smooth action
- Many accessories available

PART NUMBER	NAME
1500	Follow Spot Yoke for Source Four, Includes pan bearing
1502	Follow Spot Yoke for Source Four LED, Includes pan bearing
<b>NEW</b> 1504	Follow Spot Yoke for Source Four LED Series 3
1515	Follow Spot Yoke for Chauvet Ovation
1505	Source Four to Source Four Series 2 LED Retrofit Kit

## Beam Bender

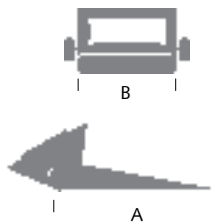

- Attaches easily to any 6 1/4" Source Four®, Strand SL™, Shakespeare™, or Selecon Pacific™ ellipsoidal
- Ideal for shooting around scenery or other obstruction; especially useful for dance designers needing maximum light output at floor level
- Adjustable mirror for controlling angle and spread of beam

PART NUMBER	NAME	A	B
1402	Beam Bender S4 Mini	5 1/2"	3 1/16"
<b>NEW</b> 1404	Beam Bender, Color-Source Spot Jr	12"	7"
1400	Beam Bender 6 1/4"	12"	7"
1401	Beam Bender 7 1/2"	14 3/4"	8 1/2"

## Blacktak™ Light Mask Foil



- Uses include: masking light spill, creating shadows, forming Barndoors, adapting gobos, and as a high temp tape
- High temperature adhesive is heat resistant
- Can be repositioned without leaving residue

PART NUMBER	NAME
3600	Blacktak 2" x 75'
3624	Blacktak 24" x 15'

## Follow Spot Drop In Iris



- Offers precise, smooth control of beam size
- Specially made leaves are tempered and heat resistant to over 1000°F

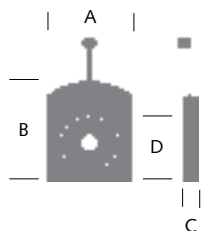

PART NUMBER	NAME	A	B	C	D
2180	Source Four Iris	4 25/32"	5 7/16"	1/2"	3"

## Follow Spot Pan Bearing



- Use this to make any lighting fixture into a follow spot
- Large pan bearing for smooth action

PART NUMBER	NAME
1510	Pan Bearing

## Lighting Shield

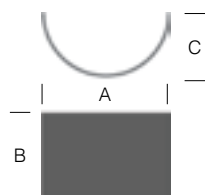

This half cylinder shield hides your floor mounted units

PART NUMBER	NAME	A	B	C
6371	Lighting Shield - Black	24"	12"	12"R
6371W	Lighting Shield - White	24"	12"	12"R
6371S	Lighting Shield - Silver	24"	12"	12"R
6370	Lighting Shield - Black	24"	16"	12"R
6370W	Lighting Shield - White	24"	16"	12"R

## Follow Spot Drop In Boomerang



- Holds six colors
- Reversible for either right or left handed operation
- Fits Source Four, Strand SL, Shakespeare or, Selecon Pacific ellipsoidals
- Boomerang handle perfectly balances Drop-in Boomerang



PART NUMBER	NAME	A	B	C	D
1410	Drop-in Boomerang 6 1/4"	11"	11"	4"	5 1/2"
1411	Drop-In Boomerang 7 1/2"	13 3/4"	13"	5"	6 1/2"
1415	Boomerang Handle				

## Follow Spot Handle



- Allows operator to easily control fixture movement
- Source Four handle attaches to the rear of the fixture by means of a clamp screw

PART NUMBER	NAME
1360	Follow Spot Handle, Source Four
1522	Follow Spot Handle, Source Four Series 1 or Series 2 LED
<b>NEW</b> 1519	Follow Spot Handle, Source Four Series 3 LED

## Follow Spot Yoke Handle



- Yoke handle screws into existing 5/16" side mounting hole, or can be attached to the lens tube of a 5° or 10° S4

PART NUMBER	NAME
1520	Follow Spot Yoke Handle

# Chroma-Q Color Force/Studio Force and Philips Color Kinetics® Accessories

## Top Hats



Control light spill and decrease viewing angle to lens.

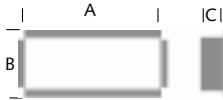

PART NUMBER	NAME	A	B	C
120-000006-04	Top Hat, ColorBlast 6, Black *	4 5/8"	4 5/8"	3"
120-000006-03	Top Hat, ColorBlast 6, White *	5 5/8"	4 5/8"	3"
120-000005-03	Top Hat, ColorBlast 12, White *	12 1/2"	5 1/4"	3"
120-000005-04	Top Hat, ColorBlast 12, Black *	12 1/2"	5 1/4"	3"

## Half Top Hats



Control light spill and decrease viewing angle to lens.



PART NUMBER	NAME	A	B	C
120-000010-03	Half Top Hat, ColorBlast 6, White *	5 5/8"	4 5/8"	3" tapering to 1/2"
120-000010-04	Half Top Hat, ColorBlast 6, Black *	5 5/8"	4 5/8"	3" tapering to 1/2"
120-000009-03	Half Top Hat, ColorBlast 12, White *	12 1/2"	5 1/4"	3" tapering to 1/2"
120-000009-04	Half Top Hat, ColorBlast 12, Black *	12 1/2"	5 1/4"	3" tapering to 1/2"

## Barndoors

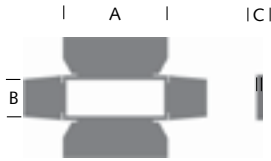

Barndoors provide adjustable beam control. Movable doors can be set to cut off stray beams where needed, such as off of scenery or projection screens.

PART NUMBER	NAME	A	B	C
120-000020-03	Barndoor, ColorBlast 6, White *	10 1/4"	6 1/4"	1"
120-000020-04	Barndoor, ColorBlast 6, Black *	10 1/4"	6 1/4"	1"
120-000019-03	Barndoor, ColorBlast 12, White *	16 1/2"	6 1/4"	1"
120-000019-04	Barndoor, ColorBlast 12, Black *	16 1/2"	6 1/4"	1"

## Egg Crate Louvers

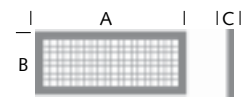

Controls light spill and provides 45 degree cutoff.

PART NUMBER	NAME	A	B	C
120-000016-03	Egg Crate Louver for ColorBlast 6, White *	5 5/8"	4 5/8"	1/2"
120-000016-04	Egg Crate Louver for ColorBlast 6, Black *	5 5/8"	4 5/8"	1/2"
120-000015-03	Egg Crate Louver for ColorBlast 12, White *	12 1/2"	5 1/4"	1/2"
120-000015-04	Egg Crate Louver for ColorBlast 12, Black *	12 1/2"	5 1/4"	1/2"

\* Also fits A.C. Lighting Color Force / Studio Force



Safer Sidearm Original  
(P/N 200)

800.230.9497 or 201.549.1160

## C-Clip Truss Protector™



- Designed to protect expensive truss from damage caused by fixture clamps
- Provides a sacrificial barrier that absorbs indentations, snaps onto 2" members, and is easy to remove

PART NUMBER	NAME
1370	C-Clip Truss Protector 2" (50mm) White
1371	C-Clip Truss Protector 2" (50mm) Black

## Ceiling Port for Source Four PAR or D-40

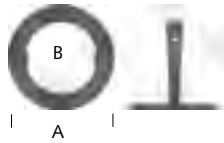

- Mount a Source Four Par or D-40 above a fixed ceiling
- Manually focusable in both pan and tilt
- Includes trim ring

PART NUMBER	NAME	A	B
1470	Ceiling Mount for Source Four PAR or D-40	13"	9"
1470W	Ceiling Mount for Source Four PAR or D-40, White (Built to order, 2 week delivery)	13"	9"

## 10" Boom Base



- 6 lb fixture base for use on floor or table
- 1/2" tapped center hole for fixture mounting
- Black finish
- Includes bolt and washer

PART NUMBER	NAME
4300	10" Boom Base

## Boom Tie Off



- Fits 1 1/2" pipe
- Rugged 1/2" steel rod welded to both sides of cap to withstand heavy lifting

PART NUMBER	NAME	A
1310	Boom Tie Off	5"

## ETC S4 LED Cyc Base



- Folds to 1 1/4" flat for storage
- Allows fixture to pivot 25°

PART NUMBER	NAME
4305	ETC S4 LED Cyc Base



## Scenery Bumper

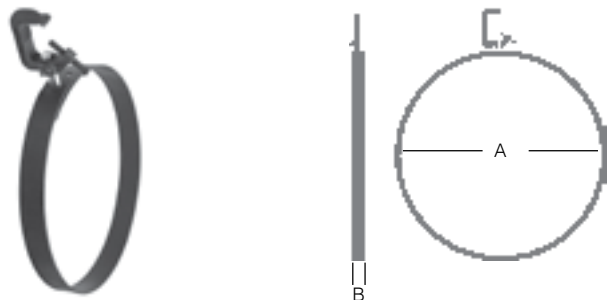



- 18" diameter ring attaches to fixture pipe with included C-clamp
- Protects fixtures from flying drops and passing scenery
- Saves refocusing time
- Includes C-clamp
- 3/16" steel construction, weight 8 lbs.

PART NUMBER	NAME	A	B
1340	Scenery Bumper	18"	2"

## Vertical Extension Tubes



- A simple way to raise or lower a piece of equipment relative to the hanging position
- Compatible with C-clamps, Track Tamers™ or each other

PART NUMBER	NAME
090	VET Adapter for Split Couplers (not pictured)
091	6" VET 
093	12" VET 
095	24" VET 

## Cable Hook



- Designed to help manage and support multi-cable runs with truss systems
- Lightweight aluminum construction
- Fits 1 1/2" to 2" truss pipe

PART NUMBER	NAME
1330	Cable Hook

## Sliding Tee



- Slides onto 1/2" pipe on sidearms
- Cast iron
- Allows full X-Y axis focusing

PART NUMBER	NAME
1130	Sliding Tee

## Projector Hanger



Used to hang projection equipment from a vertical pipe, the hanger allows for easy removal and replacement of projectors without having to unscrew the pipe coupling.



PART NUMBER	NAME
1140	Projector Hanger

# Moving Light Hangers™

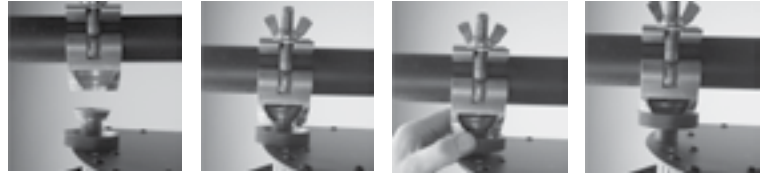
City Theatrical Moving Light Hangers allow moving lights to be swapped out with the new light in absolutely the same place as the old one. The key to the design is a tapered alignment seat that locks dead on, removing all possible variation.



- Patented flexible Tee Slot System
- Allows the user to hang and register a moving light to a predictable position
- Allows for fast and easy replacement of moving lights
- No refocusing of moving lights required
- Call for custom variations

PART NUMBER	NAME		USAGE
130	Tee Slot		Hang from scenery
137	Tee Slot for Unistrut®		Hang from Unistrut
138	Tee Slot w/integral Split Coupler		Hang from pipe or truss
135	Tee Head with Knob		Attach to moving light or conventional fixture. Use with 130, 137, or 138











City Theatrical Track Tamers

# Track Tamers™



Load-rated City Theatrical Track Tamers separate the lockdown of the track from the lockdown of the lighting fixture, making your job faster and safer.

Many lighting installations use Unistrut with Unistrut nuts, but Unistrut nuts are deficient when it comes to hanging lighting fixtures. To focus a lighting fixture, you must loosen the Unistrut nut and risk it popping out and leaving you with a lighting fixture in your arms at the top of a lift or ladder. City Theatrical Track Tamers were designed to overcome these problems. They have deep grooves that grip the track tightly to prevent it from coming out, and we separate the lockdown of the track from the lockdown of the lighting fixture. Track Tamers are safer and faster than standard Unistrut hardware for hanging entertainment lighting fixtures. All City Theatrical Track Tamers are CE certified and RoHS compliant, and have a Safe Working Load (SWL) of 250 lbs. when used in straight down position.







PART NUMBER	NAME		USAGE
520	Track Tamer with Hex Nut		Hang equipment from Unistrut®
520M	Track Tamer with Hex Nut (metric)		Hang equipment from Unistrut®
521	Track Tamer with Knob		Hang equipment from Unistrut®
521M	Track Tamer with Knob (metric)		Hang equipment from Unistrut®
523	Track Tamer with Aluminum Split Coupler		Adapt Unistrut® to pipe
525	Track Tamer with Galvanized Clamp and Hex Nut		Adapt Unistrut® to pipe
530	Track Tamer with Hex Nut and 5/8" Male Pin		Hang film or video equipment from Unistrut®
531	Track Tamer with Knob and 5/8" Male Pin		Hang film or video equipment from Unistrut®

800.230.9497 or 201.549.1160

# Safer Sidearms™



Let's face it, standard theatrical sidearms are poorly designed. They're weak, can't support any downward pressure, and the C-clamp that they use is easily bent and damaged. City Theatrical Safer Sidearms eliminate all these problems by adding a strong diagonal brace that transfers force to the vertical boom pipe. These are beautifully engineered devices that will give you years of service. Safer Sidearms are CE certified and RoHS compliant.

PART NUMBER	NAME		SAFE WORKING LOAD (SWL)	USAGE
200	Safer Sidearm Original (uses ½" Schedule 40 steel pipe)		50 lbs.	Safer Sidearm Originals (P/N 200, 202, and 204) are designed to replace the c-clamp on a standard sidearm. The units incorporate a half coupler and a vertical brace to create stability and are designed to transfer the weight load back to the structural pipe.
202	Safer Sidearm Original with 18" of ½" pipe and one sliding tee			
204	Safer Sidearm Original with 24" of ½" pipe and two sliding tees			
210	Steel Safer Sidearm (uses 1½" Schedule 40 steel pipe, not included)		200 lbs. with 3' arm	Steel Safer Sidearms (P/N 210) are used to hang speakers or moving lights.
211	1 ½" Pipe (per foot) drilled for Steel Safer Sidearm		-	1½" pipe only (P/N 211).
220	Safer Sidearm Junior (pipe not included)		50 lbs.	Safer Sidearm Junior (P/N 220) augments a standard sidearm by adding a vertical brace to an existing sidearm.
290	Pipe End Tail Down (includes 6 feet of 1½" pipe)		200 lbs.	Pipe End Tail Down (P/N 290) allows a pipe to be hung vertically and perpendicular to a horizontal theatre hanging position. It uses a double pipe clamp to attach to the structural pipe and comes with a six-foot piece of 1 ½" pipe and a 3/16" safety cable with shackle through the pipe.









# Breakaways



**A complete range of bottles and glasses in a variety of colors, sizes, and shapes.**

- Easy and safe way to simulate breaking glass in productions
- Breaks into realistic “glass” pieces
- Bottles and glasses sold in cases of six (6)

Part Number	3910	3911	3912	3913	3914	3915	3920	3921	3922
<b>Name</b>	Beer Bottle Long Neck (Clear)	Beer Bottle Long Neck (Brown)	Beer Bottle Long Neck (Green)	Beer Bottle Short Neck (Clear)	Beer Bottle Short Neck (Brown)	Beer Bottle Short Neck (Green)	Whiskey Bottle (Clear)	Whiskey Bottle (Brown)	Whiskey Bottle (Green)
									
<b>Size</b>	9"	9"	9"	7 3/4"	7 3/4"	7 3/4"	10 7/8"	10 7/8"	10 7/8"

Part Number	3930	3931	3932	3940	3941	3942	3950	3951	3970 / 3971
<b>Name</b>	White Wine Bottle (Clear)	White Wine Bottle (Brown)	White Wine Bottle (Green)	Red Wine Bottle (Clear)	Red Wine Bottle (Brown)	Red Wine Bottle (Green)	Coca-Cola Bottle (Traditional)	Medicine Bottle (Traditional)	Water Glasses (Short & Tall)
									
<b>Size</b>	11 1/2"	11 1/2"	11 1/2"	11 1/4"	11 1/4"	11 1/4"	7 3/4"	5 1/2"	3 1/4" / 5 1/4"

Sample Box available with one (1) of each: Brown Whiskey, Green Red Wine, Clear White Wine, Green Beer (Short Neck), Brown Beer (Long Neck), and Coca-Cola Bottle (Traditional).

**Please visit our website for important Breakaways shipping information.**

**800.230.9497 or 201.549.1160**

# Custom Manufacturing

City Theatrical has a beautiful 40,000 square foot manufacturing facility in Carlstadt, New Jersey, USA, just across the Hudson River from midtown Manhattan. Our factory is filled with computerized production machinery and skilled product developers, fabricators, and assemblers. Besides our catalog products, we presently produce a wide range of custom parts for designers and end users in the entertainment and architectural industries.



Our in-house capabilities include:

- Sheet metal fabrication, including:
  - High volume stamping
  - Fiber Laser
  - CNC punching
  - Bending
  - Welding
- Metal spinning
- Powder coating
- Electromechanical assembly and testing
- 3D mechanical design
- LED Tape cutting and soldering
- Custom low voltage dimmer boxes for indoor and outdoor LED tape projects



## Let us help solve your design challenges.

We offer fast turnaround production of custom parts and our City Theatrical guarantee of high quality with every order. Tell us more about your project and we will be happy to help come up with a custom solution to satisfy your project needs.

Submit your custom project requirements to:

[sales@citytheatrical.com](mailto:sales@citytheatrical.com)



Custom low voltage QolorFLEX  
Dimmer boxes

# CITY THEATRICAL

NEW YORK • LONDON

475 BARELL AVENUE, CARLSTADT, NJ 07072  
800.230.9497 OR 201.549.1160  
201.549.1161 FAX

OFFICE 31, UNITS 1-3, BEVERLEY WAY, NEW MALDEN,  
KT3 4PH UNITED KINGDOM  
+44 (0) 20 8949 5051

## OEM Manufacturing

Customized Technology for Lighting Manufacturers

Have you considered adding wireless DMX or RDM to some of your products, or just consolidating some of your supply chain issues and getting them under one roof rather than many? City Theatrical has grown to be an experienced manufacturer with a very knowledgeable staff and extensive esoteric lighting experience.

### Designed for OEM Partners

Multiverse Modules are best suited for lighting equipment manufacturers who are interested in adding wireless DMX to their products. Due to low cost, increased data transport, and ease of design integration, the Multiverse Module marks the first time that the implementation of a wireless DMX chip in every DMX device is possible.

Our custom OEM manufacturing capabilities include:

- Product design and development
- Software design including DMX and RDM
- Circuit design, development, and manufacturing (through-hole, SMT and mixed; all lead free)
- 3D mechanical design
- Automated wire cutting, stripping, and wire harness fabrication
- CE and ETL compliance
- Electromechanical assembly and testing
- Fast turnaround manufacturing
- Warehousing, packing, and shipping



Multiverse wireless DMX/RDM in ETC's fos/4 Panel

## Warranty

City Theatrical, Inc. warrants to the original purchaser that the equipment offered will be free from defects in workmanship and material for a period of one year from date of purchase. During the warranty period, units will be repaired or replaced at the option of City Theatrical, Inc.

The warranty does not extend to any parts of the unit that have been subjected to misuse or accident. Neither does the warranty cover any product that has been modified or repaired at other than an authorized repair station. The warranty will not apply if procedures described in any Operations Manual are not followed.

This warranty does not include shipping to or from City Theatrical. Unless otherwise stipulated by law, all warranties, expressed or implied, are limited to the period of this warranty.

Customers requiring repair of their equipment should obtain an RMA# from City Theatrical. Equipment should be suitably packaged, including a note with the owner's name and address and a description of the reason for return. Ship package prepaid and insured. City Theatrical cannot be responsible for loss or damage in shipment.

UNLESS EXCLUSIONS ARE SPECIFICALLY FORBIDDEN BY LAW, CITY THEATRICAL SHALL NOT BE LIABLE FOR INCIDENTAL OR CONSEQUENTIAL DAMAGES ARISING FROM THE USE OR FAILURE OF THIS PRODUCT, INCLUDING INJURY TO PERSONS OR PROPERTY.

© 2023 City Theatrical, Inc. All rights reserved.

800.230.9497 or 201.549.1160

