

MEGA
LITE[®]

Frostbot

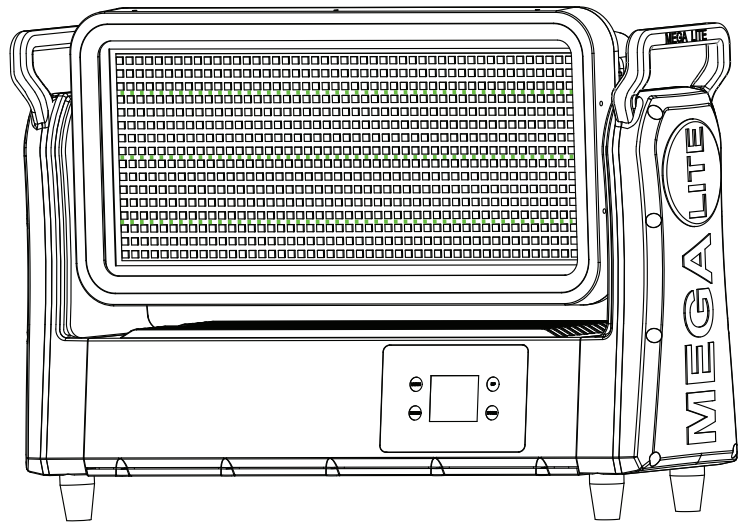

USER MANUAL

Table of Contents

Safety Information	2
What's Included	2
Specifications	3
Main Power Connection	4
DMX Connection	4
Display Settings	5
DMX Profile	7
Size And Weight	9
Installation	10
Parts and Accessories	11
Warranty	12
Customer Service	13

Check that the unit has not been damaged during transport.



Read all cautions and warnings
prior to operation of this
equipment

Protection Against Fire



1. Maintain a minimum of 1 foot distance from any type of flame.
2. Fixture is designed for indoor and outdoor use.
3. Do not install the unit too close to a heat source.
4. Make sure cables are properly secured.
5. Maximum surface operating temperature: 130°.
6. Make sure fixture lens are not pointing towards the sun or direct light input.

Protection Against Electrical Fire

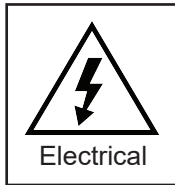

1. Disconnect power before servicing.
2. For connection to main power supply, proceed to page 4.
3. The power supply must be earthed (electronically grounded).
4. This fixture must not be left on for long periods of time.

Protection Against Mechanical Hazards

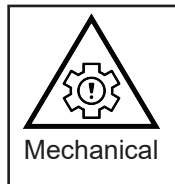

1. Use secondary safety chain when hanging unit.
2. Use quality clamps or bolts when positioning unit.
3. Do not open unit while it is on. Risk of electrical shock.

Ingress Protection

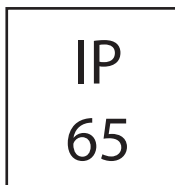

The IP rating is commonly expressed as IP (Ingress Protection) is followed by 2 numbers (i.e. 65) where the numbers define the fixture rating. The first number indicates the size of a particle that can enter the fixture.. The second number indicates the extent of protection against water entering the fixture. An IP65 rating in this fixture indicates that dust particles can not enter the fixture, and there is protection against water spray from entering the fixture from any direction.

What is Included

1pc Frostbot Fixture
1pc Power Cable - Nema 5-15 to SAC3FX-67
2pc Quick Release Mount
1pc User Manual

Specifications

Fixture ID 1189 - Frostbot

Mechanical Specifications

Housing:	Die-Cast Aluminum
Outdoor Rating:	IP-65
Mounting System:	2 Quick Release Clamp Mounts
Power Connection:	Input: Seetronics SAC3MPX-67 Output: Seetronics SAC3FPX-67-01 Cable Input: Nema 5-15 to SAC3FX-67 (cable included)
Signal Connection:	Input: Seetronics J5F2C-W-B-67 5 pin XLR Output: Seetronics K5F2C-W-B-67 5 pin XLR
Pan & Tilt:	Tilt 220°
Frost:	Frost Effect
Weight:	30.3lb
Size:	21" X 5.5" X 14"

Electrical Specifications

Light Source:	768 RGB 1.5W LEDs 144 White 2W LEDs
Power:	Electronic 100-240V AC 50/60
Power Consumption:	521 Watts 4.41 Amps @ 120V
Power Link:	3 Units @ 120V

Control & Programming

Protocol:	DMX 512, RDM
DMX Modes:	14 Channel Mode: Dimmer, Shutter, Strobe Rate, Duration, Tilt, Tiltfine, Tiltspeed, Frost, R,G,B,W1,W2,W3 18 Channel Mode: Dimmer, Shutter, Strobe Rate, Duration, Tilt, Tiltfine, Tiltspeed, Frost, R,G,B,W1,W2,W3, Color Macro, RGB Effect, White Effect, Effect Speed 76 Channel Mode: Tilt, Tiltfine, Shutter, Frost, R,G,B (x16) W1,W2,W3 (x24) 90 Channel Mode: Dimmer, Shutter, Strobe Rate, Duration, Tilt, Tiltfine, Tiltspeed, Frost, R,G,B,W1,W2,W3, Color Macro, RGB Effect, White Effect, Effect Speed, R,G,B (x15) W1,W2,W3 (x23)
RDM Parameters:	Fixture Label DMX Start Channel Address Channel Mode Set Temperature Sensor Keep DMX Data Scan Rate Dimmer Curve Fan Speed
Operating Mode:	DMX, Auto and Manual Settings Via Display

Main Power Connection

Caution!

1. Do not connect fixture to a dimmer system.
2. This unit must be earthed. (Electronically grounded)
3. Replace fuse only with the specified type and rating.
4. This device is equipped with auto switching power supply that will allow the fixture to work from 100-240V AC 50/60Hz
5. Power Link max 3 units at 120V

Cable USA	Cable EU	110V	220V
Black	Brown	Live	Live
White	Light Blue	Neutral	Live
Green	Yellow / Green	Ground	Ground

DMX-512 Connection

The fixture is equipped with 5 pin XLR Sockets for DMX input and output connection. The sockets are wired in parallel. Only use a shielded twisted pair cable designed for RS-485 and 5 pin XLR plugs and connectors in order to connect the controller with the fixture or the fixture with another.

DMX - Input

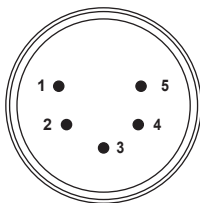

1. Shield (Grd)
2. Signal (-)
3. Signal (+)
4. N/A
5. N/A

DMX - Output

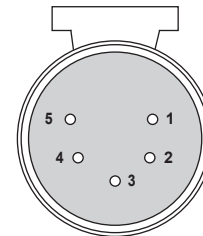

Caution!

On the last fixture the DMX signal needs to be terminated with a terminator. Pre-manufactured terminator are available for purchase from your Mega-Lite dealer item #P-DMX-T.

Display Control

Main Control

Use the onboard control interface to navigate through the menu options listed below. Each menu item contains configurable parameters designed to optimize and personalize the operation of your FrostBot:

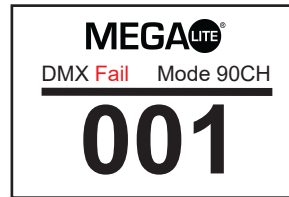

Address

- Setup
- Manual
- Calibration
- Reset
- Note

Main Menu: Use the UP / DOWN keys and ENTER / MENU keys to navigate through the settings.

Screen Lock Password: If screen lock is active, a blue box will appear on the screen next to the corresponding button. Press the menu keys with the adjacent flashing blue box in a sequence to unlock the screen.

DMX Address

001

No. 001, Offset 001

DMX Address: Set the starting DMX address using the UP and DOWN buttons.

System Setup

- Run Mode
- Channel
- RGB Inv Pix 1
- RGB Inv Pix 2
- W Inv Pixel
- Invert Tilt
- Encoder Crct
- Signal Keep
- Screen Saver
- Invert Screen
- Update Slave
- Language
- Dimmer Modes
- Dimmer Curve
- Fan Mode
- Screen Lock
- Load Default

- Run Mode:** DMX, Auto 1, Auto 2, Sound
- Channel:** 14CH, 18CH, 76CH, 90CH
- RGB Inv Pix 1:** Changes the direction of pixel effects. For instance, if the standard pixel effect moves from left to right, activating the Invert setting will make it move from right to left.
- RGB Inv Pix 2:** Changes the direction of pixel effects. Pixel effects divide between top and bottom when this setting is engaged.
- W Inv Pixel:** Changes the direction of the white segment pixel effects. Activating the Invert setting will make it move from right to left.
- Invert Tilt:** Users can invert or flip the tilt movement of the fixture.
- Encoder Correction:** Resets the fixtures tilt encoder.
- Signal Keep:** The fixture retains its current settings in the event of DMX signal interruption.
- Screen Saver:** This will black out the display screen when the menu functions are not in use.
- Invert Screen:** Allows users to reverse the direction of the fixtures menu screen.
- Update Slave:** When you activate the Auto mode on the initial light, subsequent lights connected in the same signal chain will mirror the same effect as the first light.
- Language:** EN, CN
- Dimmer Modes:** Allows users to adjust how the fixture responds to control signals in terms of dimming. By selecting different dimmer modes: **Stage, TV, Arch, Theatre, Stage 2**
- Dimmer Curve:** Allows users to adjust how the fixture responds to control signals in terms of dimming. By selecting different dimmer curves: **Square, Linear, S-Curve, Inverted Square**
- Fan Mode:** Auto / High / Low (The fixture's total output is decreased in this mode.)
- Screen Lock:** Prevent accidental changes to the settings or parameters of the fixture by locking the display screen.
- Load Default:** Restores the original factory settings of the fixture. By activating this feature, all customized configurations and adjustments made to the fixture will be reset to the default settings set by the manufacturer.

Manual Drive

1. Dimmer
2. Strobe
3. Rate
4. Duration
5. Tilt
-
-
-
85. White 19
86. White 20
87. White 21
88. White 22
89. White 23
90. White 24

Manual Mode: Adjustment of each channel from the Display. Use the Enter and UP/DOWN buttons to adjust the value of each channel manually to desired effect.

Calibration

Password: 0 0 0 0

Calibration: Password protected - Contact Manufacturer

Reset

Password: 0 0 0 0

Reset: Resets all motors, while maintaining all custom user settings. Password: 1234 (This is not a factory reset)

System Info

Reset Info >>
 DMX Data >>
 Sensor Info >>
 Hardware: 10.00.00.0
 SoftWare: 06.00.00.0

Reset Info: All detected system errors will be displayed here.
DMX Data: The display will show the DMX values being sent to the fixture.
Sensor Info: Displays the current hardware and software versions.

LED reference number for Pixel Mapping :

RGB LED Zones for Pixel Mapping

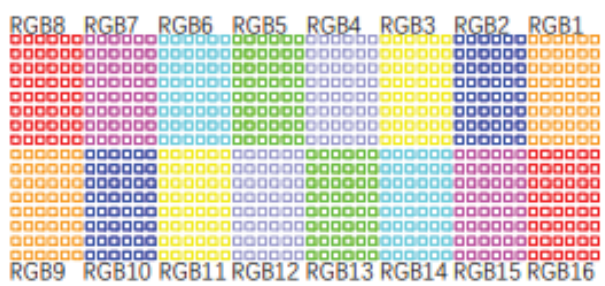

W LED Zones for Pixel Mapping



DMX Profile

Frostbot DMX Profile

14Ch Mode	18 Ch Mode	76 Ch Mode	90Ch Mode	Function	Description	Value	Init
1	1		1	Dimmer	Dimmer	0-255	255
2	2	3	2	Shutter	Open	000-002	2
					Strobe	003-005	0
					Ramp Up	006-050	0
					Ramp Down	051-100	0
					Lightning	151-200	0
					Random	201-255	0
3	3		3	Strobe Rate	Stroberate from slow to fast	0-255	0
4	4		4	Strobe Duration	Strobe Duration from slow to fast	0-255	0
5	5	1	5	Tilt	Tilt	0-255	128
6	6	2	6	Tiltfine	Tiltfine	0-255	0
7	7		7	Tilt Speed	Tilt speed	0-255	0
8	8	4	8	Frost	Frostr (Linear)	0-255	0
9	9		9	Red	Red (Full Panel)	0-255	255
10	10		10	Green	Green (Full Panel)	0-255	255
11	11		11	Blue	Blue (Full Panel)	0-255	255
12	12		12	White 1	White 1	0-255	0
13	13		13	White 2	White 2	0-255	0
14	14		14	White 2	White 3	0-255	0
	15		15	Color Preset	Color Preset	0-255	0
	16		16	RGB Macro	No Function	0-5	0
					RGB Effect 1	006-015	0
					RGB Effect 2	016-025	0
					RGB Effect 3	026-035	0
					RGB Effect 4	036-045	0
					RGB Effect 5	046-055	0
					RGB Effect 6	056-065	0
					RGB Effect 7	066-075	0
					RGB Effect 8	076-085	0
					RGB Effect 9	086-95	0
					RGB Effect 10	096-105	0
					RGB Effect 11	106-115	0
					RGB Effect 12	116-125	0
					RGB Effect 13	126-135	0
					RGB Effect 14	136-145	0
					RGB Effect 15	146-155	0
					RGB Effect 16	156-165	0
					RGB Effect 17	166-175	0
					RGB Effect 18	176-185	0
					RGB Effect 19	186-195	0
					RGB Effect 20	196-205	0
					RGB Effect 21	206-215	0
					RGB Effect 22	216-225	0
					RGB Effect 23	226-235	0
					RGB Effect 24	236-245	0
					RGB Effect 25	246-255	0
					No Function	0-3	0

DMX Profile

					White Effect 1	004-012	0
					White Effect 2	013-021	0
					White Effect 3	022-030	0
					White Effect 4	031-039	0
					White Effect 5	040-048	0
					White Effect 6	049-057	0
					White Effect 7	058-066	0
					White Effect 8	067-075	0
					White Effect 9	076-084	0
					White Effect 10	085-093	0
					White Effect 11	094-102	0
					White Effect 12	103-111	0
	17		17	White Macro	White Effect 13	112-120	0
					White Effect 14	121-129	0
					White Effect 15	130-138	0
					White Effect 16	139-147	0
					White Effect 17	148-156	0
					White Effect 18	157-165	0
					White Effect 19	166-174	0
					White Effect 20	175-183	0
					White Efect 21	184-192	0
					White Effect 22	193-201	0
					White Effect 23	202-210	0
					White Effect 24	211-219	0
					White Effect 25	220-228	0
					White Effect 26	229-237	0
					White Effect 27	238-246	0
					White Effect 28	247-255	0
	18		18	Macro Speed	Macro Effect Speed	0-255	0
		5	19	Red	Red 1	0-255	0
		6	20	Green	Green 1	0-255	0
		7	21	Blue	Blue 1	0-255	0
		"	"	"	" "	0-255	0
		"	"	"	" "	0-255	0
		"	"	"	" "	0-255	0
		50	64	Red	Red 16	0-255	0
		51	65	Green	Green 16	0-255	0
		52	66	Blue	Blue 16	0-255	0
		53	67	White	White 1	0-255	0
		54	68	White	White 2	0-255	0
		55	69	White	White 3	0-255	0
		"	"	"	" "	0-255	0
		"	"	"	" "	0-255	0
		"	"	"	" "	0-255	0
		74	88	White	White 22	0-255	0
		75	89	White	White 23	0-255	0
		76	90	White	White 24	0-255	0

Size and Weight

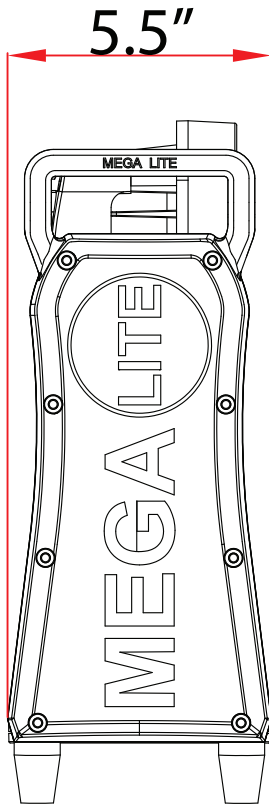
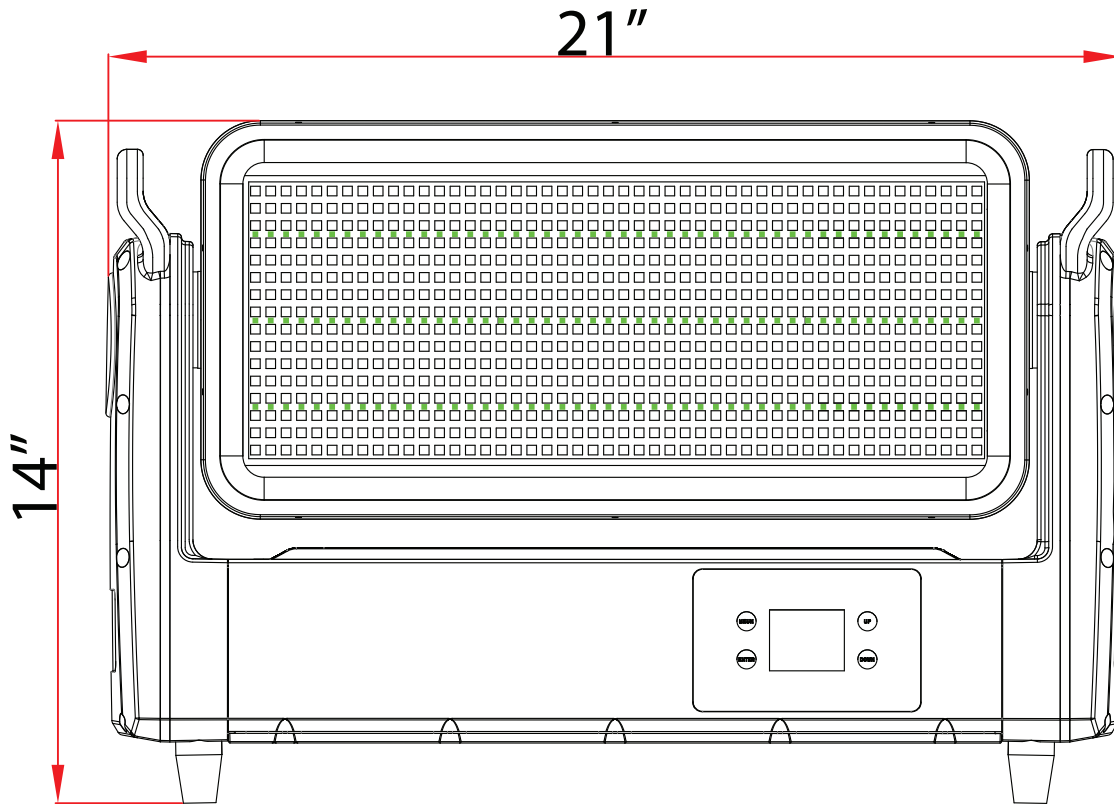

Fixture Size:	21" X 5.5" X 14"
Fixture Weight:	30.3lb
Packaged Size:	24" X 9" X 19"
Packaged Weight:	35.3lb

Installation

Caution!

1. The Installation must be carried out by an authorized dealer or trained professional.
2. Unit may cause severe injuries, if you have doubts concerning the safety do not install.
3. Unit is to be 24 inches away from flammable materials.
4. Use high quality installation equipment to hang the unit.

When rigging the it is very important that you follow common safety procedures. Rigging requires extensive experience including but not limited to calculating working weight loads, material being used and periodic safety inspections. If you lack these qualifications, do not attempt the installation yourself, instead use a professional structural rigger.

When rigging the unit always be secure with a secondary safety attachment. The installation location of the fixture has got to be built in the way that it can hold 10 times the weight for 1 hour with out any failures. Installation should be checked at least one time a year by a skilled professional.

Parts & Accessories

Part Number	Description	
1189-LED-RGB	5050 1.5W RGB LED	
1189-LED-WHI	3030 2W White LED	
1189-LED-MOD	Complete LED Board	1.
1189-PCB-DIS	Frostbot Display PCB	2.
1189-POW	Frostbot Power Supply	3.
1189-HOU-BOD	Frostbot Aluminum Body	4.
1189-HOU-ARM	Frostbot Aluminum Arm	5.
1189-CON-3PI	IP 3 Pin XLR (Male & Female)	
1189-FAN	Frostbot IP Rated Fan	6.
1189-SEN-GUI	Frostbot Guide Sensor	7.
1189-SEN-MOT	Frostbot Motor Tilt Sensor	8.
1189-BAN-TIL	Frostbot Tilt Band	9.
1189-MOT	Frostbot Tilt Motor	10.
1189-GLA	Front Electronic Glass	11.
1189-HOU-QUI	Quick Connect Clamp (Set of 2)	
1189-CON-5PI	IP 5 Pin XLR (Male & Female)	12.
1189-CON-POW	Power Connection (Male & Female)	13.

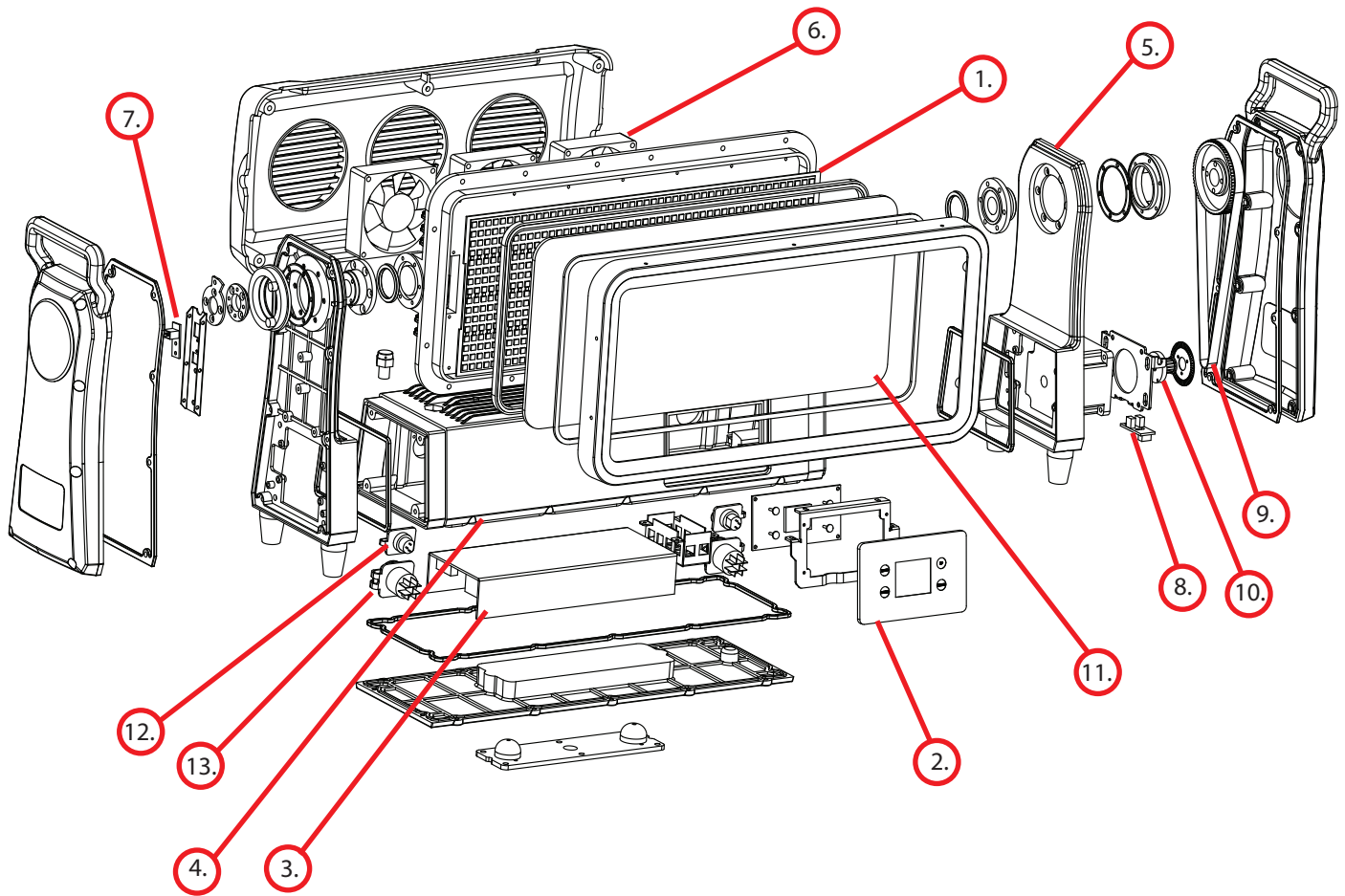

General Terms & Conditions

1. All resellers must have approved and signed Reseller Application on file, including their respective state tax information and W-9. Applications are re-evaluated on a fiscal calendar year basis to assure business integrity and tax status.
2. Cash, check, cashiers check, ACH, wire transfer, MasterCard, Visa, Discover, and American Express are accepted forms of payment.
3. Past due invoices will be charged 1.5% per month finance charge. Uncollected invoices are subject to be turned over to collection.
4. The reseller will pay all reasonable expenses incurred in the course of collections.
5. The proper venue for litigation will be Bexar County, Texas.
6. Returned checks will be charged a \$50.00 fee.
7. All prices are in U.S. Dollars.
8. All prices and specifications are subject to change without notice, sales order confirmations are emailed and will reflect correct pricing.
9. All terms are insured, monitored, analyzed and approved by Coface USA. Changes in credit line and approved terms can change without notice. Company authorization of credit is based on Coface approvals. Any conflicts or disagreements should be referred to: 650 College Rd East Suite 2005 Princeton, NJ 08540. 1-609-469-0400. E-mail: cofaceusa@coface.com
10. Returns are subject to 25% restocking charge plus any necessary charges for repair or re-packaging.

Shipping Terms & Conditions

1. All orders are EXW San Antonio, TX (EXW means that a buyer/reseller incurs the risks for bringing the goods to their final destination) any deviation needs to be done in writing.
2. UPS ground shipping is the preferred shipping method. Requests for specific carriers may require use of the customer's account number and may incur an additional charge for handling.
3. Drop shipments are subject to all return charges at resellers expense. Drop shipments are not allowed outside of the territorial United States.
4. NO C.O.D. shipments allowed.
5. Returned and undelivered shipment charges are the buyer/resellers responsibility and will be billed to the buyer/reseller.
6. The freight carrier and Company shipping@mega.lighting should be notified upon receipt of damaged freight, discrepancies, or non-conformities within 24 hours. Company can assist in making claims with carriers or agents in the event of any loss or damage.
7. Upon acceptance in good order by Carrier from Company, the material becomes the property of the Reseller.

Warranty and Service Procedures

1. All returns require an RMA# (Return Merchandise Authorization number) before returning goods for any reason. For a service or warranty RMA, please email service@mega.lighting or call (210)684-2600. For sales or demo returns, please contact sales@mega.lighting.
2. Case will be created and an RMA notice will be emailed. All units received must have the RMA # included with the unit as well as on the shipping label.
3. All shipping charges are the responsibility of the customer: MEGA Systems, Inc., Service, 18668 HWY 16 N., Helotes, TX 78023

Warranty for Products Purchased Before 2021

Unless otherwise stated in writing, product is covered by a one year parts and labor limited warranty and is subject to same limitations listed under the limited warranty exclusions listed below.

Warranty for Products Purchased After January 1, 2021

MEGA SYSTEMS INC ("MSI") hereby warrants to the original purchaser/owner (Customer"), MSI products to be free of manufacturing defects in material and workmanship, for the warranty periods as defined below from the original purchase invoice date. This warranty applies exclusively to new MSI branded and/or distributed products listed below, purchased from an MSI AUTHORIZED dealer/reseller. This warranty is not transferrable and may or may not apply to products sold and/or forwarded outside the United States. Please contact MSI for applicable regional product warranty information.

The purchase of MSI product constitutes the Customer's acceptance of all warranty terms and conditions as listed in this limited warranty statement. This warranty provides the Customer with legal rights, which may vary from state to state. Please contact MSI regarding warranty questions prior to purchasing.

Product / Series	Warranty Period	Coverage
Battery Powered LED	Six month battery, one year all other components	1, 2
Moving LED, Hazers	One Year	2
Outdoor IP-Rated LED	Two Years	3
House Light LED, Decorative LED, Compact LED, iCandy LED, Theatrical LED, Strobe Wash LED, Follow Spot LED, Production & House of Worship Control, Architectural Control, Theatrical Control, Dance Venue & Mobile DJ Control, Direct View LED Displays, and MV Controllers	Three Years	4

1. Battery: 183 days/six months 2. Parts and Labor: 365 days/one year 3. Parts and Labor: 730 days/two years 4. Parts and Labor: 1095 days/three years

This limited warranty excludes any defects caused by, resulting from, or relating to the following:

- Normal wear and tear of lamps, color media, brushes, contact rings, lamp sockets, belts and other parts prone to wear and tear.
- Misuse, abuse, improper handling, accident, alteration or attempts to repair by or on behalf of the owner or any person not authorized by MSI.
- Damage to the product resulting from acts of God, including but not limited to, earthquakes, hurricanes, tornadoes, lightning and other natural disasters, fire, explosion, flood, riots, civil disorder or any other cause beyond the reasonable control of MSI.
- Exposure to harsh or excessively corrosive environmental conditions (whether indoors or outdoors) including, but not limited to, extreme temperature, humidity, atmospheric conditions (including salinity or pressure), radiation (UV, infrared or nuclear), shock and conditions which exceed the product's Ingress Protection ("IP") rating.
- Use of the product in a manner which exceeds the applicable product specification, including, but not limited to, exposure to excessive, insufficient, or other voltage conditions.
- Installation or use of the product not in accordance with the technical documentation, MSI guidelines (as may be posted on its website at www.megasystemsinc.com from time to time or otherwise designated by MSI or its brands) or applicable building and electrical codes, regulations, and standards.
- Failure to maintain the product in accordance with the technical documentation.
- Natural degradation and color shift of the LED source over the course of normal product use.
- Slight deviations in the specified values of intensity and color that do not affect the functionality of the product.
- Use of the product not for its intended purpose.

All warranty claims are evaluated under the terms of this limited warranty. If a product falls within the warranty period and if, upon examination by MSI, it is found to have failed for a covered cause, MSI will, at its sole discretion, repair or replace the defective part or product or reimburse the purchaser a pro-rated portion of the purchase price based on the percentage of the warranty period still remaining as of the date that the returned product was received by MSI. Should a replacement part or product be discontinued or unavailable, MSI reserves the right, in its sole and absolute discretion, to substitute a comparable replacement part or product for the defective part of product. MSI warranty obligation herunder is limited solely to the repair or replacement of or reimbursement for the particular parts or products determined by MSI to have failed for a covered cause within the warranty period. In no event shall MSI be responsible to replace or reimburse purchaser for any products or portions of a system that MSI determines has not failed for a covered cause within the warranty period, even if such other products or portions of a system are used together with products being repaired or replaced by MSI under this warranty and the repaired product differs in brightness, colors or any other attribute after the repair.

Costs of removal, shipping to MSI or its authorized representative and reinstallation are solely the responsibility of the purchaser. If MSI determines that the product is covered by this limited warranty, it will only pay for parts and labor as indicated by product type. If MSI determines that the product is not covered by this limited warranty, the purchaser will have the option of paying for the repair if the product can be repaired and the purchaser shall be responsible for the cost of shipping the repaired product back to the purchaser. MSI reserves the right, in its sole and absolute discretion, to decline any repair.

IN NO EVENT SHALL MEGA SYSTEMS, INC. BE LIABLE FOR ANY INCIDENTAL, CONSEQUENTIAL, SPECIAL, INDIRECT OR PUNITIVE LOSS OR DAMAGE OF ANY KIND, INCLUDING, BUT NOT LIMITED TO, LOSS OF PROFITS OR REVENUES, LOSS OF USE OF THE PRODUCT OR ANY OTHER GOODS OR ASSOCIATED EQUIPMENT, DAMAGE TO ANY ASSOCIATED EQUIPMENT, COST OF CAPITAL, COST OF SUBSTITUTE PRODUCTS, FACILITIES OR SERVICES, DOWN TIME COST, INSTALLATION OR LABOR COSTS, OR CLAIMS OF THE PURCHASER'S CUSTOMERS, WHETHER BASED ON WARRANTY, CONTRACT OR NEGLIGENCE, ARISING IN CONNECTION WITH THE SALE, USE OR REPAIR OF THE PRODUCT. MEGA SYSTEMS INC'S MAXIMUM LIABILITY SHALL NOT, IN ANY CASE, EXCEED THE PURCHASE PRICE OF THE PRODUCT THAT GIVES RISE TO THE CLAIM.

EXCEPT FOR THE LIMITED WARRANTY SET FORTH HEREIN, ALL PRODUCTS SOLD BY MEGA SYSTEMS, INC. ARE SOLD "AS IS" WITHOUT ANY WARRANTY, EXPRESS, OR IMPLIED, STATUTORY OR OTHERWISE, INCLUDING, BUT NOT LIMITED TO, IMPLIED WARRANTIES OR MERCHANTABILITY AND FITNESS FOR A PARTICULAR PURPOSE, ALL OF WHICH ARE EXPRESSLY AND SPECIFICALLY DISCLAIMED BY MEGA SYSTEMS, INC.

Customer Support

MEGA-Lite has a customer support line to provide set-up help and to answer any questions should you encounter a problem. Please visit our website for any other related technical documents. For service related issues, please contact our service dept.

Monday - Friday 9am to 6pm CST
(210)684-2600
Service@mega.lighting

Manual Version

Please visit www.mega.lighting for the most up-to-date manual version.

Manual Version	Date	Fixture Software	Notes
1.0	08/15/2025	1.0.0	



MEGA LITE
18662 Bandera Rd
Helotes, TX 78023
Phone (210)684-2600 / Fax (210)855-6279
www.mega.lighting / info@mega.lighting