

FOLLOWBOT¹⁵⁰⁰LED

Product Description:

FOLLOWBOT 1500 LED is driven by a 1500w LED Light engine, making this a very bright followspot. Ideal for long through 200 feet or more. It is a manually controlled unit that incorporates a manual zoom and focus. Two rotary knobs allow for manual control of the motorised Frost and beam softener (frost). A control panel on the side allows precise dimming or dousing of the lamp as needed, which can also be controlled via DMX (when connected), enabling external control of intensity, strobe, and blackouts from any DMX controller. It includes a Gobo or color filter slot to provide the desired set color filter or use a high-temp gobo to project your gobo like never before. The front bezel allows mounting the color carousel, so you can add your desired colors or filters to your performance. The unit ships with its heavy-duty tripod and is packaged in the included case.



Lamp:	Led1500W
Color temperature:	7500K
Lifetime of LED:	more than 20000hours
Luminous flux:	85500-95000LM
Focus and zoom:	Manual
Adjustable beam angle:	Long throw 3.5°-10°
Heat dissipation:	high-quality radiator, low-noise fan
Dimmer:	smooth electronic 0-100% linear dimmer
Strobe:	1-20 flashes per second
Softing wheel:	Manual control knobe of motorised frost/edge softener
Iris:	Manual control knobe of motorised Iris
Boomerang:	Manual adjustment, 6 slots
GOBO holder:	for gobos and color dicroc filters
Control mode:	DMX512 signal, with XLR 5PIN in and out to connect to DMX controller (dimmer/dowser and strobe control only)

Mechanical Specifications

Housing:	Extruded aluminum, Plastic Bezel
Mounting System:	Stand Mount (stand included)
Power Connection:	Seetronics SAC3FX-BKB Connection to Nema 5-15 Connection Cable
Signal Connection:	5 Pin XLR In and Out
Dimmer:	Electronic 0-100% linear dimmer
Focus:	Manual Focus
Zoom:	Manual 3.5° to 10° Zoom
Iris:	Electronic Iris
Soft Wheel:	Electronics Adjust light to deep
Static Gobos:	1 removable gobo slot (non-rotational)
Boomerang:	Manual adjustment, 6 slots

Electrical Specifications

Light Source:	1 X 1500W LED
Lumens @ Full:	11703 - 15471Lm
Color Temp:	7500K
CRI:	Narrow 70.5 Wide 70
Power Supply:	Electronic 100-240V AC 50/60
Power Consumption:	1486 Watts 13.5 Amps @110V

Control System

Protocol:	DMX 512
Channel Modes:	3 Modes of operation 1 Channel 2 Channel 4 Channel
Display:	Oled Display

Size and Weight

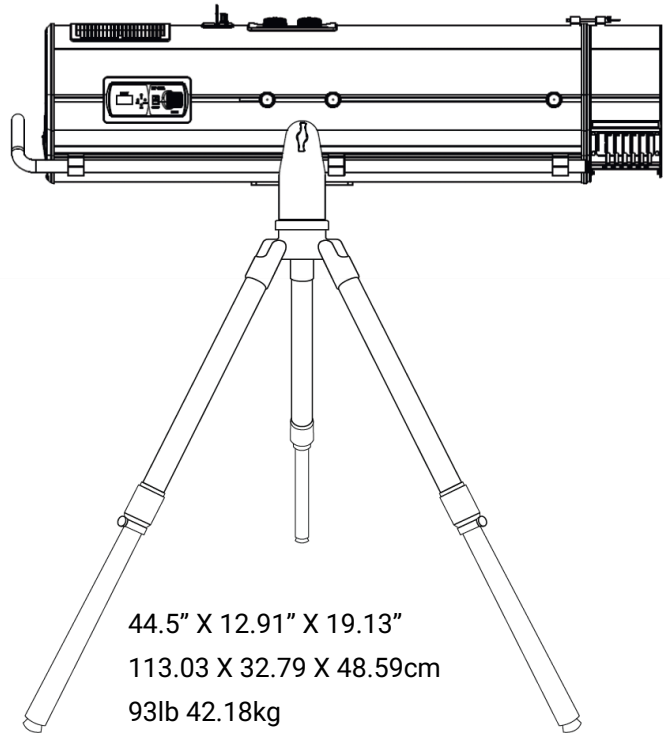
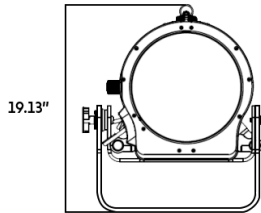
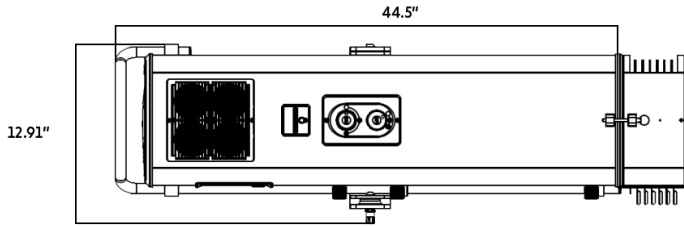

Fixture Size:

Fixture Weight:

Packaged Size:

Packaged Weight:

44.5" X 12.91" X 19.13"

113.03 X 32.79 X 48.59cm

93lb 42.18kg

49.5" X 18.5" X 23"

125.73 X 46.99 X 58.42cm

98lb 44.45kg

Included Items

FOLLOWBOT 1500W LED
Boomerang
Power cable
Manual

7075

Accessories

Road Case
Stand

CAS-7075-1-B

Customer Service

MEGA-Lite has a customer support line to provide set-up help and answer any questions should you encounter a problem. Please visit our website for any other related technical documents. For service-related issues, please contact our service department at service@mega.lighting

Operating Hours: Monday - Friday 9AM - 6PM CST

Phone:(210) 684-2600

Email:Sales@mega.lighting

MEGA LITE[®]

18662 Bandera Rd
Helotes, TX 78023

Phone (210)684-2600 / Fax (210)855-6279 www.mega.lighting / info@mega.lighting