



**e 614**

**Instruction manual**



## Delivery includes

- e 614
- MZQ 100 microphone clamp
- pouch
- quick guide
- safety guide

## Product overview

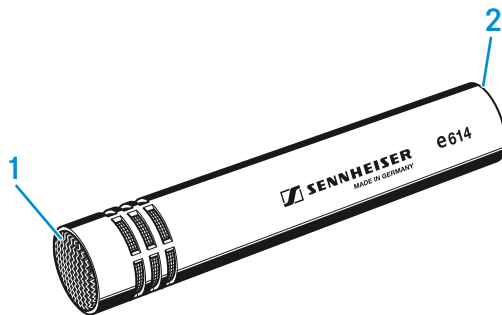

1. Sound inlet basket
2. XLR-3 connector



## Installation

### Attaching the microphone

- ▷ Screw the microphone clamp to a stand.
- ▷ Place the microphone with its back end into the microphone clamp.
- ▷ Orient the microphone together with the microphone clamp.

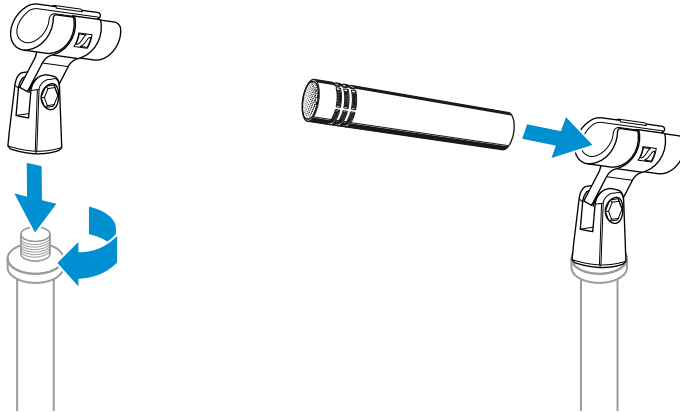

### Connecting the microphone

- ▷ Connect the XLR-3 socket of the microphone cable (optional accessories) to the XLR-3 socket of the microphone.

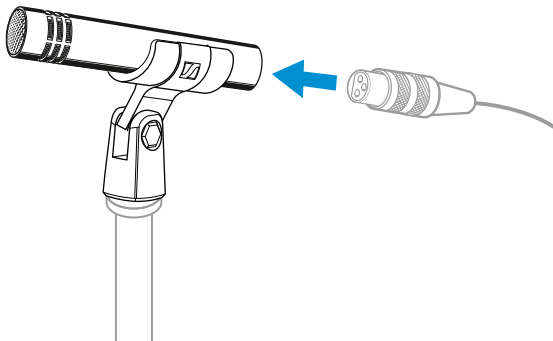

### Using the windshield

- ▷ Place the MZW 64 (optional accessories) windshield over the microphone head.

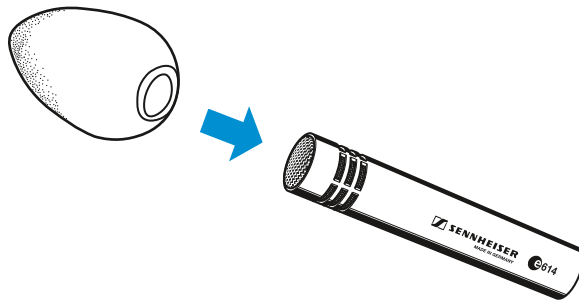



## Operation

### Positioning the microphone: Drums / Percussions

**Attention:** When closing the hi-hat, a strong air current is created on the edge. If the microphone is positioned too close to the edge, interfering noise due to the air current can occur.

▷ It is vital to observe the following notes:

Position	Resulting sound	Commentary
A	Natural, clear sound	Position the microphone a few centimetres above the outer edge of the hi-hat aiming down. If necessary, remove unwanted low-frequency signal portions by high pass filtering.
B	More fundamental, little overtones	

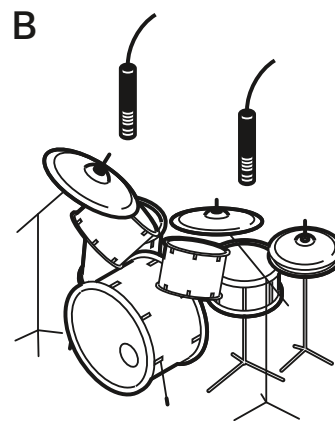
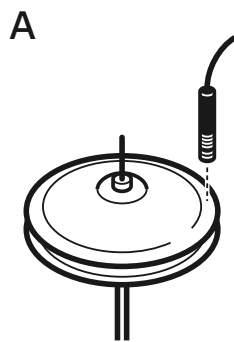

### Positioning the monitor loudspeakers

▷ To prevent feedback and crosstalk, position your monitor loudspeakers in the angle area of the highest cancellation of the microphone (approx. 135°).

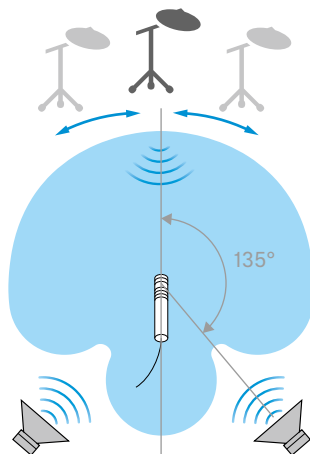



## Cleaning and maintaining the e 614

---

### CAUTION

#### LIQUIDS CAN DAMAGE THE ELECTRONICS OF THE PRODUCT!

Liquids entering the housing of the product can cause a short-circuit and damage the electronics.

- ▷ Keep all liquids away from the product.
  - ▷ Do not use any solvents or cleansing agents.
- 
- ▷ Disconnect the products from the power supply system and remove rechargeable batteries and batteries before you begin cleaning.
  - ▷ Clean all products only with a soft, dry cloth.

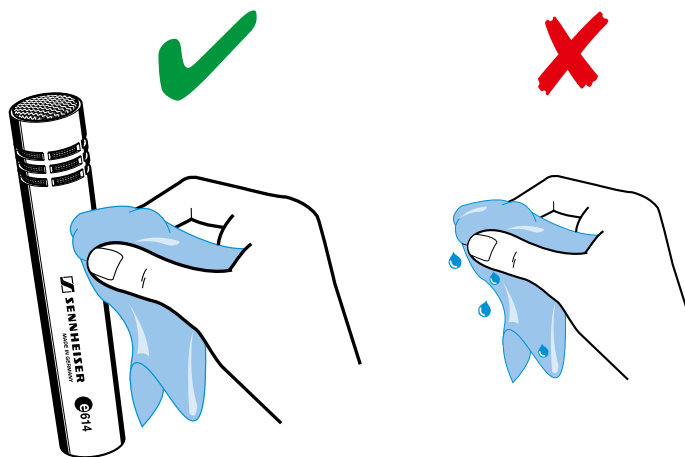



## Specifications

Transducer principle	pre-polarised condenser microphone
Frequency response	40 - 20,000 Hz
Pick-up pattern	super-cardioid
Sensitivity (free field, no load)	3 mV/Pa
Nominal impedance (at 1 kHz)	50 $\Omega$
Min. terminating impedance	1 k $\Omega$
Max. sound pressure level (at 1 kHz)	139 dB
Equivalent noise level	
A-weighted	24 dB(A)
CCIR-weighted	35 dB
Phantom powering	12 - 48 V
Connector	XLR-3
Dimensions	$\varnothing$ 20 x 100 mm
Weight	73 g

### Polar pattern

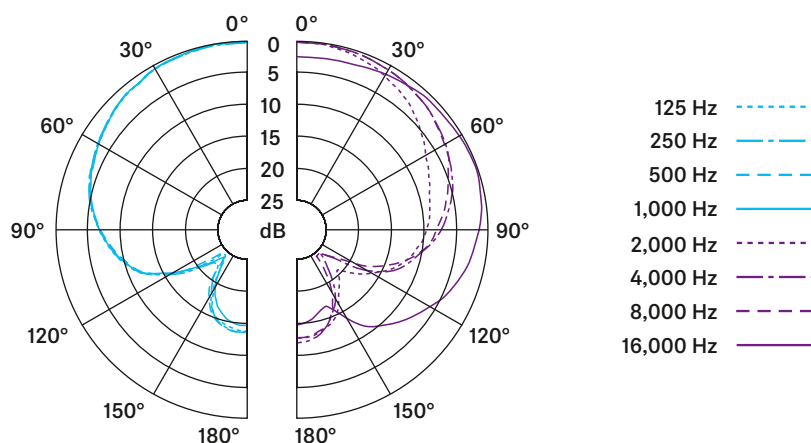

### Frequency response

