

WP-700-EB

Remote Control Panel



The WP-700 is a remote control switch/volume panel that is designed for use with the MA-725F amplifiers to enable remote selection of input source and adjusting volume level through Ethernet cable connection to the MA-725F.

Key features

- A remote control switch/volume panel designed to be used with the MA-725F amplifier.
- Provides remote select input source and adjusts volume levels through an Ethernet cable
- It can be mounted in a 1-gang electrical box

Specifications

Control	Input select switch x 1, Volume control knob x 1
Cable Requirements	CAT 5 / 5e / 6 STP cable
Terminal	RJ 45 connector
Finish	Surface treated steel plate, white paint (RAL 9016)
Dimensions	72 (W) x 128 (H) x 56.6 (D) mm
Weight	188g

Dimensions

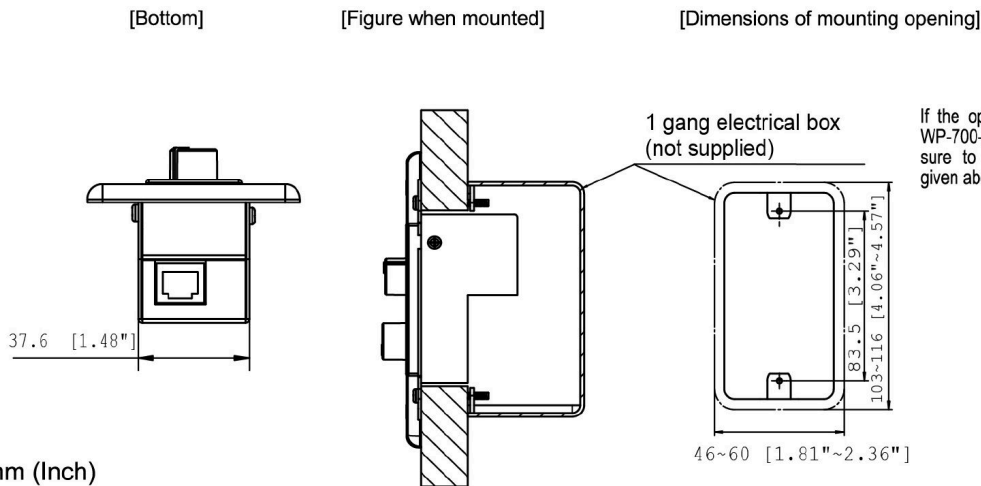
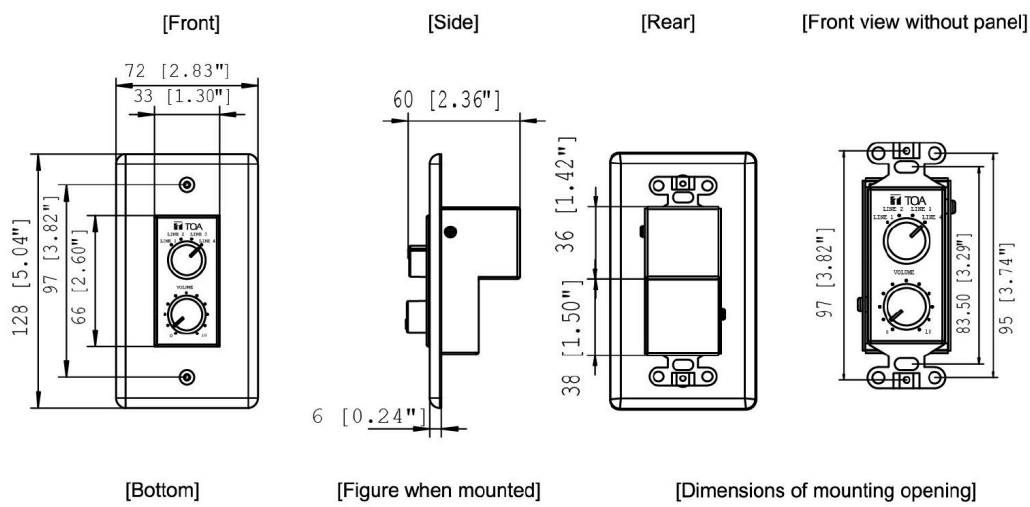

If the opening is too small or too large, the WP-700-AS cannot be mounted in the wall. Be sure to make an opening with dimensions given above when mounting.

Unit: mm (Inch)