

MODEL: TAMBORA RAYS

CODE: CL2025

December 5, 2024

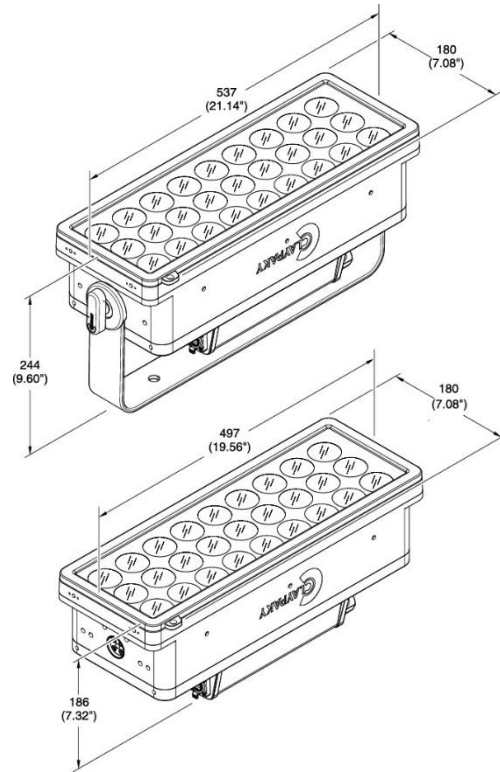

LIGHT SOURCE:

Source type: • 27 LEDs RGBWW x 40W

CRI: • Up to 80

LED life expectancy: • 50.000 Hrs L70*

* It may vary depending on various factors, such as the type of use and environment

PHOTOMETRIC DATA:

Lm output: • 23702 Lm (integrating sphere)

Beam angle • Beam: • 13.7°: 10%
• 7.1°: 50%

Optical syt.: • High efficiency

NOISE LEVEL:

Controlled by: • Able to control linearly the speed of the fans

Fixed presets: • Auto: 46.3 dB
• Silent: 32.5 dB
• Theatre: 32.2 dB
• Constant: 51.4 dB

CONTROL & CONNECTIONS:

Personalities: • Main engine: 3 modes with 10 / 32 / 26 control channels
• Pixels engine: 2 modes with 81 / 108 control channels

Protocols: • DMX, Art-Net, sACN, RDM, Webserver

Connectors: • Locking 5 pin XLR IN/OUT
• RJ45 IN/OUT

Power con.: • PowerCon True1 IN/OUT

Web server: • Built-in

CloudIO: • Fully compatible

DYNAMIC EFFECTS:

Colors: • Advanced layers management (color, internal shape, pixel mapping (3 x 9))
• Linear CTO2700K to 8000K
• Individual control of all 27 LEDs
• Pre-programmed shape selection of static and dynamic patterns, adjustable in color, speed, direction, fade and strobe

Strobe: • Electronic strobe from 1 to 30 f/sec

**Dimmer /
Shutter:**

- High resolution electronic dimmer - 16 bit, 5 curves

- 2009/125/EC - EcoDesign requirements for Energy-related Products (ErP)

HARDWARE & SOFTWARE:

- Long life self-charging battery
- Display graphic LCD backlit B/W display
- Firmware upload from another fixture
- Firmware upgrade via Web Server
- Diagnostic
- DMX monitoring
- Remote access through RDM

HOUSING:

- Magnesium housing
- IP66 protection rate
- Working in any position
- Advanced mechanics for horizontal and vertical combination
- Hanging system: with fast-lock Omega clamps (1/4) turn on the base
- Optional safety chain

ELECTRICAL:**Operating**

- voltage:** • 100-240V, 50/60 Hz

- Power Supply:** • Electronic auto range with active PFC

- MAX power consumption:** • 720 W

THERMAL SPECIFICATION:

- MAX Ambient temperature:** • 45°C (113°F)

- Min Ambient Temperature:** • -20°C (-4°F)

- MAX temp. of the ext. surface:** • 90°C (194°F)

- Total heat dissipation:** • 2460 BTU/hr ±10% / 2592 kJ/hr ±10%

SAFETY SPECIFICATIONS:

- Min. dist. of illum. objs:** • 0,5 m (1'8")

- Min. dist. from flamm. mat.:** • 0,2 m (8")

- Protections:**
- Thermally protected power supply (overheating and cooling failure)
 - Forced ventilation with axial fans
 - External mains fuse T 10A 250V
 - External fuse for battery T 3A 250V

COMPLIANCE:**CE Marking (in conformity to the following):**

- 2014/35/EU – Safety of electrical equipment supplied at low voltage (LVD)
- 2014/30/EU – Electromagnetic compatibility of equipment (EMC)
- 2011/65/EU - Restriction of the use of certain hazardous substances (RoHS)

UKCA conforms to UK regulations:

- S.I. 2016 N. 1101
- S.I. 2016 N. 1091
- S.I. 2012 N. 3032
- S.I. 2021 N. 745

cMETus LISTED:

- UL 1573:2003
- CSA C22.2 N.166:2015

PACKAGING:

- Carton box + Foam shell
- Carton box + Polystyrene
- Flight case + Foam shell

WEIGHT & SIZES:

- Weight:** • 10,44 Kg (23.02 lbs)

- Dim.s without handle:** • 497 x 180 x 186 mm
• 19.56 x 7.08 x 7.32 In

- Dim.s with handle:** • 537 x 180 x 244 mm
• 21.14 x 7.08 x 9,61 In

ACCESSORIES:

- Omega bracket:** • 183102/805 (Included)

- ETL Power:** • CAB02B/802 (Optional)*
* Cord 1.5 m (bare end with IP65 PowerConTrue1 conn.)

- Aliscaf holder:** • CA3031000102 (Optional)

- Connecting bracket kit:** • CA3038000102 (Optional)

- Gr.d stander:** • CA3042000102 (Optional)

- Inc. gr.d. syt.:** • CA3043000102 (Optional)

- Str. gr.d syt.:** • CA3044000102 (Optional)

- Barndoor:** • CA3064000102 (Optional)

- Top hat:** • CA3065000102 (Optional)

- Foam shell:** • F21334/001 (Optional)

- Flight case (4 pos):** • CF1020F (Optional)

- Safety Chain:** • 105041/003 (Optional)

- Frost filters: (Optional)**
- 10°: CA3054000102
 - 15°: CA3055000102
 - 20°: CA3056000102
 - 30°: CA3057000102
 - 40°: CA3058000102
 - 50°: CA3059000102
 - 80°: CA3060000102
 - Neutral: CA3061000102
 - 60° x 10°: CA3062000102
 - 10° x 60°: CA3063000102