

# MIPRO®

TA-80 Rechargeable Digital Wireless  
Plug-on Transmitter

User Guide

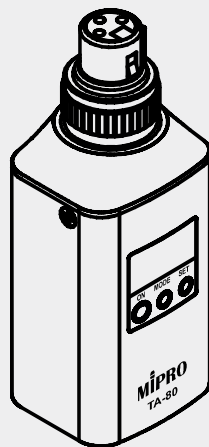



I. Part Names, Fig. 1

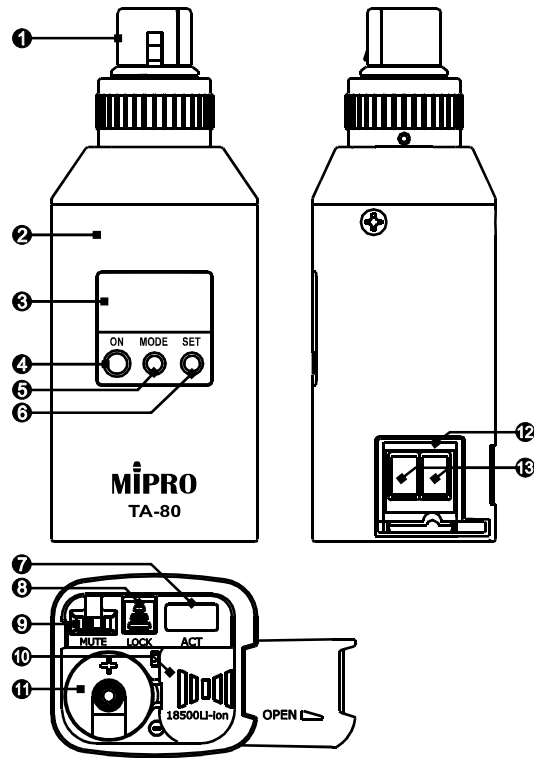

Fig. 1

- ❶ XLR Socket.
- ❷ Housing.
- ❸ LCD Screen.
- ❹ Power Button.

- ⑤ MODE Button.
- ⑥ SET Button.
- ⑦ ACT Sync Port.
- ⑧ Battery Cover Lock.
- ⑨ Mute Switch.
- ⑩ Battery Cover.
- ⑪ Battery Compartment.
- ⑫ Charge Contacts Holder.
- ⑬ Charge Contacts.

## II. LCD Screen Display, Fig. 2

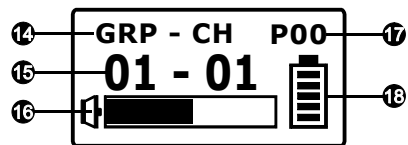

Fig. 2

- 14 Settings.
- 15 Parameters.
- 16 AF (audio) Meter.
- 17 Phantom Power Status.
- 18 Transmitter Battery Meter.

### III. Operating Instructions

1. Ascertain a wired microphone is plugged-in prior to power on the transmitter to prevent noise interference.
2. Tighten the mechanical locking ring in a clockwise direction for a secured fit, Fig. 3.
3. Unplug the microphone in a counter-clockwise direction.
4. XLR balanced microphone connection pin name and function.
  - (A) Pin 1: Ground Pin.  
(Negative phantom power)
  - (B) Pin 2: AF+ (HOT) Positive phase input pin.  
(String 6.8K $\Omega$  resistance to positive phantom power)
  - (C) Pin 3: AF-(COOL) Negative phase input pin.  
(String 6.8K $\Omega$  resistance to positive phantom power)

Rechargeable Digital Wireless Plug-on Transmitter

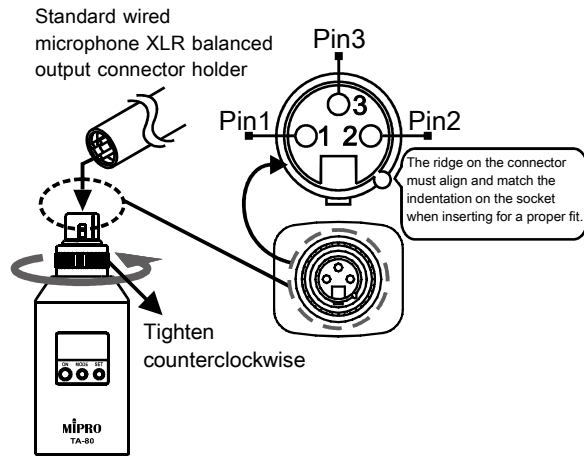

Fig. 3

#### IV. How to Setup Transmitter Parameters

1. MODE Button: Press "MODE" button to access one of the functions below.
2. SET Button: Press "SET" button and LCD will start flashing. During flashing, press SET button to change parameters.

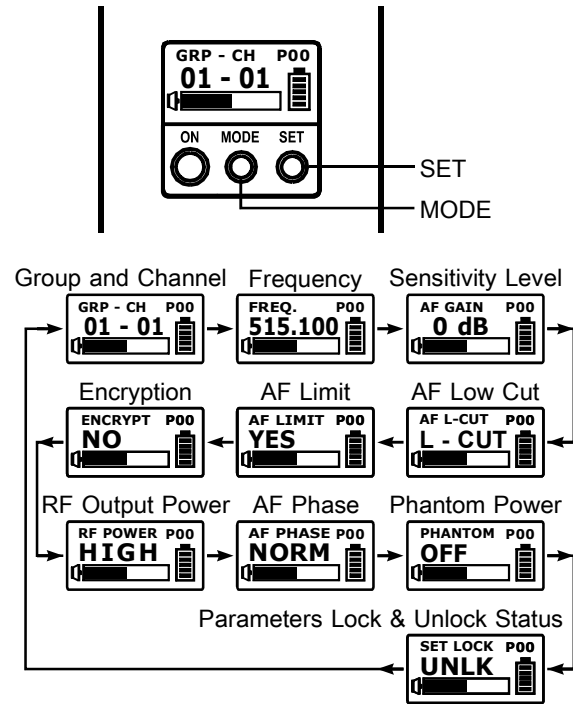

Fig. 4



3. GRP-CH: Displays Group and Channel Information, Fig. 5.

- (A) Press MODE and stop on the GRP CH function; the LCD screen will start flashing in the current set state. After 30 seconds, the display will stop flashing and show the current group and channel.
- (B) The group and channel information is now shown on the display. Changing the current group and channel must be done on the receiver.
- (C) Programming and saving Group and Channel need to be synced by pressing "ACT" button on the receiver.
- (D) When programming a special frequency via monitoring software, the LCD screen cannot display the number. This is because this special channel is not in the preset group and channel. RF, the LCD panel will look like the illustration below.

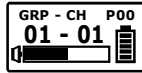

Fig. 5

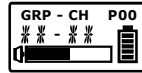

Fig. 6

4. **FREQUENCY: Displays Transmitter Frequency Information, Fig. 7.**
- (A) Press MODE and stop on the FREQUENCY function; the LCD screen will start flashing in the current set state.
  - (B) The screen will stop flashing and remain in the set state if not operated within 30 seconds.
  - (C) Changing the current frequency must be done on the receiver.
  - (D) Programming and saving Frequency need to be synced by pressing "ACT" button on the receiver.

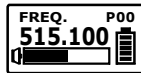

Fig. 7

5. AF GAIN: Setup and Change of Input Sensitivity, Fig. 8.

- (A) AF gain -18dB ~ 30dB in 6dB increment.
- (B) Press MODE and stop on the AF GAIN function; the LCD screen will start flashing in the current set state and is ready for change.
- (C) Press SET button to set dB value. -18dB ~ 30dB in 6dB increment.
- (D) The screen will stop flashing and remain in the set state if not operated within 30 seconds.
- (E) The higher the gains are set, the lower the dynamic range for signal input and the greater the danger of unwanted noises and feedback getting into the system.
- (F) When the gain set at 0dB, the maximum input strength is 2 Vrms (6dBV).
- (G) When the gain is set at -12dB or -18dB it stands up to 20Vp-p input signals. Signals cut off when it exceeds this level.

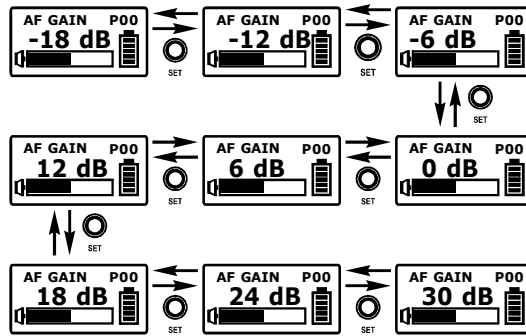

Fig. 8

6. AF L-CUT: Setup and Change of Low Frequency Cut Off, Fig. 9.

- (A) Press MODE and stop on the AF L-CUT function; the LCD screen will start flashing in the current set state and is ready for change.
- (B) Press the SET button while the display is flashing to change to L- CUT or FLAT as desired.
- (C) The screen will stop flashing and remain in the set state if not operated within 30 seconds.
- (D) When the AF L-CUT function is LOW CUT, the frequency response below 100Hz will decrease about 3dB with a slope of -6dB/Octave.

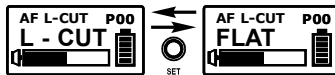

Fig. 9

7. AF LIMIT: Setup and Change of Input Limit, Fig. 10.

- (A) Press MODE and stop on the AF LIMIT function; the LCD screen will start flashing in the current set state and is ready for change.
- (B) Press SET while the display is flashing to change the setting to YES or NO.
- (C) The screen will stop flashing and remain in the set state if not operated within 30 seconds.
- (D) When the LIMIT is YES, the maximum output of the receiver is limited to 1V.

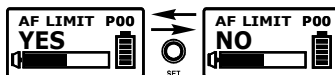

Fig. 10

8. ENCRYPT: Displays Information of Encryption, Fig. 11.

- (A) Press MODE and stop on the ENCRYPTION function; the LCD screen will start flashing in the current set state.
- (B) The screen will stop flashing and remain in the set state if not operated within 30 seconds.
- (C) The ENCRYPTION function displays status information only. Changing of the current status must be done from the receiver via the ACT function.
- (D) The ENCRYPTION function must be set at receiver first then using ACT to program the transmitter.



Fig. 11

9. RF POWER: RF Power Selection, Fig. 12.
- (A) Press MODE button for selection of RF POWER; the LCD screen will start flashing in the current set state and is ready for change.
  - (B) Press SET button to select and set HIGH or LOW.
  - (C) The screen will stop flashing and remain in the set state if not operated within 30 seconds.
  - (D) HIGH has 50mW transmitting power. LOW has 10mW transmitting power. Set appropriate power to meet region/country regulations.



Fig. 12

10. AF PHASE: Phase Selection of AF Inputs,  
Fig. 13.

- (A) Press MODE button for selection of AF PHASE; the LCD screen will start flashing in the current set state and is ready for change.
- (B) Press SET button to select and set NORM. or INV.
- (C) NORM.: AF input is positive (positive polarity)  
INVER: AF input is negative (reverse polarity)
- (D) The screen will stop flashing and remains in the set state if not operated within 30 seconds.
- (E) AF PHASE function provides users a phase selection for different condenser microphones. The normal setting is NORM., and INV. might be selected if two-wire condenser microphone is used.



Fig. 13

11. PHANTOM: Phantom Power, Fig. 14.

- (A) Press the MODE button to select the PHANTOM screen, the LCD screen will start flashing in the current set state and is ready for change.
- (B) Press the SET button to set OFF, 12V or 48V
- (C) The screen will stop flashing if not operated within 30 seconds.
- (D) PHANTOM is phantom power setting function, providing three selections: 12V or 48V or OFF, 12V or 48V is normally set for an external wired condenser microphone; OFF is normally set for an external wired dynamic microphone.
- (E) A general wired microphone with phantom power is allowed to use in 12V ~ 48V phantom power supply range. If it is determined that the phantom power wired microphone can operate at 12V, it is strongly recommended to be set to 12V, it reduces transmitter power consumption significantly & extends battery life.
- (F) Phantom Power Status: P00 is turned off (OFF); P12 indicates 12V phantom power; P48 indicates 48V phantom power.
- (G) Maximum power supply of 10mA up to 48V phantom power usage. However, observe the total power consumption will increase significantly and battery life will therefore be reduced by 50% or more.



Fig. 14



## 12. SET LOCK: Setup and Change of Parameter Lock, Fig. 15.

- (A) Press MODE button once for SET LOCK display; the LCD screen will start flashing in the current set state and is ready for change.
- (B) Press SET button for UNLOCK or LOCK selection.
- (C) UNLK: To unlock; LOCK: To lock.
- (D) The screen will stop flashing and remain in the set state if not operated within 30 seconds.
- (E) When locked (LOCK), receiver settings cannot be changed including the powering on & powering off. To power off it needs to be in unlock mode (UNLOCK).
- (F) A sudden loss of power will deactivate the LOCK Function.

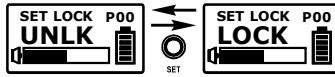

Fig. 15

## V. Battery Status

When the battery has less than 10% power remaining it must be replaced or recharged. If an under voltage condition continues, the LCD will show "OFF..." and the system will shut down to prevent being overly discharged.

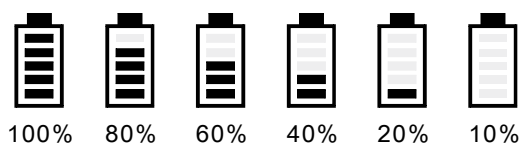

Fig. 16

## VI. Power On/Off

1. Press and hold power button for 2 seconds to power on & off.
2. When the power switch is turned off, the LCD will show "OFF..." (for Power Off) first and then the system will shut down and no further messages will be displayed.





Fig. 17

### 3. ERR: Error Code.

If the LCD displays "ERR" after turning on the power, it indicates the operation is not correct. The error codes are as follows:

- (A) ROM-ER → Transmitter does not have the initial data so the microphone is completely dead and cannot be programmed.
- (B) ERROR1 → Failure on RF circuitry, frequency cannot be programmed.
- (C) NO---03 → Frequency to be programmed into the transmitter exceeds the highest frequency of the designated frequency band of the transmitter.
- (D) NO---04 → Frequency to be programmed into the transmitter exceeds the lowest frequency of the designated frequency band of the transmitter.

VII. MUTE (ON/OFF), Fig. 18

1.  Light on: "Muted". Function setting is not affected and ACT synchronization is allowed.
2.  Light off: "Not Muted".
3. MUTE setting is not affected in LOCK mode.

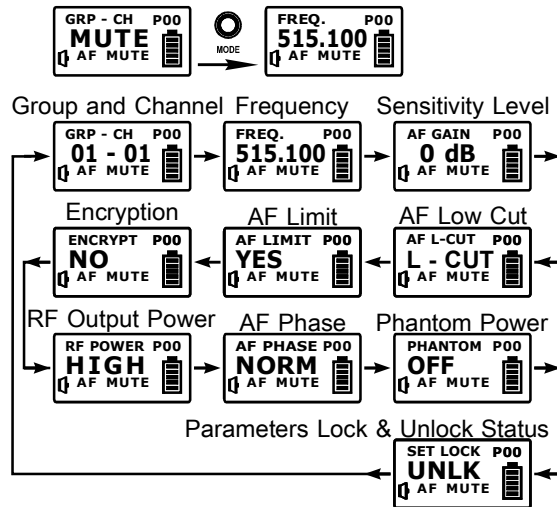
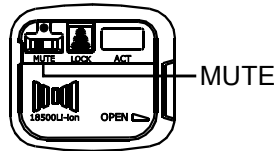

Fig. 18

### VIII. Insertion and Replacing the Batteries, Fig. 19

- 
- The diagram illustrates the process of inserting and replacing a battery in five sequential steps:
- Step 1:** The transmitter is shown with a small tab labeled "LOCK" on the battery cover. An arrow points to this tab, indicating it should be pushed up and outward.
  - Step 2:** The battery cover is shown swung open to the side, revealing the battery compartment.
  - Step 3:** A cylindrical 18500 rechargeable battery is being inserted into the compartment. The positive (+) end is facing inward and the negative (-) end is facing outward.
  - Step 4:** The battery cover is being pushed back into its original position to lock the battery in place.
  - Step 5:** The transmitter is shown with the battery cover fully closed and locked.
1. Push up the battery cover lock towards outward direction, and push the battery cover sideways to open.
  2. Ready for a 18500 rechargeable battery insertion or replacement.
  3. Insert one 18500 rechargeable battery as shown below with positive (+) end towards inside compartment.
  4. Push the battery cover back for a secured lock.
  5. Make sure the battery cover is locked and tightly secured.

Fig. 19

6. Attention: Power off the transmitter to avoid additional battery use. Remove the battery if it will not be used for an extended periods of time.

### IX. MP-80 Battery Charger (Optional)

1. TA-80 transmitter can be recharged in MP-8T or MP-80, Fig. 20, 21. 18500 recharge batteries can be recharged in MP-80, Fig. 22.
2. MP-8T, Fig. 20.

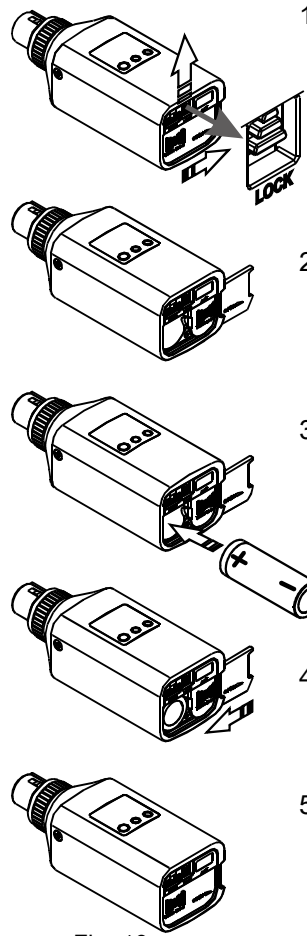
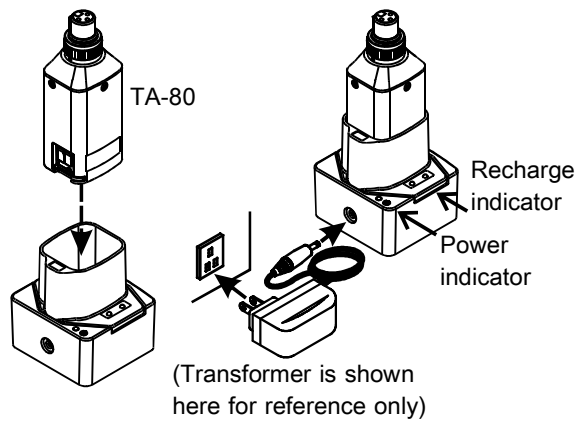

Fig. 20: Recharged in MP-8T

3. MP-80.

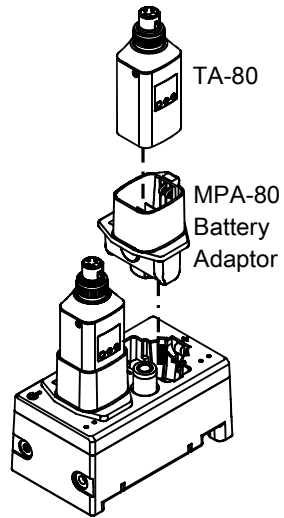

Fig. 21: Recharged in MP-80

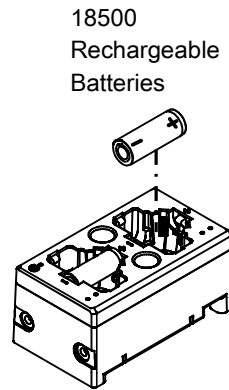

Fig. 22: 18500 rechargeable battery recharged in MP-80

## X. Accessories (Optional)

### 1. Measurement Microphone, Fig. 23.

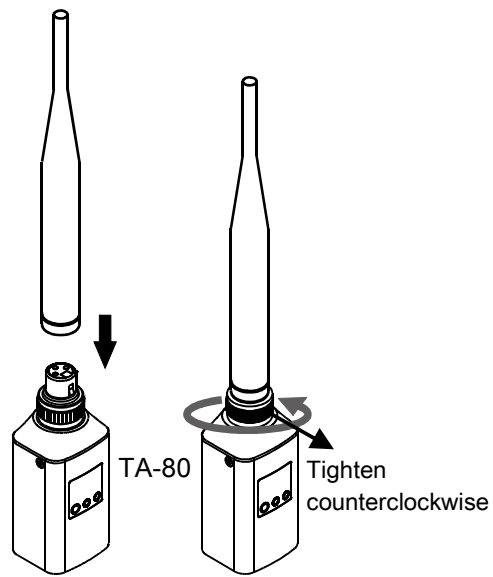

Fig. 23



2. TA-8A: Connecting with TA-80 and a microphone, Fig. 24.

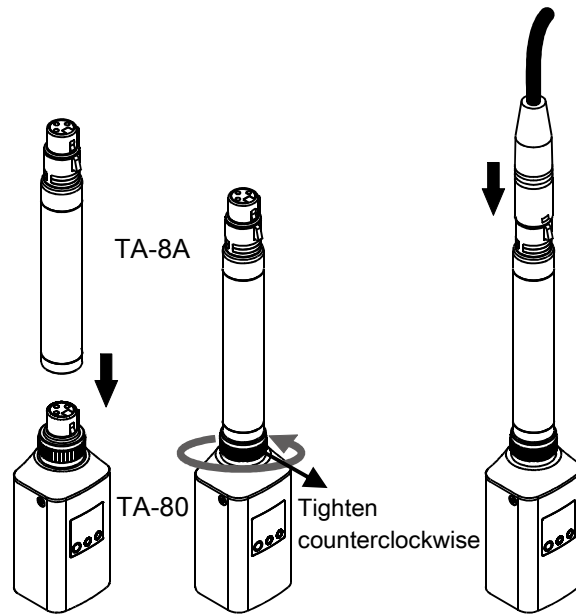

Fig. 24

3. Assemble the TA-8A holder onto a mic stand with extending boom arm.

(A) TA-8A holder assembly, Fig. 25.

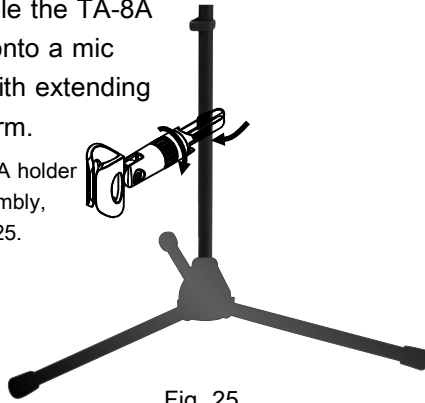

Fig. 25

(B) Assembly complete, Fig. 26, 27.



Fig. 26

Rechargeable Digital Wireless Plug-on Transmitter

---

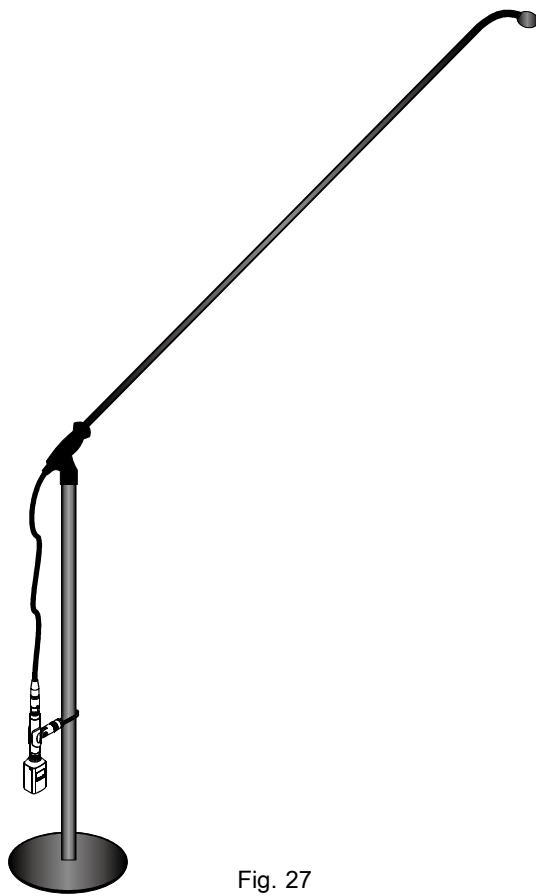

Fig. 27

- (C) After assembly, the mic cable shouldn't hang on the holder to prevent from electric interference.



Fig. 28

## XI. Notes

1. Refer to actual product in the event of product discrepancy.
2. Frequency range and maximum deviation comply with the regulations of different countries.

## Rechargeable Digital Wireless Plug-on Transmitter

---

### FCC Statement

FCC Caution: To assure continued compliance, any changes or modifications not expressly approved by the party responsible for compliance could void the user's authority to operate this equipment. (Example - use only shielded interface cables when connecting to computer or peripheral devices).

THIS DEVICE COMPLIES WITH PART 74 OF THE FCC RULES. This equipment complies with FCC RF radiation exposure limits set forth for an uncontrolled environment.

### Industry Canada Statement

This device complies with Industry Canada licence-exempt RSS standard.

Operation is subject to the following two conditions: (1) this device may not cause interference, and (2) this device must accept any interference, including interference that may cause undesired operation of the device.

Le présent appareil est conforme aux CNR d'Industrie Canada applicables aux appareils radio exempts de licence. L'exploitation est autorisée aux deux conditions suivantes: (1) l'appareil ne doit pas produire de brouillage, et (2) l'utilisateur de l'appareil doit accepter tout brouillage radioélectrique subi, même si le brouillage est susceptible d'en compromettre le fonctionnement.

## Rechargeable Digital Wireless Plug-on Transmitter

---

### Disposal



2005-08-18

Dispose of any unusable devices or batteries responsibly and in accordance with any applicable regulations.

Disposing of used batteries with domestic waste is to be avoided!

Batteries / NiCad cells often contain heavy metals such as cadmium(Cd), mercury(Hg) and lead(Pb) that makes them unsuitable for disposal with domestic waste. You may return spent batteries/accumulators free of charge to recycling centres or anywhere else batteries/accumulators are sold.

By doing so, you contribute to the conservation of our environment!



**MIPRO**<sup>®</sup>  
MICROPHONE PROFESSIONALS

**MIPRO Electronics Co., Ltd**  
Headquarters: 814 Pei-Kang Road, Chiayi, 60096, Taiwan  
Tel : +886.5.238.0809      Fax : +886.5.238.0803  
www.mipro.com.tw      mipro@mipro.com.tw

All rights reserved. MN 019/01  
Do not copy or forward without prior approvals MIPRO.  
Specifications and design subject to change without notice.



2CE547B