

MODEL: SKYLOS / SKYLOS NV

CODE: CJ3004 / CJ3007

September 16, 2024

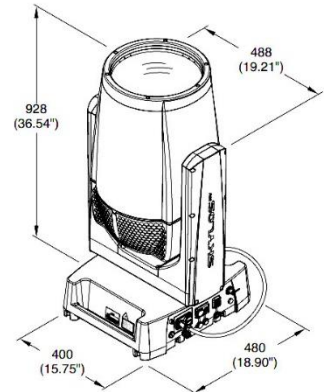
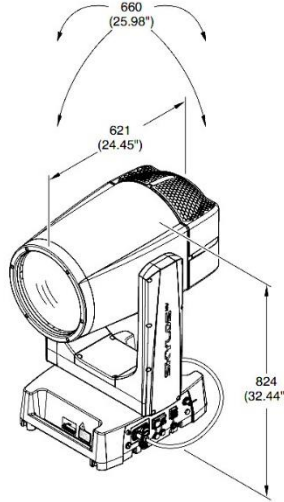

#### LIGHT SOURCE:

- Source type:** • Laser
- Power:** • 300 W
- Color temperature:** • 10000 K
- Laser life expectancy:** • 30.000 Hrs L70\*

\* It may vary depending on various factors, such as the type of use and environment

#### PHOTOMETRIC DATA:

- Zoom range:** • 0,5 – 5°
- Front lens:** • Ø 300 mm
- Optical syst.:** • High efficiency

#### NOISE LEVEL:

- Fixed presets:** • 52,6 dBA

#### CONTROL & CONNECTIONS:

- Personalities:** • 1 mode with 20 control channels
- Protocols:** • DMX, Art-Net, sACN, RDM  
• CRMX (Lumen Radio/Wireless solution)
- Connectors:** • Locking 5 pin XLR IN/OUT  
• RJ45 IN
- Power con.:** • PowerCon True1 IN/OUT
- Web server:** • Built-in
- CloudIO:** • Fully compatible

#### DYNAMIC EFFECTS:

- Colors:** • Color wheel with 14 dichroic colors
- Gobos:** • 1 slot for customizable fixed gobo  
• Ext. diam.: 25,9 mm  
• Image diam.: 16 mm  
• Thickness: 1,1 mm
- Frost:** • Linear heavy frost 5° for wash effect
- Rotating effects:** • Wheel with 2 positions: 6 faced prism + 5 faced linear prism  
• 4 faced fixed prism on a separate channel
- Movement:** • Tilt: 270° - 16 bit  
• Pan: 540° - 16 bit  
• Accuracy: Resolution ± 0,2°  
Range 0,4°
- Automatic repositioning
- Mechanical Pan/Tilt lock for safe transportation and maintenance
- Fast/Normal speed selectable via function channel
- Beam:** • Motorized zoom
- Dimmer / Shutter:** • High resolution electronic dimmer - 24 bit  
• High speed electronic shutter and strobe

## HARDWARE & SOFTWARE:

---

- Long life self-charging battery
- Display graphic LCD backlit B/W display
- Firmware upload from another fixture
- Firmware upgrade via Web Server
- Diagnostic
- DMX monitoring
- Remote access through RDM

## HOUSING:

---

- Aluminium and steel structure with plastic covers
- Two side handles for transportation
- IP66 protection rate
- IK06 impact resistance rate
- Working in any position
- Hanging system: with fast-lock Omega clamps (1/4) turn on the base
- Optional safety chain

## ELECTRICAL:

---

- Operating voltage:** • 100-120 / 200-240V, 50/60 Hz
- In/Out MAX:** • Mains out MAX 1 fix. MAX 1200 VA
- Power Supply:** • Electronic auto range with active PFC
- MAX power consumption:** • 900 VA

## THERMAL SPECIFICATION:

---

- MAX Ambient temperature:** • 45°C (113°F)
- Min Ambient Temperature:** • -40°C (-40°F)
- MAX temp. of the ext. surface:** • 55°C (131°F)
- Total heat dissipation:** • 3074 BTU/hr ±10% / 3240 kJ/hr ±10%

## SAFETY SPECIFICATIONS:

---

- Min. dist. of illum. objs:** • 30 m (98 ft 5 In)
- Min. dist. from flamm. mat.:** • 0,2 m (0 ft 8 In)
- Protections:**
- Thermally protected power supply (overheating and cooling failure)
  - Power fuse: T10A 250V (6,3x32 mm)
  - External fuse (for battery): T2A 250V (5x20 mm)
  - Forced ventilation with axial fans

## COMPLIANCE:

---

### CE Marking (in conformity to the following):

- 2014/53/EU - Radio Equipment Directive (RED)
- 2011/65/EU - Restriction of the use of certain hazardous substances (RoHS)
- 2009/125/EC - EcoDesign requirements for Energy-related Products (ErP)

### UKCA conforms to UK regulations:

- S.I. 2017 N.1206
- S.I. 2012 N.3032
- S.I. 2021 N.745

### cETLus LISTED:

- UL 1573:2003
- CSA C22.2 N.166:2015

## PACKAGING:

---

- Total carton box
- Flight case

## WEIGHT & SIZES:

---

- Weight:** • 59,9 Kg (132.1 lbs)
- Base Dim.s:** • 400 x 480 mm  
• 15.75 x 18.90 In
- Height with vert. head (h):** • 928 mm  
• 36.54 In
- Dist. b/t 2 fixt:** • 1000 mm  
• 39.37 In

## ACCESSORIES:

---

- Omega bracket:** • 2x183102/805 (Included)
- ETL Power:** • CAB02B-802 (Optional)\*  
\* Cord 1.5 m (bare end with IP65 PowerConTrue1 conn.)
- Flight case (1 pos):** • CF1027 (Optional)
- Safety Chain:** • 105041-001 (Optional)
- Clamp:** • C21070 (Optional)