

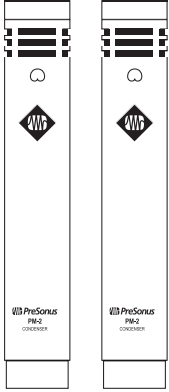

# PM-2

Small Diaphragm Cardioid Condenser Microphones



## Key Features

- Two (2) matched small-diaphragm condenser microphones
- Cardioid polar pattern
- The right choice for stereo recordings of acoustic instruments, drum overheads, ensembles and more
- Sold as a sonically matched pair
- 3/4-inch (19 mm), gold-sputtered capsule
- Ultra light chassis for easy positioning
- Mic clips and stereo bar for XY mic placement included

## Sonically matched for precise stereo imaging

Ideal for stereo recordings of acoustic instruments, drum overheads, ensembles and more, the PreSonus PM-2 stereo microphone set provides the tools you need to create professional results. Each PreSonus PM-2 small-diaphragm cardioid condenser microphone is equipped with a 3/4" gold-sputtered capsule housed in an ultra-light chassis, making it easier to perfectly position your microphones without fighting gravity. Sold as a sonically matched pair, the PM-2 comes equipped with a stereo bar for XY mic placement. PM-2 microphones can be used together or individually, making them an excellent addition for any home or professional recording environment.

## Frequency response

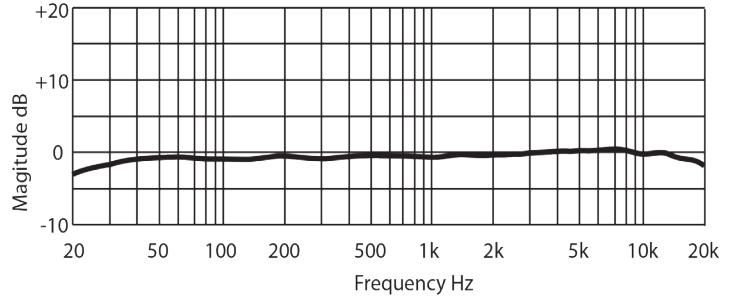

## Polar pattern

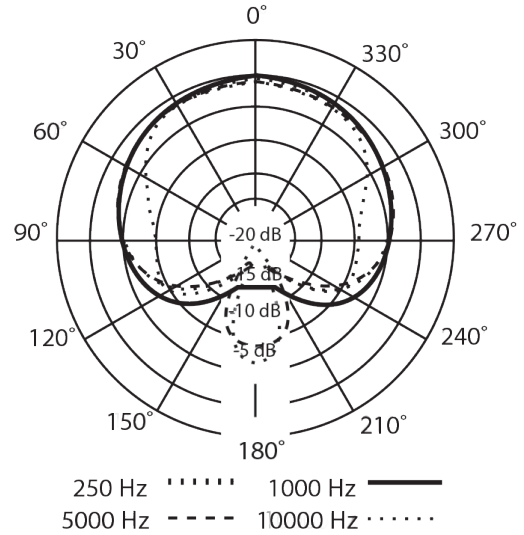

## Technical specifications

Capsule Type	19 mm, gold sputtered 6 micron Mylar, small-diaphragm condenser
Preamp Type	Class A FET
Sensitivity	8 mV/Pa
Frequency Response	40 Hz to 18 kHz
Polar Pattern	Cardioid
Equivalent Noise Level	22 dB SPL A-wtd
Maximum SPL	135 dB
Total Load Impedance	>1 kΩ
Output Impedance	200Ω
Powered By	48V Phantom Power