

# CLUSTER **S2i**



USER MANUAL

## CONTENT

### 1. Safety Informations

1.1. General Preventive Measures	3
1.2. Regulations for equipment that connects to power mains	4
1.3. Technical warnsigns and explanation	5

### 2. Introduction

2.1. About us	6
2.2. CLUSTER S2i	6

### 3. General Product Information

3.1. Scope of delivery	7
3.2. Control Functions	7
3.3. Features	7

### 4. Installation & Setup

4.1 Physical Installation and Rigging	8
4.2 Connections	13
4.2.1. AC Power	13
4.2.2. DMX Connection	14
4.2.2.1. Cable Connection	14

### 5. Operation

5.1 Start up	15
5.2 Control Display	15
5.3 Display Short Cuts	15
5.4 Configuration	17
5.4.1 Set DMX Start Address (Direct Access)	17
5.4.2 Selecting DMX Mode	17
5.4.3 Stand Alone	18
5.4.4 Settings	22
5.4.5 System Info	29

### 6. Accessories

6.1 Accessories	30
-----------------	----

### 7. Technical Data / Diagrams

7.1 Technical drawings and measurements	31
7.2 IP Rating	32
7.3 Technical Data	33
7.4 DMX-Charts / Color Macro Charts / CCT Chart	35
7.5 RDM Templates	39
7.6 Firmware Update	40

### 8. Troubleshooting

41

### 9. Manufacturer's Declaration

41

## 1. SAFETY INFORMATION

### 1.1. General Preventive Measures

- 1.1.1. Please read, understand and follow the instructions.
- 1.1.2. Store the instructions and information in a safe place.  
Best solution is the ring binder provided by ROXX.
- 1.1.3. Follow all safety warnings. Under no circumstances remove safety warnings or other information from the equipment.
- 1.1.4. Don't use the equipment for any other intended purpose or manner.
- 1.1.5. Use only stable and compatible stands and/or brackets. Especially when fix installed. Make sure the wall brackets are properly installed and safe. Make sure the device is securely installed and cannot fall.
- 1.1.6. Check the safety regulations applying for your country before and during installation.
- 1.1.7. Keep the device away from heat! Don't place/install near heaters, ovens or any source of heat. Make sure that the device always is efficiently cooled and cannot overheat.
- 1.1.8. Always guarantee that ventilation and cooling slots are clean and not blocked.
- 1.1.9. Item must be away minimum 20cm from anything around and above it.
- 1.1.10. Do not use this device close to water.
- 1.1.11. Do not expose this equipment to flammable materials.
- 1.1.12. Make sure that no objects can fall into the device.
- 1.1.13. Only use this device with the accessories recommended by the manufacturer.
- 1.1.14. Always check the equipment for housing damages, so that no water can enter the device. No containers containing liquids of any kind should be place on top of the unit.
- 1.1.15. Opening or modifying this device is only allowed by authorized and qualified persons.
- 1.1.16. All cables need to be checked after connecting the device in order to prevent damage or accidents.
- 1.1.17. Make sure that the device is transported safe and packed proper in order to prevent damage of any kind.
- 1.1.18. Once you notice improper function of your device due to damage, electric shock or anything similar, immediately unplug the unit from the mains outlet and contact our service department.
- 1.1.19. Clean the device with a dry cloth.

- 1.1.20. Observe all disposal laws applicable in your country. Especially for the packaging.
- 1.1.21. Plastic bags are not a toy! Keep away from children!
- 1.1.22. Please note that changes or modifications which are not approved by the party responsible for compliance will void the user's authority to operate the device.

## **1.2 Regulations for equipment that connects to power mains**

- 1.2.1. If an earthing contact is available in the used power cord, it must be used in combination with a power outlet, providing a protective ground. In no circumstances should the protective ground be deactivated.
- 1.2.2. Do not switch on the device immediately after it has been in strong different temperatures, especially after transport. Let the device acclimatize to the temperature in the room of usage first to prevent moisture and condensation.
- 1.2.3. Verify that the correct voltage and frequency are available in the area of operation, before connecting the unit to the mains outlet.
- 1.2.4. If the plug doesn't fit in your mains outlet, contact your electrician.
- 1.2.5. Make sure your power cord/adaptor/connector does not show signs of kinks/warps or is being stepped on.
- 1.2.6. Always disconnect the unit when not in use or being cleaned. Don't pull on the cord to disconnect. Only touch power connections with dry hands!
- 1.2.7. Don't switch the unit on/off rapidly. This may cause damage.
- 1.2.8. If a fuse needs to be replaced, ALWAYS make sure that exactly the same fuse will be used (type and rating). Repeatedly blown fuses need to be checked by an authorised service technician.
- 1.2.9. In the risk of lightning strike all units need to be unplugged from the mains in order to prevent damage.
- 1.2.10. During installation there must be a voltage free condition.
- 1.2.11. The device needs to be cleaned and serviced regularly and will credit this with a longer life cycle. Dust, dirt, moist, water, smoke, nicotine or anything similar inside the unit will cause damage/malfunction.
- 1.2.12. The unit needs to have at least 0,5m distance to anything flammable.
- 1.2.13. You have to make sure that any electrical installation applies to the laws of your country. Correct power cables and applying standards have to be used.

### 1.3. Technical warnsigns and explanation



In order to prevent the risk of an electric shock, under no circumstances remove the cover/back or open the unit in any way! No user serviceable parts are inside. Service, maintenance and repairs should only be done by qualified service personnel or the manufacturer.



Dangerous uninsulated voltage inside the device can cause an electrical shock when opened by unqualified personnel.



Important operating and maintenance instructions apply!



Do not operate this device in tropical climates.



CAUTION! Intense LED light source! Risk of eye damage. Do not look into the light source



The housing surface of the spotlight can heat up to temperatures as high as 70 °C in regular use. Ensure that it is not possible to come into contact with the housing unintentionally. Always allow sufficient time for the lamp to cool down before dismantling, carrying out maintenance work or charging etc..



#### IMPORTANT INFORMATION!

- This is a product which has been developed for professional usage in event technology. It is not suitable as a household lighting.
- NEVER stare, not even temporarily, directly into the light source.
- Don't use magnifiers or any other optical instrument to look at the beam.
- The effects of this device, especially the stroboscope effect, can cause problems for sensitive people or may even cause epileptical seizures.

## 2. INTRODUCTION

### 2.1. About us

*The name ROXX® came easily.*

Combined with the concentrated knowledge and many years of experience, our three founders, who have been leaving their mark in the event and lighting industry for many years already, came together in 2020 to start this outstanding venture.

Product development, sales and marketing as well as the exceptional know-how and the profound rooting in the field of the professional lighting technology belong to our core competences and therefore guarantee extremely innovative and reliable products, excellent support and professional service in every aspect.

*Designed & developed in Germany*

ROXX® products are developed and designed in Germany. Always in tight consultation with our customers and experts who will eventually be working with these tools. This ensures innovative, easy-to-use and performance-oriented solutions, which provide added value for our customers.

*Made to last*

Recommended for permanent outdoor use, most ROXX® products feature additional corrosion protection and enhanced IP66 equipment protection, thereby providing that crucial extra for a wider range of applications. In addition to architectural or theme park applications, even fixed installations in coastal or offshore areas with high salt exposure can be reliably implemented over long periods of time.

### 2.2. CLUSTER S2i

The CLUSTER S2i is a versatile, high-power pixel-mappable strobe & washlight engineered to meet the demands of architectural applications. Its sleek, modern design, with a durable white finish (RAL 9010) and C5-H coating, ensures it blends seamlessly into any setting, while its robust construction allows it to withstand the rigors of outdoor environments. With a 5-year warranty, the CLUSTER S2i is built for reliability and long-term use in challenging conditions.

Whether you are lighting up a stage, illuminating a building façade, or creating immersive environments, the CLUSTER S2i delivers the power, flexibility, and durability you need to make an impact.

Equipped with 612 cool white LEDs (7000K) and 680 RGB LEDs, the CLUSTER S2i delivers an impressive luminous flux of 57,750 lumens at full output (1200W), making it ideal for both vibrant light shows and architectural highlights. Its combination of CW and RGB LEDs provides a wide range of lighting effects, from pure, crisp whites to rich, dynamic colors, offering creative flexibility for designers.

The spotlight is designed to endure harsh environments, boasting an IP66 rating for water and dust protection, and an IK08 impact resistance, ensuring it stands up to the demands of outdoor installations. This rugged durability makes the CLUSTER S2i a reliable choice for long-term installations in both entertainment venues and architectural spaces.

There are several mounting options – Camlock mounts on top and back enable the use of Omega-Brackets, Yokes can be attached to M12 mounting points on all sides, or the internal C-Lok system can be used for seamless inter-connection. Pre-Link Magnets on top and side help to align the fixtures and allows “one-handed” operation for secure locking.

### 3. GENERAL PRODUCT INFORMATION

#### 3.1. Scope of delivery

- ⊕ 1x CLUSTER S2i
- ⊕ 3m Power Cords for Power I/O open ends, cable ferrules
- ⊕ Pre-installed PUK

We're offering a wide range of professional accessories (optional). Please see under menu 6 or at our website [www.roxxlight.com](http://www.roxxlight.com)

#### 3.2. Control Functions

- Simple Mode 15CH, Easy Mode 39CH, Standard Mode 71CH (default mode), Pure Mode 112CH Single Pixel 8 Bit with Strobefunction, Pure Mode 209CH Single Pixel 16 Bit with Strobefunction, Full Access Mode 178CH 8 Bit single Pixel with Pattern, Full Access Extended Mode 275CH 16 Bit with Pattern
- Art-Net / sACN
- RDM (Remote Device Management)
- Stand Alone Functions including auto programs, LEE adjusted color macros, custom color templates and Tunable White
- Master & Slave

#### 3.3. Features

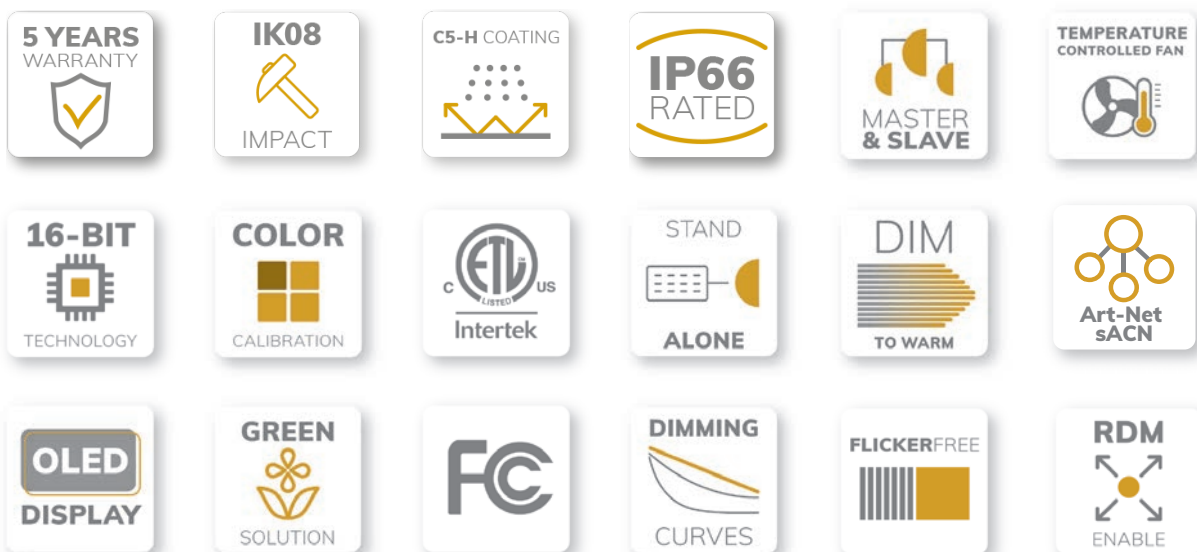





2. By included yoke with several mounting points:

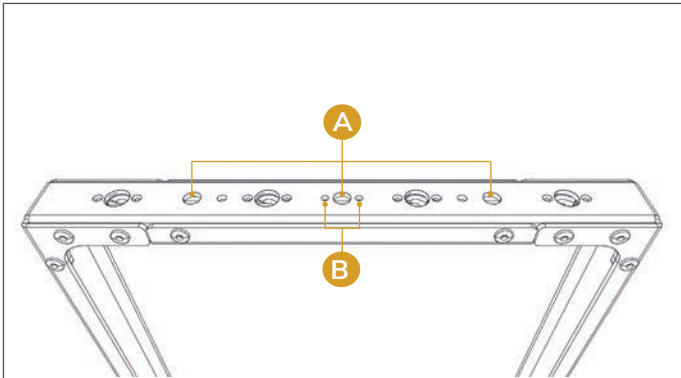

Multiple mounting points:

A: 3x 13mm / 1/2" holes for Clamp fixation

B: 1x centric TV Spigot attachment

3. Using optional ROXX RIGGING BRACKET

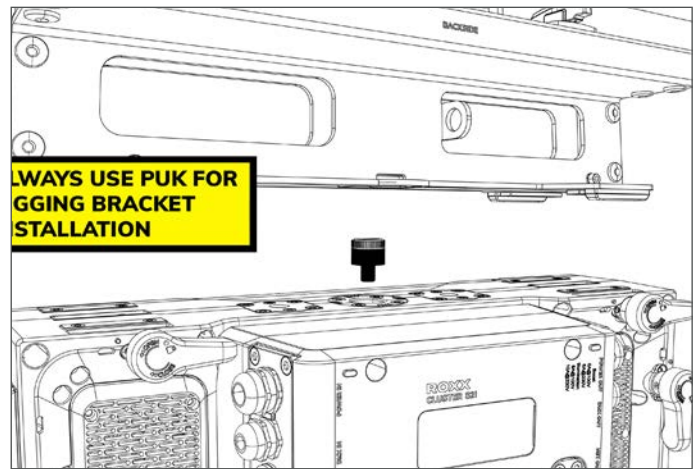
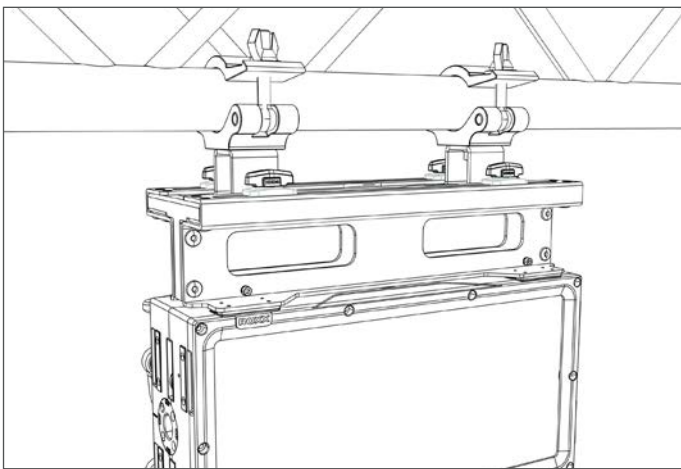

For seamless connection of multiple Blinders, to avoid gaps due to bracing of the truss structure by variable, sliding mounting positions.



### Product Clustering

All CLUSTER products can be easily connected both horizontal and vertically, by using the integrated C-Lok system. The series is made to enable toolless multiple array configurations, scalable from a single vertical line, to massive matrix like arrays.

To connect the devices with each other, proceed as follows in sequence:

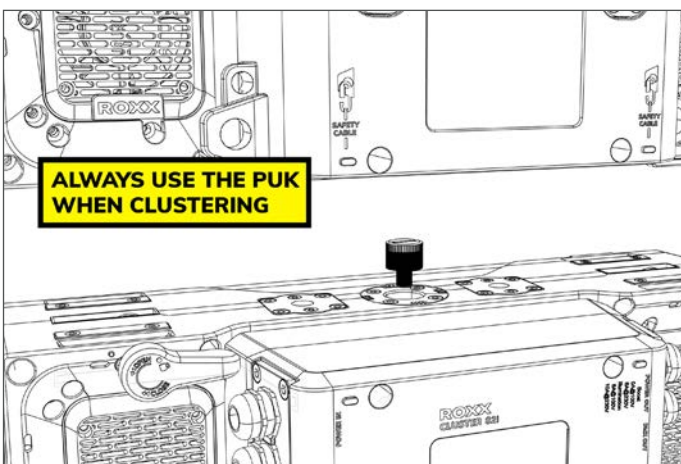

1. Bring the devices together with the respective top and bottom side.

A so-called centering puk is pre-installed on the top of every cluster device.

This should always be installed when connecting the devices to each other.

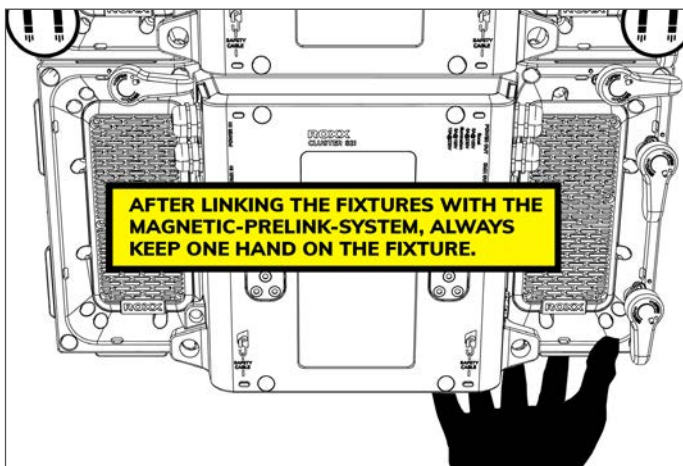

2. Pre-Link Magnets on top and side help to align the fixtures due cluster process and giving support operation for convenient and save interlocking.



**Important Note:**

Even though the pre-link magnet system is strong enough to hold the devices together, at least one hand must always remain on the device for support during the connection.

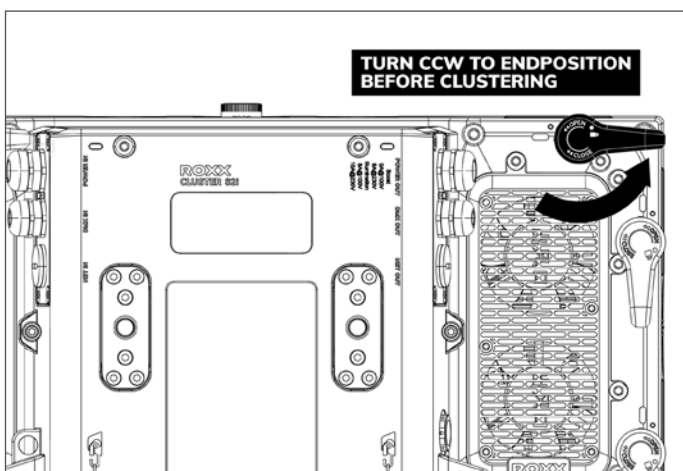

3. Make sure that the C-Lok hooks are turned counterclockwise (CCW) to the end-position first before you finally lock the C-Loks.

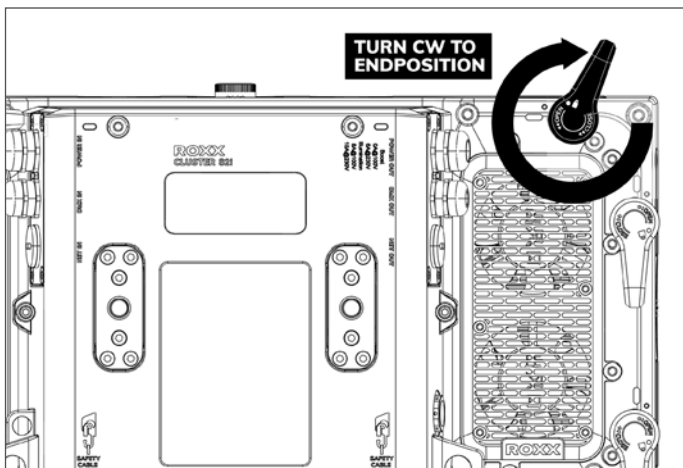

4. For locking all C-Lok's, please turn them clockwise into end-position.

**Note:**

As soon as both dot indicators are in line, the C-Lok is securely locked



**Maximum Tensile and Torsion Load**

Before setting up Cluster configurations, be aware of the maximum tensile and torsion load, listed here below. Also make sure the mounting clamps are capable of supporting the total weight of your configuration.

The different rigging options of all Cluster products result in different maximum tensile and torsion loads that must not be exceeded for a safe overhead installation.

**The maximum loads listed here below take into account the 10-fold safety!**

1. Rigging by integrated 1/4 turn Camlocks on top- or rear side

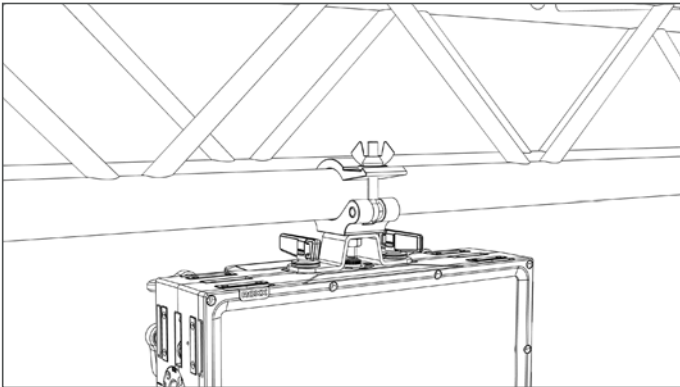

Max. Tension Load: 90kg  
Max. Torsion Load: 18.703 Nmm

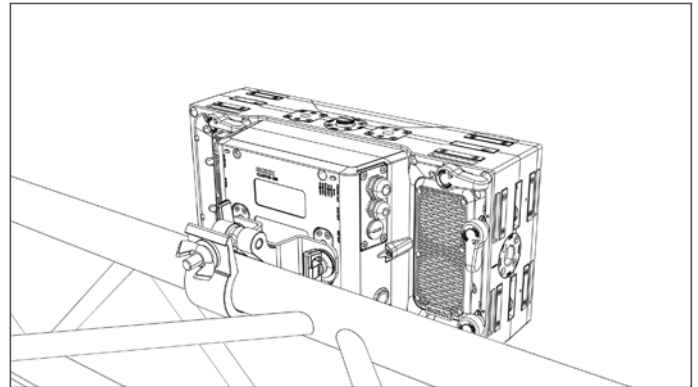

Max. Tension Load: 90kg  
Max. Torsion Load: 14.201 Nmm

2. Rigging by Yoke with multiple mounting points

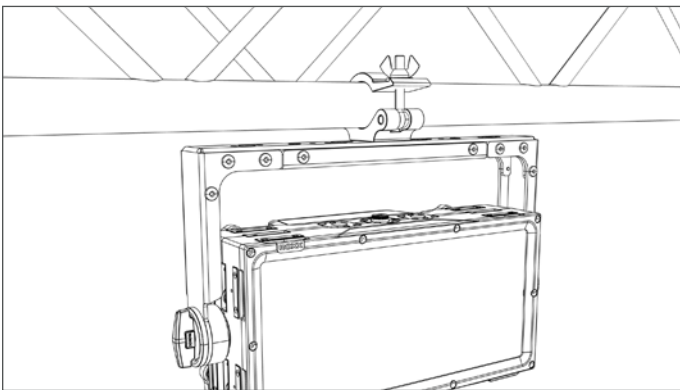

**a. With 1x Mounting Clamp**

Max. Tension Load: 40kg  
Max. Torsion Load: 4.414 Nmm

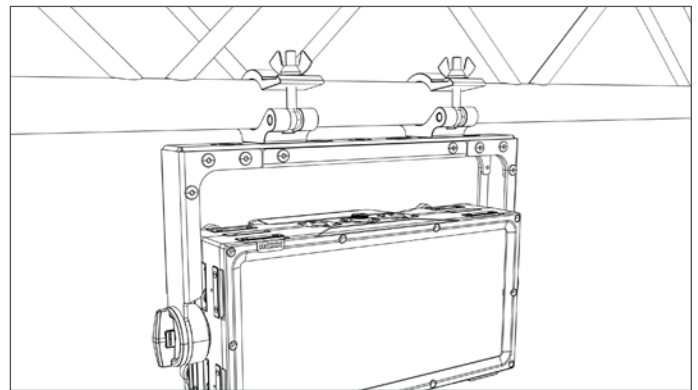

**b. With 2x Mounting Clamp**

Max. Tension Load: 77kg  
Max. Torsion Load: 7.308 Nmm

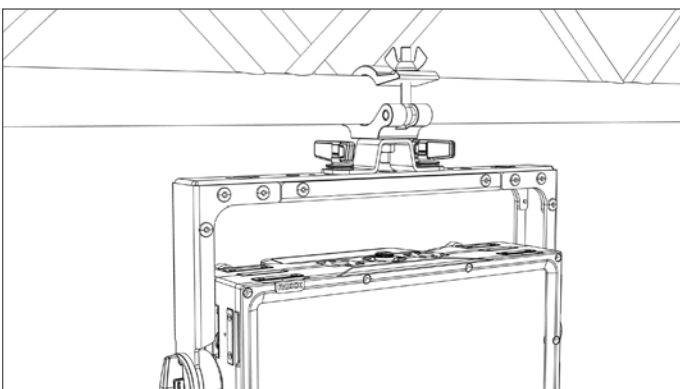

**c. With 1x Omega Bracket**

Max. Tension Load: 51kg  
Max. Torsion Load: 4.768 Nmm

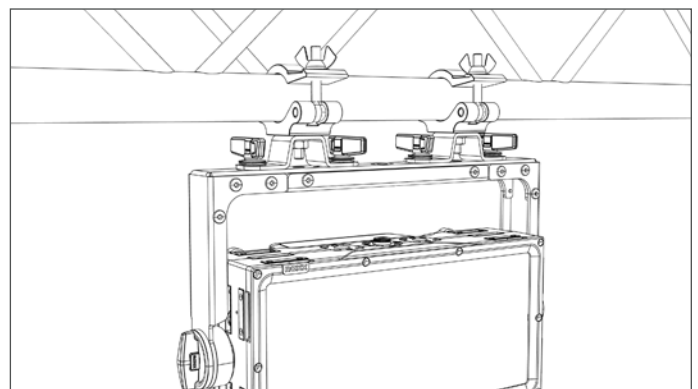

**d. With 2x Omega Bracket**

Max. Tension Load: 90kg  
Max. Torsion Load: 5.943 Nmm

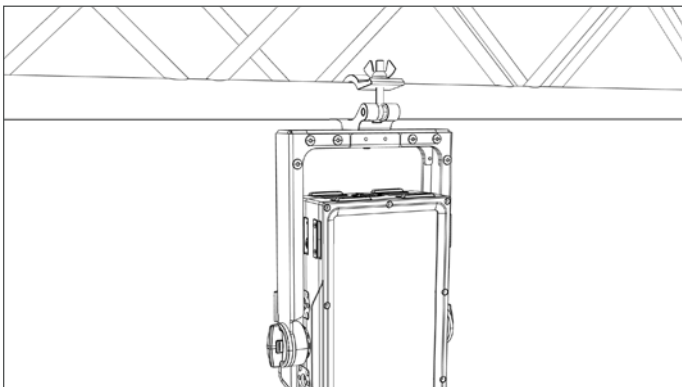

e. YOKE 2.2 with 1x Mounting Clamp

Max. Tension Load: 88kg

Max. Torsion Load: 8.238Nmm

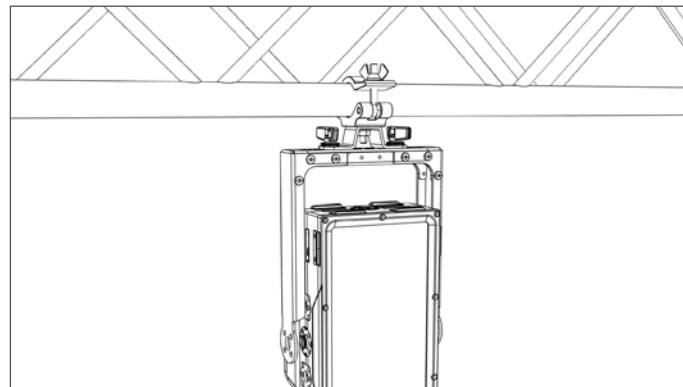

f. YOKE 2.2 with 1x Omega Bracket

Max. Tension Load: 66kg

Max. Torsion Load: 6.476Nmm

3. Using optional ROXX RIGGING BRACKET with 2x Mounting Clamps

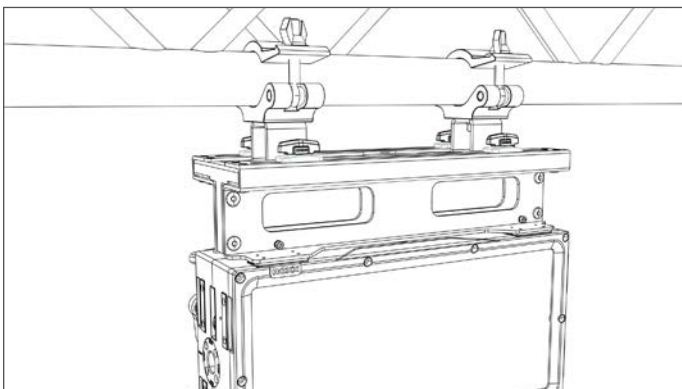

Max. Tension Load: 72kg

Max. Torsion Load: 6.326 Nmm



**Important Note:**

Please be aware of using the centering PUK for safe RIGGING BRACKET installation to the CLUSTER device.

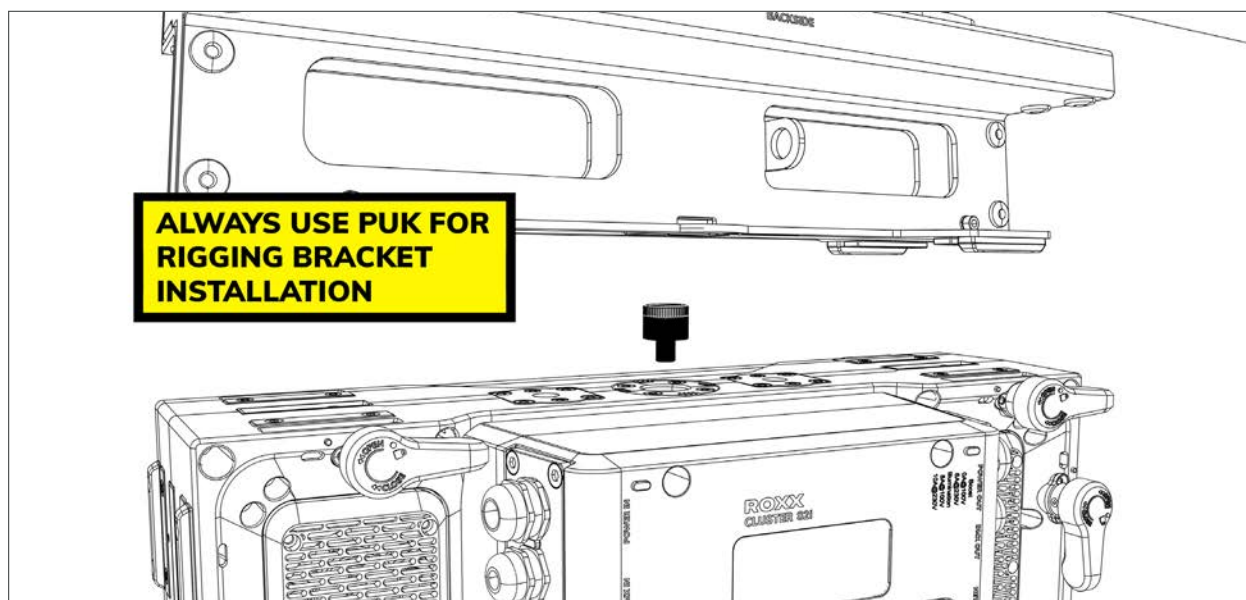

## 4.2 Connections\*

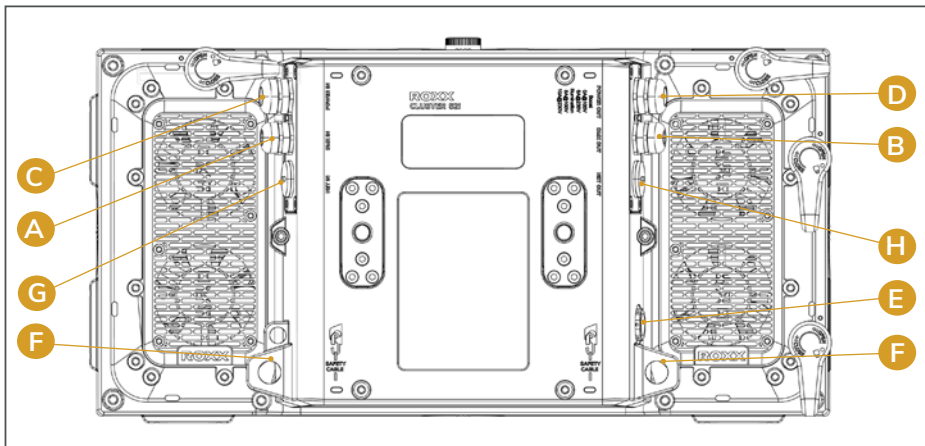

**A: Mains In:** PG13 cable gland including pre-installed 3m power cord, open ends and cable ferrules (3x1,5mm)

**B: Mains Out:** PG13 cable gland including pre-installed 3m power cord, open ends and cable ferrules (3x1,5mm)

**C: DMX IN:** PG9 cable gland including 3m pre-installed DMX cable, open ends

**D: DMX OUT:** PG9 cable gland including 3m pre-installed DMX cable, open end

**E:** GoreTex

**F:** Safety Eyelet

**G:** Ethernet IN, Art-Net/sACN: PG 9 with sealing cap. Innerside RJ45 connector

**H:** Ethernet Out, Art-Net/sACN: PG 9 with sealing cap. Innerside RJ45 connector

### \*Note:

**In order to provide protection from spraying water, in accordance with protection class IP66, please keep the pre-installed rubber sealing caps fixed inside PG cable glands if no cable is carried out.**

### 4.2.1. AC Power

The CLUSTER S2i operates on any 100–260 V, 50/60 Hz AC mains power supply with a maximum power consumption of 1250W. Connect the fixture to AC power using the pre-installed cable or similar one. For temporary installations, the mains cable must be fitted with a grounded connector intended for exterior use. The fixture must be grounded/earthed and be able to be isolated from AC power. The AC power supply must incorporate a fuse or circuit breaker for fault protection.

Wire Color (EU models)	Wire Color (US models)	Conductor	Symbol
Brown	Black	Live	L
Blue	White	Neutral	N
Yellow / Green	Green	Ground (earth)	⊕ or ⊚



### Warning!

Read “Safety Informations” starting on page 3 before connecting the fixtures to AC mains power! Do not connect the fixture to an electrical dimmer system, as doing so may cause damage that is not covered by the product warranty!

#### 4.2.2. DMX Connection

The CLUSTER S2i is fully controllable by DMX (USITT DMX512-A standard, based on RS-485) Art-Net, sACN and RDM.

##### 4.2.2.1. Cable Connection

If using a cabled DMX system, connect the DMX IN cable to the input connector and DMX OUT cable to the output. For correct pin assignment please see above picture. For outdoor installations, use only correct IP-rated XLR connectors.

Use shielded twisted pair cable designed for RS-485 devices. The cables are daisy chained between the fixtures, and up to 32 fixtures can be connected to the same DMX link. Up to 300 meters (1000ft.) of cable is achievable with high quality DMX cables. All DMX links must be terminated in the last fixture by connecting a DMX termination plug to the last fixture's 5 pin DMX out connector.

Standard microphone cable is not suitable for transmitting DMX.

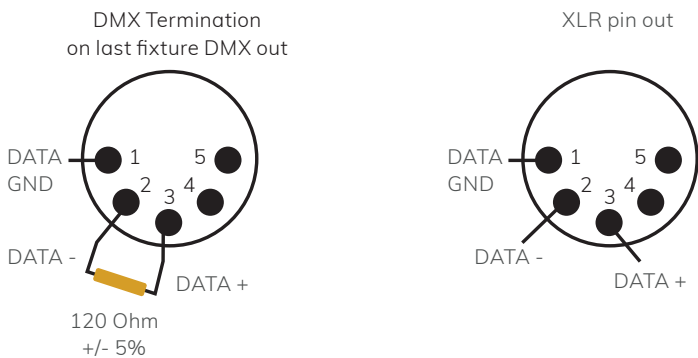

## 5. OPERATION

### 5.1 Start up\*

Once the fixture is connected to AC power, the boot process starts and the following information will appear on the display:

“Ready to ROXX”, the product name and the current software version.

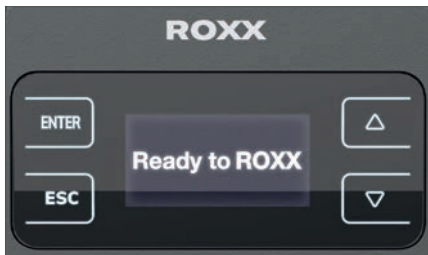

After this process, the fixture is ready for operation, and starts in the previously enabled mode.

**\*Note:**

**During boot process the fan spins up quickly to blow out some possible dust from last use.**

### 5.2 Control Display\*

OLED Display with Touch-Sensitive controls



Press **ENTER** to access the selection menu for system settings or confirm changes.



Press **ESC** to take a step back in the menu.



Press **arrows to scroll up and down** inside the menu and change values, such as DMX address.

**\*Note:**

**For a smooth navigation thru the menu settings, please make sure the display surface is dry and dust free.**

**After approximately 1 minute of inactivity inside the menu settings, the display will automatically jump back to home screen.**

### 5.3 Display Short Cuts\*

Short Cuts

For some always recurring functions the fixture allows quick and user-friendly access at home screen over some display control short-cuts:

#### User Reset or Factory Reset\*



Pressing **ESC+ENTER** simultaneously a Factory Reset or User Reset can be started.

By using the up/down arrows the Factory- or User Reset can be selected.

For confirming press **ENTER**, to jump back please press **ESC**.

**\*Note:**

**After Factory Reset all fixture settings are set back to factory default values.**

**After User Reset all user selected reset functions and user default values will set back.**

**Also a short self-test will start immediately while dimming in and out each single color.**

## Display Off



Pressing ESC + arrow down simultaneously the display backlight function will set to off and the display will turn off immediately. Once a control is pressed the display backlight will turn on.

## Manual display flip function\*



The fixture includes an auto display flip function by default.

To use the manual display flip function please disable the auto flip function under Settings / Display first. Once the auto display flip function is disabled you can use the manual display flip function by pressing arrow up + arrow down simultaneously. The display will rotate 180. By pressing both arrows simultaneously again the display will flip back.

### ⓘ \*Note:

Once the display is flipped both Up / Down controls will work according to the display rotation.

## 5.4 Configuration

### Home Screen

After boot process the fixture is ready for operation and starts in the previously enabled mode. At home screen the following information will appear, depending on the current operating mode:

- A DMX Address
- B Operating Mode (DMX Mode, Quick Light or Standalone Mode)
- C Next available DMX address depending on the fixtures DMX footprint
- D External Data protocol (DMX / Art-Net / sACN).
- E The dot indicates the active protocol

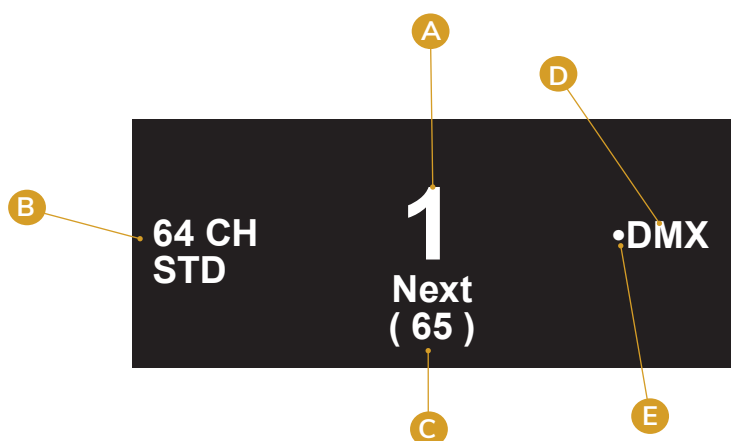

### 5.4.1 Set DMX Start Address (Direct Access)

At Home Screen the DMX address can be changed directly by using the up and down arrows. During this process the DMX address starts blinking, once it's confirmed by pressing ENTER it stops blinking.

If the DMX address will not be confirmed by ENTER within 10 seconds, the display will jump back and show the DMX address from before and stops blinking.



### 5.4.2 Selecting DMX Mode\*

At home screen please press ENTER to access to the main menu (level 1).

While using UP / DOWN arrows, please select the menu item “DMX Mode” and confirm by pressing ENTER.

In the following sub-menu (level 2), you can now choose between 7 different DMX operating modes while using the UP/Down arrows and confirm by pressing ENTER or jump back by pressing ESC.

After confirmation the display will jump back to main menu (level 1). Press ESC for homescreen, here the selected DMX mode will be displayed.

**\*Note:**

**For detailed information about the several DMX modes including channel assignment please see our DMX Control chart.**

Level 1

Menu
<ul style="list-style-type: none"> <li>➔ DMX Mode</li> <li>Stand Alone</li> <li>Settings</li> <li>System Info</li> </ul>

Level 2

DMX Mode
<ul style="list-style-type: none"> <li>➔ 15CH Simple</li> <li>39CH Easy</li> <li>71CH Standard</li> <li>112CH Pure</li> <li>209CH Pure Mode</li> <li>178 CH Full Access</li> <li>275CH Full Access Extended</li> </ul>

### 5.4.3 Stand Alone\*

Press ENTER to access to main menu (level 1).

While using the UP / DOWN arrows, please select the menu item “Stand Alone” and confirm by pressing ENTER.

In the following sub-menu (level 2), you can now choose between 5 different Stand Alone operating modes (Auto, Color Macro, Quick Color, Tunable White, User Color) ,Stop Stand Alone and Color Settings functions while using the UP/Down arrows and confirm by pressing ENTER or jump back by pressing ESC.

To finally use Stand Alone programs please make sure DMX is disconnected to the fixture, as this protocol has priority.

#### Stop Stand Alone

To stop a running Stand Alone mode immediately, please select “Stop Stand Alone” and confirm by pressing ENTER. The display will automatically jump back to level 1.

Level 1

Menu
<ul style="list-style-type: none"> <li>DMX Mode</li> <li>➔ Stand Alone</li> <li>Settings</li> <li>System Info</li> </ul>

Level 2

Stand Alone Mode
<ul style="list-style-type: none"> <li>➔ Stop Stand Alone</li> <li>Auto FX</li> <li>Color Macro</li> <li>Quick Color</li> <li>Tunable White</li> <li>User Color</li> <li>Color Settings</li> <li>Master</li> </ul>

### Auto FX\*

Select "Auto FX" by using the up/down arrows and press ENTER.

Here at sub-menu (level 3), you can choose between 10 different Auto Effects (Effect 1 - 10) and Stop Program. Using the Up/Down arrows you can select one of the 10 Effects and confirm by pressing ENTER or step back by ESC.

After confirming your preferred Effect, you can now adjust speed and brightness at level 4.

To adjust speed, please use the UP / DOWN arrows to select the menu item "Speed", and confirm with ENTER. After use UP / DOWN arrows to adjust the speed value between 000-100 and confirm by ENTER or jump back by ESC.

To adjust brightness please select "Dim" as per the procedure previously described and confirm with ENTER. After use UP / DOWN arrows again to adjust the brightness value between 000-100 and confirm by ENTER or jump back by ESC.

Once it's confirmed or denied the display will automatically jump back to level 3.

To stop running a selected Effect please chose "Stop Program" at level 3 or "Stop Stand Alone" at level 2.

For returning back to homescreen please press ESC three times.

At homescreen the selected Stand Alone mode "Auto" and the selected program will be displayed.

**\*Note: Using arrows UP /DOWN at homescreen Auto programs can be directly changed according to the list.**

Level 1

Menu
DMX Mode
➔ Stand Alone
Settings
System Info

Level 2

Stand Alone Mode
Stop Stand Alone
➔ Auto FX
Color Macro
Quick Color
Tunable White
User Color
Color Settings
Master

Level 3

Auto
➔ Stop Program
Effect 1
Effect 2
Effect 3
Effect 4
Effect 5
Effect 6
Effect 7
Effect 8
Effect 9
Effect 10

Level 4

Program
➔ Speed <0-100>
<b>(Default 50)</b>
Dim <0-100>

**Auto FX**  
Effect 1

### Color Macro\*

46 different color macros (34x matched LEE color filters, 6 LED colors and 6 different Whites) are available as presets. For each the brightness can be adjusted separately.

Level 1

Menu
DMX Mode
➤ Stand Alone
Settings
System Info

Level 2

Stand Alone Mode
Stop Stand Alone
Auto FX
➤ Color Macro
Quick Color
Tunable White
User Color
Color Settings
Master

Level 3

Color Macro
Color Off
➤ Color Macros
Color Macro Chart
Dim <0-100>

To select a color macro please press ENTER to access to main menu (level 1).

While using the UP / DOWN arrows select the menu item "Stand Alone" and confirm

by pressing ENTER. After please select the item "Color Macro" by using the up/down arrows and press ENTER again.

Using UP and DOWN controls, select your desired color preset and confirm with ENTER.

At level 3 you can adjust the brightness for the color preset between 000-100. Confirm by ENTER. For color blackout choose the item "Color Off".

ⓘ **Note:** Using UP / DOWN arrows at homescreen Color Macros can be changed according to the list.

Level 4

Gels - Color Macros for Standalone Mode			Gels - Color Macros for Standalone Mode			Gels - Color Macros for Standalone Mode		
Pos.	Gel Name	Color Number	Pos.	Gel Name	Color Number	Pos.	Gel Name	Color Number
1	Red	100% Red LED	17	jade	LEE 323	33	Special Med Lavender	LEE 343
2	Fire	LEE 019	18	Blue	100% Blue LED	34	Ultimate Violet	LEE 707
3	Medium Red	LEE 027	19	Sky Blue	LEE 068	35	Magical Magenta	LEE 795
4	Primary Red	LEE 106	20	Tokyo Blue	LEE 071	36	Chrysalis Pink	LEE 798
5	Med Amber	LEE 020	21	Light Blue	LEE 118	37	Specia KH Lavender	LEE 799
6	Dark Amber	LEE 022	22	Marine Blue	LEE 131	38	Bulb White	2700K
7	Deep Amber	LEE 104	23	Med Blue	LEE 132	39	Halogen White	3200K
8	Orange	LEE 105	24	Congo Blue	LEE 181	40	Neutral White	4200K
9	Deep Golden Amber	LEE 135	25	Mikkel Blue	LEE 716	41	Daylight White	5600K
10	Yellow	LEE 101	26	Rose Pink	LEE 002	42	Cold White I	6000K
11	Green	100% Green LED	27	Med Pink	LEE 036	43	Cold White II	6300K
12	Lime Green	LEE 088	28	Light Lavender	LEE 052	44	Amber (only if available)	100% Amber LED
13	Moss Green	LEE 089	29	Lavender	LEE 058	45	Lime (only if available)	100% Lime LED
14	LEE Green	LEE 121	30	Magenta	LEE 113	46	Cyan (only if available)	100% Cyan LED
15	Primary Green	LEE 139	31	Mauve	LEE 126			
16	Jas Green	LEE 738	32	Smokey Pink	LEE 127			

### Quick Color\*

The standalone mode “Quick Color” allows a direct adjustment of the single LED segments, Dimmer and Shutter.

Level 1

Menu
DMX Mode
█ Stand Alone
Settings
System Info

Level 2

Stand Alone Mode
Stop Stand Alone
Auto FX
Color Macro
█ Quick Color
Tunable White
User Color
Color Settings
Master

Level 3

Quick Color	
Dimmer Center Tube	<0-100>
Dimmer Single Tubes	<0-100>
Dimmer RGB Panels	<0-100>
Shutter	<0-255>
Red	<0-255>
Green	<0-255>
Blue	<0-255>

To adjust your Quick Color please press ENTER to access to main menu (level 1).

While using the UP / DOWN arrows select the menu item “Stand Alone” and confirm

by pressing ENTER. After please select the item “Quick Color” by using the up/down arrows and press ENTER again.

Using UP and DOWN controls, select your desired LED segment or color and confirm with ENTER.

After you can adjust the brightness for the color between 000-255 and confirm by ENTER.

Besides the individual color mix also a master dimmer can be adjusted between 000-100.

For strobe effects please adjust the Shutter value between 000-255.

**ⓘ \*Note: Please see detailed explanation for strobe effects inside DMX chart at the end of this manual. Using UP/DOWN arrows at homescreen you can change Quick Color’s dimmer value.**

### Tunable White\*

The standalone mode “Tuneable White” allows the color temperature (CCT) to be adjusted from 2.000K – 10.000K in 100K steps and affects both RGB panels only. Besides brightness and shutter also a +/- green and magenta correction is available.

Level 1

Menu
DMX Mode
█ Stand Alone
Settings
System Info

Level 2

Stand Alone Mode
Stop Stand Alone
Auto FX
Color Macro
Quick Color
█ Tunable White
User Color
Color Settings
Master

Level 3

Tunable White	
CCT	<5600>
TINT	<000> (+/-127)
Dimmer	<0-255>
Shutter	<0-255>

Starting from home screen press ENTER to access to main menu (level 1).

While using the UP / DOWN arrows select the menu item “Stand Alone” and confirm by pressing ENTER.

After please select the item “Tunable White” by using the up/down arrows and press ENTER again.

Using UP and DOWN controls to select your desired menu item, confirm by ENTER and adjust the desired value by up and down controls and confirm all entries with ENTER.

**ⓘ \*Note:**

**Tint values**

- 000** = no function/neutral
- 001 - 127** = + green
- 001 to - 127** = - green

**ⓘ \*Note: Using UP/DOWN arrows at homescreen the selected CCT value can be changed in +/- 100K steps.**

**Shutter: Please see detailed explanation for strobe effects inside DMX chart at the end of this manual.**

**User Color\***

The standalone mode “User Color” allows to store up to 5 customized color presets out of Red, Green, Blue, brightness and shutter.

Level 1

Menu
DMX Mode
➤ Stand Alone
Settings
System Info

Level 2

Stand Alone Mode
Stop Stand Alone
Auto FX
Color Macro
Quick Color
Tunable White
➤ User Color
Color Settings
Master

Level 3

User Color
Color 1
Color 2
Color 3
Color 4
Color 5

Level 4

User Color
Dimmer <0- <b>100</b> >
Shutter <0- <b>255</b> >
Red < <b>0</b> -255>
Green < <b>0</b> -255>
Blue < <b>0</b> -255>

To define a User Color please press ENTER to access to main menu (level 1).

While using the UP / DOWN arrows, please select the menu item “Stand Alone” and confirm by pressing ENTER.

Select the item menu “User Color” by using the up/down controls and press ENTER.

Using UP and DOWN select your desired preset number (Color 1 -5) and confirm with ENTER.

Use UP and DOWN controls to select your desired color, confirm by ENTER and adjust the value by up and down controls between 000-255 and confirm all entries with ENTER.

With dimmer you can adjust the allover brightness of your User Color. Shutter allows several strobe effects. Once your color mix is ready, jump back by ESC. Your individual color is stored under the selected color preset now.

**ⓘ \*Note: All five User Colors are also available by DMX at Color Macro channel.**

**For detailed information please see Color Macro Chart at the end of this manual.**

**Using UP/DOWN arrows at homescreen the Color Macros can be changed according to the list.**

**Shutter: Please see detailed explanation for strobe effects inside DMX chart at the end of this manual.**

### Color Settings\*

Here at "Color Settings" you can chose your preferred working color mode for all Stand Alone modes. Either Color Calibration or RAW. Chose Color Calibration if the fixture should work accroding to the settings at Color Calibration, either Full Calibration or CCT Calibration, RAW works according to the settings at RAW Balance, either RAW or User Calibrated.

Level 1

Menu
DMX Mode
➤ Stand Alone
Settings
System Info

Level 2

Stand Alone Mode
Stop Stand Alone
Auto FX
Color Macro
Quick Color
Tunable White
User Color
➤ Color Settings
Master

Level 3

Color Settings
➤ <b>Color Calibration</b>
RAW

### Master

If you want to set up a Master-Slave-System, select "On" at the fixture, that should be the Master and controls all connected Slaves. Keep this "Off", if you don't need it to prevent DMX collisions.

Level 1

Menu
DMX Mode
➤ Stand Alone
Slave
Settings
System Info

Level 2

Stand Alone Mode
Stop Stand Alone
Auto
Color Macro
Quick Color
Tunable White
User Color
Color Settings
➤ Master

Level 3

Master
On
➤ <b>Off</b>

### 5.4.5 Settings

Level 1

Menu
DMX Mode
Stand Alone
➤ Settings
System Info

Main Menu	Menu level 2	Menu level 3	Menu level 4	Menu level 5	Menu level 6	Remark
DMX Mode	<ul style="list-style-type: none"> <li>• 15CH Simple</li> <li>• 39CH Easy</li> <li>• 71CH Standard</li> <li>• 112CH Pure</li> <li>• 209CH Pure Mode Access</li> <li>• 178 CH Full Access Extended</li> </ul>					
Stand Alone	Stop Stand Alone					
	Auto FX	<b>Stop Program</b>				
		Dimmer <0-100>				
		Speed <0-100> (default 50)				
		Effect 1				
		Effect 2				
		Effect 3				
		Effect 4				
		Effect 5				
		Effect 6				
		Effect 7				
		Effect 8				
	Effect 9					
	Effect 10					
	Color Macro (affects both RGB Panels)	Color Off				
		Dimmer <0-100>				
		Color macros 1-46 (Reference to Stand Alone Color Macro chart)				
	Quick Color	Dimmer Center Tube <0-100>		affects Center CW Tube only		
		Dimmer Single Tubes <0-100>		affects 4x single CW Tubes		
		Dimmer RGB Panels <0-100>		affects both RGB Panels		
		Shutter <0-255>		affects all		
		Red <0-255>		affects both RGB Panels		
		Green <0-255>		affects both RGB Panels		
	Blue <0-255>		affects both RGB Panels			

Main Menu	Menu level 2	Menu level 3	Menu level 4	Menu level 5	Menu level 6	Remark	
Stand Alone	Tunable White (affects both RGB Panels)	Dimmer <0-100>					
		Shutter <0-255>					
		CCT <2000K-10.000K> <b>(default 5600K)</b>	adjustable in 100K steps				
		Tint <000> +/-127	0= no function 001--127 plus green -001 to -127 plus magenta				
	User Color (affects both RGB Panels)	Color1	Dimmer<0-100>				
		Color2	Shutter <0-255>				
		Color3	Red <0-255>				
		Color4	Green <0-255>				
		Color5	Blue <0-255>				
	Color Settings (affects Stand Alone Modes only)	Color Calibration	Working accrodg to the settings at Color Calibration, either Full Calibration or CCT Calibration.				
		RAW Balance	Working accrodg to the settings at RAW Balance, either RW or User Calibrated.				
Master	on/off						
Settings	Protocol	<b>DMX</b>				enables DMX protocol	
		Art-Net				enables Art-Net protocol	
		sACN				enables sACN protocol	
		Slave				confirm with ENTER, after Slave Mode is activated Display will show Slave Mode. Connect the master and slave units (same model) with a DMX cable and enable one of the stand-alone modes on the master unit (Auto, Quick Color).	
	Ethernet	Art-Net	IP Address		xxx.xxx.xxx.xxx		IP address: 1. Set block, confirm, Set 2nd block, confirm
		sACN	Subnet Mask		xxx.xxx.xxx.xxx		Subnet Mask: 1. Set block, confirm, Set 2nd block, confirm
			Universe		000-254		Sets the Universe
			Universe Group		000-127		Sets the Universe Group
			Send Current Universe to DMX		On / Off		On: passes current Universe to DMX Out Off: doesn't pass current Universe to DMX Out



Main Menu	Menu level 2	Menu level 3	Menu level 4	Menu level 5	Menu level 6	Remark
Settings	Display	Display Flip <on/off>	On= Flip control panel display by 180° (e.g. for overhead installation) Off= normal control panel display			
		Backlight <on/off>	On= controls permanent on , display itself will deactivate after 60 minutes of inactivity Off= controls and display deactivation after approximately 1 minute of inactivity			
		Auto Lock <on/off>	On= Automatically locks the controls after approximately 1 minute of inactivity. After attempted input the display shows: "Locked!" Unlock process: press arrows up, down, up, down consecutively			
	Startup Mode (using last adjustments of Stand-alone Modes)	<b>DMX / Art-Net / sACN</b>	Select your default operating mode when fixture is powered on			
		Auto				
		Color Macro				
		Quick Color				
		Tunable White				
		User Color (User Color 1-5)				
	DMX Fail	<b>Hold</b>	Hold= last command retains			
		Blackout	Blackout= Activates Blackout			
		Emergency Light	Emergency Light= Fixtures changes to 5600K			
	Dimmer Curve	<b>Linear</b>	Linear= Light intensity increases linear with DMX value			
		Exponential	Exponential= Light intensity can be set more smooth at lower DMX values and broadly at higher DMX values.			
		Logarithmic	Light intensity can be broadly adjusted at lower DMX values and more smooth at higher DMX values			
		S-Curve	Light intensity can be adjusted smoothly at lower and higher DMX values and broadly at medium DMX values			
	Dimmer Response	<b>LED (Fast)</b>	The LED responds abruptly to DMX value changes at brightness			
		Medium	The LED responds with medium delay to DMX value changes at brightness			
		Halogen (Slow)	The LED responds similar to a halogen fixture with soft changes at brightness.			

Main Menu	Menu level 2	Menu level 3	Menu level 4	Menu level 5	Menu level 6	Remark	
Settings	Color Calibration (affects Calibrated DMX modes and Stand Alone)	Full Calibration	Calibration on RGB Panels for CCT & Colors				
		<b>CCT Calibration</b>	Calibration on RGB Panels on CCT only, RAW Colors				
	RAW Balance (affects DIRECT DMX modes and Stand Alone)	<b>RAW</b>					R,G,B with maximum value of brightness
		User Calibration	Red	<0-255>			individual color calibration of R,G,B for each single eye
			Green	<0-255>			
	Blue		<0-255>				
	LED Frequency	800 Hz	Select preferred LED PWM frequency				
		<b>1200 Hz</b>					
		2000 Hz					
		3600 Hz					
		12000 Hz					
		25000 Hz					
	Fan	<b>Auto</b>	Adjust fan speed relative to internal fixture temperature				
		Silent	Low fan speed for silent operation				
		Fan Off	Fan Off				
		Max. Power	High fan speed for maximum cooling effect				
	Invert / Swap Mapping	RGB Panel 1	On / <b>Off</b>				Inverts the pixel layout of the fixture
		RGB Panel 2	On / <b>Off</b>				Inverts the pixel layout of the fixture
		Centric Tube	On / Off				Inverts the pixel layout of the fixture
		Single Tube 1	On / <b>Off</b>				Inverts the pixel layout of the fixture
		Single Tube 2	On / <b>Off</b>				Inverts the pixel layout of the fixture
		Single Tube 3	On / <b>Off</b>				Inverts the pixel layout of the fixture
Single Tube 4		On / <b>Off</b>				Inverts the pixel layout of the fixture	
Swap RGB Panels		On / <b>Off</b>				Swaps the RGB Panels of the fixture	
Swap Single Tubes		On / <b>Off</b>				Swaps the Single Tubes 1+2 / 3+4 of the fixture	
Transfer Configuration	Including DMX Address	<b>Without DMX Address</b>	Transfer the same menu settings of this fixture to all the other in daisy chain (same model), either with DMX address or without. After power off and on again, the transferred settings should stay the same.				

Main Menu	Menu level 2	Menu level 3	Menu level 4	Menu level 5	Menu level 6	Remark	
Settings	LED Mode	Illumination	Normal output for constant illumination				
		<b>Boost</b>	Boost for temporarily highest output for blinder and strobe effects				
	USB Update	Yes	Run firmware update via USB port / keeps the current DMX Address				
		<b>No</b>	Do not run firmware update via USB port				
	Factory / User Reset	Factory Reset	Are you sure to reset? Confirm by pressing ENTER, cancel with ESC	Select your User Reset defaults		Note: Factory Reset by Menu sets DMX address back to 1 and DMX mode back to default mode  Factory Reset by DMX / RDM keeps current DMX address and DMX mode	
		User Reset	Are you sure to reset? Confirm by pressing ENTER, cancel with ESC			Restores all User Reset according to the User Preset List. DMX address restore to Factory default. Once User Reset is activated a fixture self test will start while dimming in and out every single LED and eye and fan. Self Test is not available while activating User Rest by DMX Settings.	
	Factory / User Reset	User Reset List	15CH Simple, 31CH Easy, 64CH Standard, 112CH Pure, 209CH Pure Mode 168 CH Full Access, 265CH Full Access Extended				
			Color Settings < <b>Factory Calibration</b> , RAW>				
			Protocol < <b>DMX</b> /Art-Net/sACN/				
			Display Flip <on/off>				
			Backlight <on/off>				
			Auto Lock <on/off>				
			Startup Mode < <b>DMX</b> , Art-Net, sACN, Auto,Color Macro, Quick Color, Tunable-White, User Color >	Select your User Reset defaults			
DMX Fail < <b>Hold</b> /Blackout/Emergency>							
Dimmer Curve < <b>Linear</b> , Exponential, Logarithmic, S-Curve>							
Dimmer Response < <b>LED</b> , Medium, Halogen>							
Color Calibration <Full Calibration/ <b>CCT Calibration</b> >							

Main Menu	Menu level 2	Menu level 3	Menu level 4	Menu level 5	Menu level 6	Remark
Settings	Factory / User Reset	User Reset List	RAW Balance <RAW/User Calibrated>	Select your User Reset defaults		
			LED Frequency <800Hz, <b>1200Hz</b> , 2000Hz, 3600Hz, 12000Hz, 25000Hz>			
			Fan < <b>Auto</b> , Silent, Fan Off, Max. Power>			
			Transfer Configuration <including DMX address / <b>without DMX address</b> >			
			LED Mode <Illumination, <b>Boost</b> >			
			USB Update <yes/ <b>no</b> >			
System Info	Firmware Version	vx.xx				Display installed firmware version
	Serial Number	202042200001				
	RDM UID	0X6a6ahxxxxxxx				
	Temperatures	Celsius LED : XXX°C or Fahrenheit LED : XXX °F"	LED RGB Panels & Single Tubes			Display RGB Panels temperature by celsius or fahrenheit
			LED Centric Tube			Display Centric CW Tube temperature by celsius or fahrenheit
	Power on Time	Total:xxxxxhours				Display fixture total power on time
	LED on Time	LED RGB Panels & Single Tubes	Total:xxxxxhours		Display LED RGB Panels total power on time	
		LED Centric Tube	Total:xxxxxhours		Display LED Centric CW Tube total power on time	
	Errors	Errors information				Display error codes
Fan Speed					Display the current fan speed	

## Dimmer Curves

LINEAR

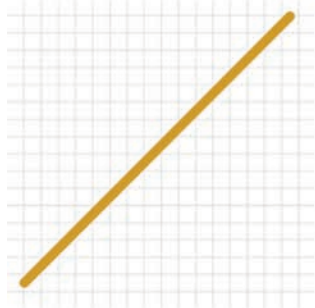

EXPONENTIAL

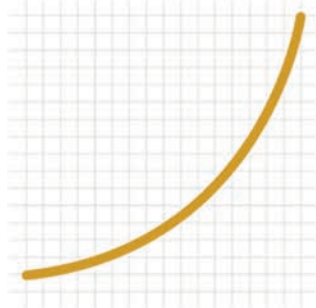

LOGARITHMIC



S-CURVE



### 5.4.6 System Info

Level 1

Menu
DMX Mode
Stand Alone
Slave
Settings
➤ System Info

Main Menu	Menu level 2	Menu level 3	Menu level 4
System Info	Firmware Version	vx.xx	Display installed firmware version
	Serial Number	209xxxxxxxx	
	RDM UID	0X6a6ahxxxxxxxx	Display unique RDM ID for identification
	Temperatures	Celsius LED: XXX°C or Fahrenheit LED: XXX°F	LED RGB Panels & Single Tubes LED Centric Tube
	Power on Time	Total: xxxxxhours	Display fixture total power on time
	LED on Time	LED RGB Panels & Single Tubes LED Centric Tube	Total: xxxxxhours
	Errors	Errors information	Display error codes

## 6. ACCESSORIES



Pre-installed elliptical  
horizontal filter  
Art.: 13907824



Pre-installed elliptical  
vertical filter  
Art.: 13907924



Omega Bracket STi,  
white  
Art.: 90900025



Omega Bracket STi,  
black  
Art.: 90900026

## 7. TECHNICAL DATA / DIAGRAMS

### 7.1 Technical drawings and measurements

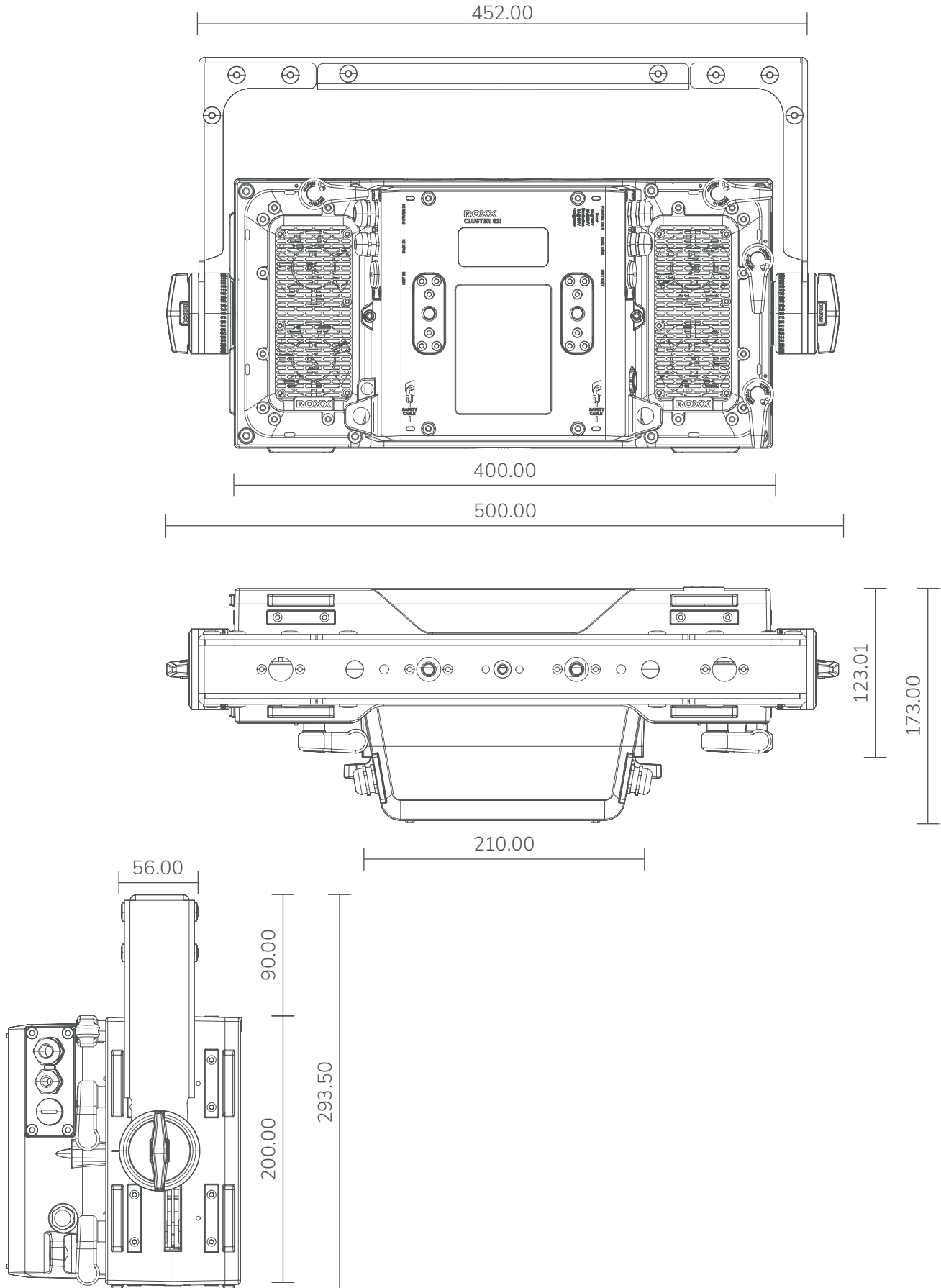

## 7.2 IP Rating

ROXX products conform to officially classified IP standard levels. CLUSTER S2i is rated to IP66 when using the covers for the housing parts. IP stands for Ingress Protection and IP66, according to classified standard, means shielded against dust and high-pressure jets of water from any side.

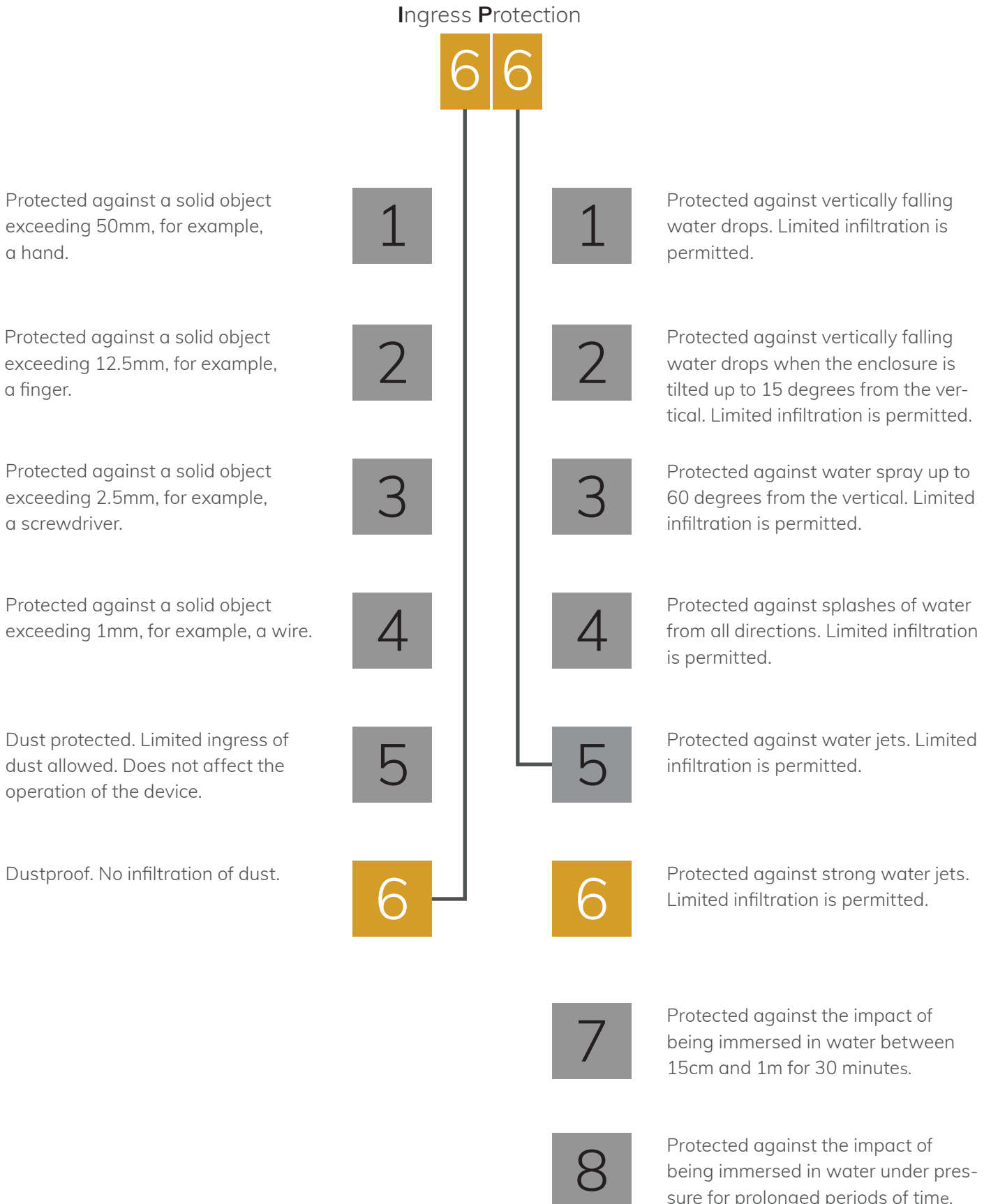



### 7.3 Technical Data

Photometrics	
LED expected lifetime	50.000 hours
Lightsource	612x CW LED's (7000K), 680x RGB LED's
Type of optical system	native, elliptical lens
LED PWM Frequency	selectable 800Hz, 1.200Hz, 2.000Hz, 3.600Hz, 12kHz, 25kHz
Beam angles @ Full (50%)	66°
Maximum Field angles @ Full (10%)	108°
Color temperature range	2000-10.000K
CRI/Ra @ Full	88
Efficacy @ Full (max)	48,07 lm/W
Luminous flux @ Full	57.750 lm (1200W)
Luminous flux @ Full (illumination mode)	14.807lm (305W)
Luminous flux @ Center Strobe (Boost Mode)	70.661lm (1135W)
Luminous flux @ 4x Single Strobes (Boost Mode)	35.582lm (982W)
Luminous flux @ 2x RGP Panels (Boost Mode)	22.685lm (853W)
Luminous flux @ Center Strobe (Illumination Mode)	20.260lm (300W)
Luminous flux @ 4x Single Strobes (Illumination Mode)	14.480lm (300W)
Luminous flux @ 2x RGP Panels (Illumination Mode)	7.920lm (300W)
illuminance Lux @ 3m / 9,84ft (@ Full)	4460lx / 414fcd
illuminance Lux @ 3m / 9,84ft (@ Center Strobe )	3500lx / 325fcd
illuminance Lux @ 3m / 9,84ft (@ 4x Single Strobes)	2560lx / 238fcd
illuminance Lux @ 3m / 9,84ft (@ Center Strobe + 4x Single Strobes)	4045lx / 376fcd
illuminance Lux @ 3m / 9,84ft (@ 2x RGB Panels)	1075lx / 100fcd
Thermal Characteristics	
Cooling	Active, Forced Air, Temperature-regulated
Humidity (max.)	95%
Temperature range, Operating	-40°C to 45°C
Temperature range, Start-Up	-20° to 45°C
Temperature range, Storage	-40°C to 80°C
Thermal Protection	Automatic overtemperature protection
Electrical Data	
AC Power, max	90 – 285V 50/60Hz
AC Power, nominal	100 – 240V 50/60Hz
Electrical protection	Overload protection with automatic recover
Max power consumption	1250W
Constant power consumption (Illumination Mode)	320W
Power Max. Out	14A @ 230V / 13A @ 120V
Power Linking @ Max Power Consumption (Boost Mode)	0 unit @ 120V / 1 unit @ 230V
Power Linking @ Constant Power Consumption (Illumination Mode)	4 units @ 120V / 11 units @ 230V
Power Factor	0.998 PF (230V) / 0.997 PF (120V)
Power Supply Unit	Inbuilt auto-ranging electronic switch-mode

### 7.3 Technical Data

Operator & Controller	
DMX channels	Simple Mode 15CH, Easy Mode 39CH, Standard Mode 71CH (default mode), Pure Mode 112CH Single Pixel 8 Bit with Strobefunction, Pure Mode 209CH Single Pixel 16 Bit with Strobefunction, Full Access Mode 178CH 8 Bit single Pixel with Pattern, Full Access Extended Mode 275CH 16 Bit with Pattern
DMX modes	7
Protocol	USITT DMX512A
	RDM ANSI E1.20
	Art-Net
	sACN
Setting and addressing	OLED graphical display / 4 controls
	RDM ANSI E1.20
Standalone mode	Auto Program, Color Macro, Quick Color, Tunable White, User Color
Wireless DMX	n.a.
Indicator	OLED graphical display
Controls	4 touch sensitive, backlighted controls
Strobe	0-30Hz
DMX I/O	PG9 cable gland with 3m cable, open end
Ethernet I/O	PG9 cable gland with sealing cap, RJ45 I/O sockets installed inside
Power In	PG11 cable gland with 3m cable, open end
USB Firmware Update	n.a.
Dimensions & Weight	
IP class	IP66
IK class	IK08
Body material	Aluminum, Nylon, Stainless Steel
Lens material	Tempered glass front
Net dimensions without Yoke (w x h x d)	400 x 200 x 191mm
Net dimensions inches	15,75 x 7,87 x 7,52 inches
Net weight (incl. Yoke)	12,6 kg (27,78lbs)
Tilt	360°
Tilt Locking System	Locking system with tooting and angle indicator
Included / Optional	
Included items	Yoke 4.1, Puk
Optional Accessories	Multiple in-built filters, Yoke 2.2, Yoke 4.3, Yoke Floor Extension, Rigging Bracket, Omega Bracket STIT
Color options	White – RAL 9010 C5H coated (Standard) / Custom color – any RAL (on request)
Installation	
Mounting point by Yoke (included)	3x 13mm / 1/2" holes, 1x centric TV Spigot attachment
Mounting point on fixture	M10 on top and rear side
Mounting point with optional Rigging Bracket	2x 13mm / 1/2" holes for Clamp fixation
Orientation	Any
Rigging possibilities	Hanging or ceiling / pendant mount
Safety features	2x rear mount for safety wire
Minimum distance from flammable materials	0,3 meters (11,8 inch)

## 7.4 DMX-Charts / Color Macro Charts / CCT Chart

**15CH Simple Mode**

**39CH Easy Mode**

**72CH Standard Mode (default)**

**112CH Pure Mode**

**209CH Pure Mode**

**178CH Full Access Mode**

**275CH Full Access Extended Mode**

Here you can find the DMX charts and Pattern Charts for the CLUSTER S2i for reading or downloading. Simply click on the icon or scan the QR code.

DMX charts

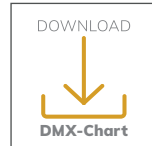

Pattern charts



Gels - Color Macros for DMX		
DMX value	Gel Name	Color Number
000-005	no function	
006-008	Red	100% Red LED
009-011	Fire	LEE 019
012-014	Medium Red	LEE 027
015-017	Primary Red	LEE 106
018-020	Med Amber	LEE 020
021-023	Dark Amber	LEE 022
024-026	Deep Amber	LEE 104
027-029	Orange	LEE 105
030-032	Deep Golden Amber	LEE 135
033-035	Yellow	LEE 101
036-038	Green	100% Green LED
039-041	Lime Green	LEE 088
042-044	Moss Green	LEE 089
045-047	LEE Green	LEE 121
048-050	Primary Green	LEE 139
051-053	Jas Green	LEE 738
054-056	Jade	LEE 323
057-059	Blue	100% Blue LED
060-062	Sky Blue	LEE 068
063-065	Tokyo Blue	LEE 071
066-068	Light Blue	LEE 118
069-071	Marine Blue	LEE 131
072-074	Med Blue	LEE 132
075-077	Congo Blue	LEE 181
078-080	Mikkel Blue	LEE 716
081-083	Rose Pink	LEE 002
084-086	Med Pink	LEE 036
087-089	Light Lavender	LEE 052
090-092	Lavender	LEE 058

Gels - Color Macros for DMX		
093-095	Magenta	LEE 113
096-098	Mauve	LEE 126
099-101	Smokey Pink	LEE 127
102-104	Special Med Lavender	LEE 343
105-107	Ultimate Violet	LEE 707
108-110	Magical Magenta	LEE 795
111-113	Chrysalis Pink	LEE 798
114-116	Specia KH Lavender	LEE 799
117-119	Bulb White	2700K
120-122	Halogen White	3200K
123-125	Neutral White	4200K
126-128	Daylight White	5600K
129-131	Cold White I	6000K
132-134	Cold White II	6300K
135-137	White (only if available)	100% White LED
138-140	Amber (only if available)	100% Amber LED
141-143	Lime (only if available)	100% Lime LED
144-146	Cyan (only if available)	100% Cyan LED
147-149	User Color 1	
150-152	User Color 2	
153-155	User Color 3	
156-158	User Color 4	
159-161	User Color 5	
162-164	Color Jumping stop	
165-209	Color Jumping speed slow @ fast	color 1-37
210-255	Color fading speed slow @ fast	color 1-37

Color Macro Chart for Stand Alone

Gels - Color Macros for Standalone Mode		
Position	Gel Name	Color Number
1	Red	100% Red LED
2	Fire	LEE 019
3	Medium Red	LEE 027
4	Primary Red	LEE 106
5	Med Amber	LEE 020
6	Dark Amber	LEE 022
7	Deep Amber	LEE 104
8	Orange	LEE 105
9	Deep Golden Amber	LEE 135
10	Yellow	LEE 101
11	Green	100% Green LED
12	Lime Green	LEE 088
13	Moss Green	LEE 089
14	LEE Green	LEE 121
15	Primary Green	LEE 139
16	Jas Green	LEE 738
17	Jade	LEE 323
18	Blue	100% Blue LED
19	Sky Blue	LEE 068
20	Tokyo Blue	LEE 071
21	Light Blue	LEE 118
22	Marine Blue	LEE 131
23	Med Blue	LEE 132
24	Congo Blue	LEE 181
25	Mikkel Blue	LEE 716
26	Rose Pink	LEE 002
27	Med Pink	LEE 036
28	Light Lavender	LEE 052

Gels - Color Macros for Standalone Mode		
Position	Gel Name	Color Number
29	Lavender	LEE 058
30	Magenta	LEE 113
31	Mauve	LEE 126
32	Smokey Pink	LEE 127
33	Special Med Lavender	LEE 343
34	Ultimate Violet	LEE 707
35	Magical Magenta	LEE 795
36	Chrysalis Pink	LEE 798
37	Specia KH Lavender	LEE 799
38	Bulb White	2700K
39	Halogen White	3200K
40	Neutral White	4200K
41	Daylight White	5600K
42	Cold White I	6000K
43	Cold White II	6300K
44	Amber (only if available)	100% Amber LED
45	Lime (only if available)	100% Lime LED
46	Cyan (only if available)	100% Cyan LED

CTC channel  
DMX / Color temperature

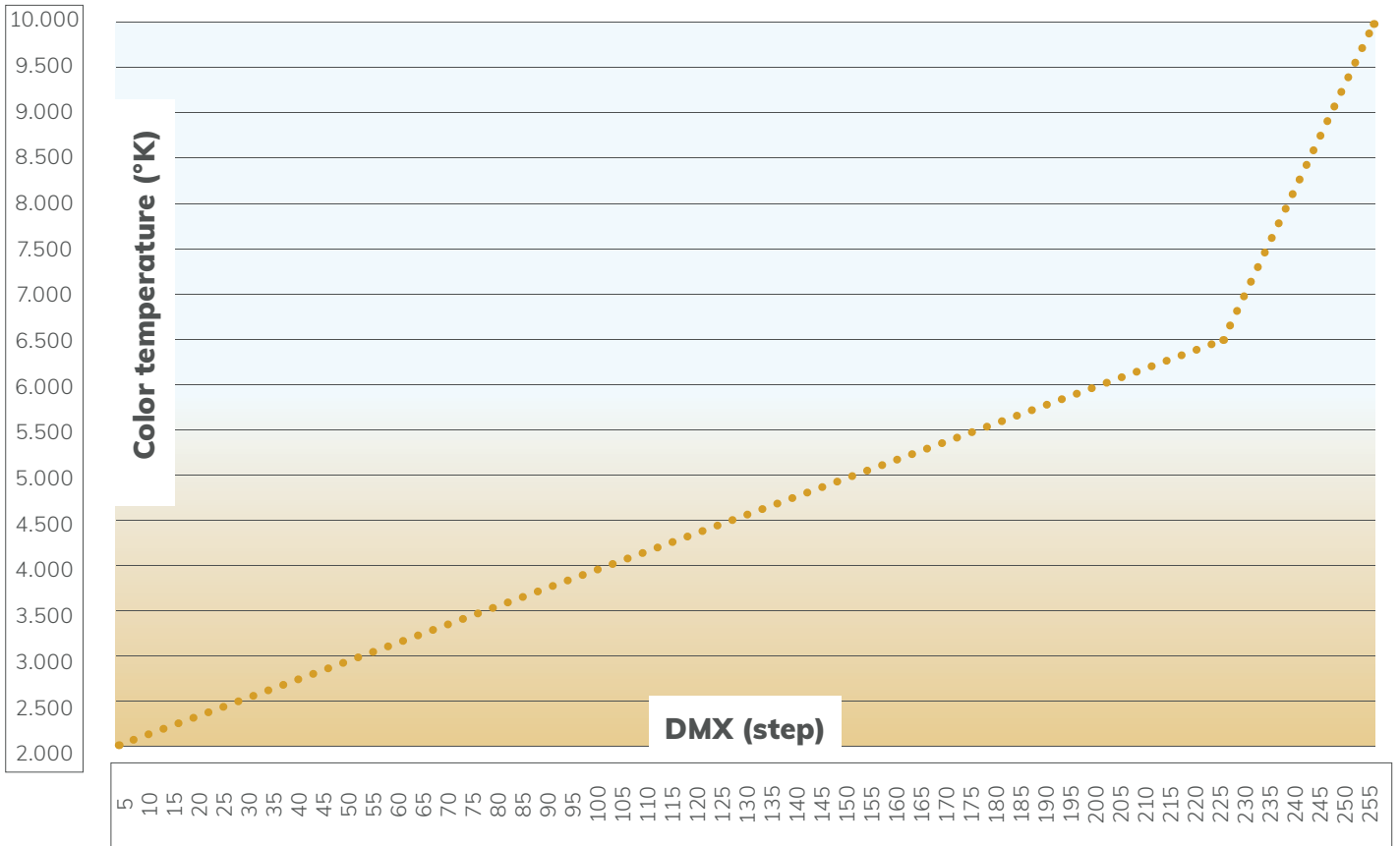

CTC-Chart

DMX (Step)	Color Temp (°K)	DMX (Step)	Color Temp (°K)	DMX (Step)	Color Temp (°K)	DMX (Step)	Color Temp (°K)	DMX (Step)	Color Temp (°K)	DMX (Step)	Color Temp (°K)
0	7000	43	2774	86	3649	129	4525	172	5400	215	6276
1	7000	44	2794	87	3670	130	4545	173	5421	216	6296
2	7000	45	2814	88	3690	131	4566	174	5441	217	6317
3	7000	46	2835	89	3710	132	4586	175	5462	218	6337
4	7000	47	2855	90	3731	133	4606	176	5482	219	6357
5	2000	48	2876	91	3751	134	4627	177	5502	220	6378
6	2020	49	2896	92	3771	135	4647	178	5523	221	6398
7	2041	50	2916	93	3792	136	4667	179	5543	222	6419
8	2061	51	2937	94	3812	137	4688	180	5563	223	6439
9	2081	52	2957	95	3833	138	4708	181	5584	224	6459
10	2102	53	2977	96	3853	139	4729	182	5604	225	6480
11	2122	54	2998	97	3873	140	4749	183	5624	226	6500
12	2143	55	3018	98	3894	141	4769	184	5645	227	6621
13	2163	56	3038	99	3914	142	4790	185	5665	228	6741
14	2183	57	3059	100	3934	143	4810	186	5686	229	6862
15	2204	58	3079	101	3955	144	4830	187	5706	230	6983
16	2224	59	3100	102	3975	145	4851	188	5726	231	7103
17	2244	60	3120	103	3995	146	4871	189	5747	232	7224
18	2265	61	3140	104	4016	147	4891	190	5767	233	7345
19	2285	62	3161	105	4036	148	4912	191	5787	234	7466
20	2305	63	3181	106	4057	149	4932	192	5808	235	7586
21	2326	64	3201	107	4077	150	4952	193	5828	236	7707
22	2346	65	3222	108	4097	151	4973	194	5848	237	7828
23	2367	66	3242	109	4118	152	4993	195	5869	238	7948
24	2387	67	3262	110	4138	153	5014	196	5889	239	8069
25	2407	68	3283	111	4158	154	5034	197	5910	240	8190
26	2428	69	3303	112	4179	155	5054	198	5930	241	8310
27	2448	70	3324	113	4199	156	5075	199	5950	242	8431
28	2468	71	3344	114	4219	157	5095	200	5971	243	8552
29	2489	72	3364	115	4240	158	5115	201	5991	244	8672
30	2509	73	3385	116	4260	159	5136	202	6011	245	8793
31	2529	74	3405	117	4281	160	5156	203	6032	246	8914
32	2550	75	3425	118	4301	161	5176	204	6052	247	9034
33	2570	76	3446	119	4301	162	5197	205	6072	248	9155
34	2590	77	3466	120	4342	163	5217	206	6093	249	9276
35	2611	78	3486	121	4362	164	5238	207	6113	250	9397
36	2631	79	3507	122	4382	165	5258	208	6133	251	9517
37	2652	80	3527	123	4403	166	5278	209	6154	252	9638
38	2672	81	3548	124	4423	167	5299	210	6174	253	9759
39	2692	82	3568	125	4443	168	5319	211	6195	254	9879
40	2713	83	3588	126	4464	169	5339	212	6215	255	10000
41	2733	84	3609	127	4484	170	5360	213	6235		
42	2753	85	3629	128	4505	171	5380	214	6256		

## 7.5 RDM Templates\*

The ROXX Show series features support for various RDM functions.

RDM (Remote Device Management) is a protocol enhancement to USITT DMX512 that allows bi-directional communication between the fixtures and the controller over a standard DMX line. This protocol will allow configuration, status monitoring and management.

You will need a RDM controller to get control over the supported parameters. See the tables below for supported RDM features.

Label:	ROXX CLUSTER S2i
Model:	CLUSTER S2i
Manufacturer:	ROXX
ID:	6A6Ah
Device ID:	209 xxxx

**ⓘ \*Note: During RDM identifying process CLUSTER S2i flashes white to blue color alternately.**

### RDM functions

For easy identifying ROXX CLUSTER S2i during RDM process the unit will jump from white color to blue color every second.

PID	Function	Action	Values
0x00F0	DMX Start Adress	Set	001-512
0x00E0	DMX Personality	Set	7 x DMX Modes
0x00E1	DMX Slots	Read	n.a.
0x0500	Display Flip	Set	0= On / 1= Off
0x8051	Display Backlight	Set	0= Off / 1= On
0x8052	Display Lock	Set	0= Off / 1= On
0x8001	Effect	Set	tba
0x8002	Effect Dimmer	Set	0-100
0x8003	Effect Speed	Set	0-100
0x8062	Protocol	Set	tba
0x8053	Startup Mode	Set	0= DMX / 1= AUTO / 2= Color Macro / 3= Quick Color / 4= Tunable White / 5=User Color
0x8060	Color Settings	Set	0= Color Calibration / 1= RAW
0x8054	DMX Fail	Set	1= Hold / 2= Blackout / 3= Emergency
0x8055	Dimmer Curve	Set	1= Linear / 2= Exponential / 3= Logarithmic / 4= S-Curve
0x8056	Dimmer Response	Set	1= LED / 2= Medium / 3= Halogen
0x8061	Color Calibration	Set	0=CCT Calibration / 1= Full Calibration
0x8058	RAW Balance	Set	0= RAW / 1= User Calibration
0x8101	User Calibration - Red	Set	0-255
0x8102	User Calibration - Green	Set	0-255
0x8103	User Calibration - Blue	Set	0-255
0x8059	LED Frequency (PWM)	Set	1= 800Hz / 2= 1200Hz / 3= 2000Hz / 4= 3600Hz / 5= 12kHz / 6=25kHz
0x805A	Fan	Set	0= Auto / 1= Silent / 2= Fan Off / 3= Max. Power
0x8063	Invert Mapping RGB Panel1	Set	0= Off / 1= On
0x8064	Invert Mapping RGB Panel2	Set	0= Off / 1= On

PID	Function	Action	Values
0x8065	Invert Mapping Centric Tube	Set	0= Off / 1= On
0x8066	Invert Mapping Single Tube 1	Set	0= Off / 1= On
0x8067	Invert Mapping Single Tube 2	Set	0= Off / 1= On
0x8068	Invert Mapping Single Tube 3	Set	0= Off / 1= On
0x8069	Invert Mapping Single Tube 4	Set	0= Off / 1= On
0x806A	Invert Mapping Swap RGB Panel	Set	0= Off / 1= On
0x806B	Invert Mapping Swap Single Tubes	Set	0= Off / 1= On
0x805C	LED Mode	Set	0= Illumination / 1= Boost
0x805E	Factory Reset	Set	0= No / 1= Yes
0x805F	User Reset	Set	0= No / 1= Yes
0x00C0	Firmware Version	Read	n.a.
0x8700	Serial Number	Read	n.a.
0x0400	Device Power on Time	Read	n.a.
0x8701	Temperature LED RGB Panels & Single Tubes	Read	n.a.
0x8702	Temperature LED Centric Tube	Read	n.a.
0x8705	LED on Time RGB Panels	Read	n.a.
0x8706	LED on Time Centric Tube	Read	n.a.
0x8707	LED on Time Single Tubes	Read	n.a.
0x8709	Fan Speed	Read	n.a.

## Sensors

RDM enables various readouts for remote device monitoring. See the table below for sensors and sensor types. Please note: The RDM controller communicates with the fixtures to show only the available sensors for this fixture. The table is subject to change without notice.

Name	
Temperature	xx°C / xxx°F
Software Version	SW-Version
Errors	

## 7.6 Firmware Updating

Here you can find the Firmware Update Instructions for reading or downloading. Simply click on the icon or scan the QR code.





## 8. TROUBLESHOOTING

Did you try turning the device off and on again?

Problem	Reason	Solution
Device is not responding.	No power.	Check cable connections and conform that power is switched on.
	Fuse defect.	Contact your qualified service technician / manufacturer.
Device has turned off.	Power failure or power was turned off.	Check power supply, fuse, connections, switches.
Device has stopped responding.	DMX cable correct?	Check cables.
Device operates strangely.	DMX cable inverted (pins correct?)	Use a phase inverter or different cables.
	DMX cable terminated?	If not, install DMX termination at the end of the cable.
	Stand Alone program running?	Stop internal Stand Alone.

## 9. MANUFACTURER'S DECLARATION

### Manufacturer's Warranty & Limitations of Liability

Please find our warranty conditions and limitations of liability inside our manufacturer's declaration at [www.roxxlight.com/support](http://www.roxxlight.com/support)

### Requesting Warranty-Service

To request warranty service for your product, please contact:

ROXX GmbH,  
Hansestr. 91  
51149 Köln

Email: [info@roxxlight.com](mailto:info@roxxlight.com) or the ROXX authorized reseller in your country, from where you purchased your product.

### Correct Disposal of this product



This is for the European Union and European countries with electrical waste collection systems. When this label is shown on the product or brochure it means that the item cannot be disposed with household waste. In order to prevent damage to the environment or human health please do not dispose this product uncontrolled. Make sure to act responsible, recycle this product separately from other types of waste to enable lasting reuse of resources. Private users please contact the retailer where you purchased this product or your local authorities to find out where and how proper recycling of this item is possible. Business users please contact your supplier or check the terms and conditions of your purchasing contract. Make sure not to mix this product with other commercial waste.

## FCC Statement

This device complies with Part 15 of the FCC Rules. Operation is subject to the following two conditions:

- (1) This device may not cause harmful interference, and
- (2) This device must accept any interference received, including interference that may cause undesired operation

NOTE: This equipment has been tested and found to comply with the limits for a Class B digital device, pursuant to Part 15 of the FCC Rules. These limits are designed to provide reasonable protection against harmful interference in a residential installation. This equipment generates, uses and can radiate radio frequency energy and, if not installed and used in accordance with the instructions, may cause harmful interference to radio communications. However, there is no guarantee that interference will not occur in a particular installation. If this equipment does cause harmful interference to radio or television reception, which can be determined by turning the equipment off and on, the user is encouraged to try to correct the interference by one or more of the following measures:

- Reorient or relocate the receiving antenna.
- Increase the separation between the equipment and receiver.
- Connect the equipment into an outlet on a circuit different from that to which the receiver is connected.
- Consult the dealer or an experienced radio/TV technician for help.

## CE Compliance

The equipment marketed by ROXX GmbH complies (where applicable) with the essential requirements and other specifications of the following Directives:

- 2014/30/EU (EMC)
- 2014/35/EU (LVD)
- 2011/65/EU (RoHS)

The complete EU- and UK-Declaration of Conformity can be found at [www.roxxlight.com/support](http://www.roxxlight.com/support), or you can also request it at [info@roxxlight.com](mailto:info@roxxlight.com)

