

# FUSION

by GLP

## Fusion EXO Wash 30

### User Manual

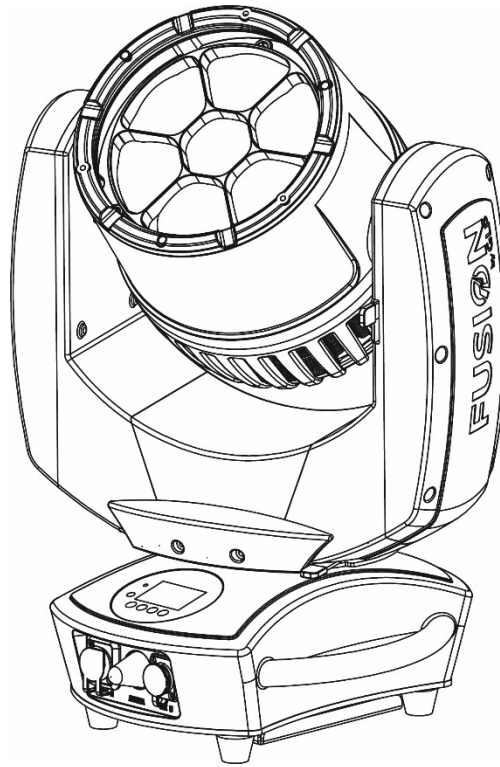

Software version V1.0.00



GLP® Fusion EXO Wash User Manual – Revision B

This document covers fixture software version V1.0.00

---

© 2019 German Light Products GmbH. All rights reserved.

The marks 'GLP' and 'German Light Products' are trademarks registered as the property of German Light Products GmbH in Germany, in the United States of America and in other countries.

The information contained in this document is subject to change without notice. German Light Products GmbH and all affiliated companies disclaim liability for any injury, damage, direct or indirect loss, consequential or economic loss or any other loss occasioned by the use of, inability to use or reliance on the information contained in this document.

Manufacturer's head office:

German Light Products GmbH (GLP), Industriestrasse 2, 76307 Karlsbad, Germany  
Tel (Germany): +49 7248 92719 - 0

Service & Support EMEA:

GLP, Industriestrasse 2, 76307 Karlsbad, Germany  
Tel. (Germany): +49 7248 9271955  
Email: [support@glp.de](mailto:support@glp.de)  
[www.glp.de](http://www.glp.de)

Service & Support USA:

GLP USA, 1145 Arroyo St., Ste. A, 91340 San Fernando, California  
Tel (USA): +1 818 767 8899  
Support (US): [info@germanlightproducts.com](mailto:info@germanlightproducts.com)  
[www.germanlightproducts.com](http://www.germanlightproducts.com)

## Table of Contents

1.	Safety .....	5
	Key to symbols .....	5
	General safety information .....	5
	Electrical safety .....	6
	Fire safety and protection from burns.....	7
	Eye safety .....	8
	Strobe safety .....	8
	Installation safety and protection from personal injury .....	9
2.	Avoiding damage to the fixture .....	10
	General precautions.....	10
	Avoiding damage from light sources and heat .....	10
	IP rating.....	11
	Avoiding damage from water and humidity.....	11
	Avoiding damage from dust and airborne particles.....	12
	Transportation and storage.....	12
	GLP Service and Support.....	12
3.	EXO Wash 30 overview .....	13
4.	Installation.....	15
	Permitted mounting options .....	15
	Securing fixtures with a safety cable .....	15
	Installing on a rigging truss or similar structure.....	16
	Standing on a horizontal surface .....	17
5.	AC mains power .....	18
	Included items .....	18
	Connecting to power .....	18
	Installing power connectors.....	19
	Connecting multiple fixtures to power in a chain .....	19
6.	Connecting to DMX data.....	20
7.	Starting and stopping operation .....	21
8.	Features .....	22
	Position.....	22
	Color .....	22
	.....	22
	Dimming .....	23
	Strobe / shutter .....	23
	Zoom .....	23
	Behavior when the fixture is not receiving a DMX signal .....	23
9.	Control menus and onboard display .....	24
	Display options.....	25
	Display Locking .....	25
	Manual Control.....	25
	LED PWM frequency.....	25

Fan control .....	25
Fixture information .....	25
Pan disable / Tilt disable .....	26
Preset settings and factory defaults.....	26
10. Control menu layout .....	27
Service Advanced menu .....	29
11. DMX control modes overview.....	30
12. DMX control channel layout tables.....	33
DMX Mode 1: Compact .....	33
DMX Mode 2: Standard .....	35
DMX Mode 3: Extended .....	39
13. Service .....	48
Cleaning.....	48
GLP Service and Support.....	48
14. Technical specifications .....	49
Optics.....	49
Control .....	49
Installation .....	49
Electrical .....	49
Connections.....	49
Construction.....	49
Thermal .....	49
Included items .....	50
Dimensions and weight .....	50
15. Dimensions.....	51

## 1. Safety

### Key to symbols

The following symbols are used in the Fusion EXO Wash 30 lighting fixture's user documentation:



**Warning!** Safety hazard.  
Risk of severe injury or death.



**Warning!** Hazardous voltage.  
Risk of lethal or severe electric shock.



**Warning!** See user manual for important safety information.



**Warning!** Fire hazard.



**Warning!** Risk of eye injury.

---



### General safety information

**Read this manual carefully before installing, using or servicing the Fusion EXO Wash 30 lighting fixture.**

If you have any doubts or questions about how to use the fixture safely, contact your GLP® supplier for assistance. Your GLP supplier will be happy to help.

The user documentation for GLP Fusion EXO Wash 30 lighting fixtures consists of:

- This document, the **EXO Wash 30 User Manual**, supplied with the fixture and available for download from [www.glp.de](http://www.glp.de). The User Manual contains important safety information and installation instructions that the installer and user must read.
- The **EXO Wash 30 DMX Channel Index**, available for download from [www.glp.de](http://www.glp.de). The Channel Index is a separate guide to the DMX control channel layout and DMX commands available.

All documents are available for download from [www.glp.de](http://www.glp.de).

The Fusion EXO Wash 30 is intended for use by experienced professionals with the knowledge and skills to set up, operate, and maintain high-powered, remotely controlled lighting equipment safely and efficiently. These operations require expertise that may not be provided in this Manual or in the User Manual.

- Respect all warnings and directions given in the fixture's user documentation and on the fixture. Read the user documentation and familiarize yourself with the safety precautions it contains before installing or using the fixture. GLP and affiliated

companies will take no responsibility for damage or injury resulting from disregard for the information in the user documentation.

- Check the GLP website at [www.glp.de](http://www.glp.de) and make sure that you have the latest version of this manual. Check the fixture software version indicated on page 2 of this manual and then use the fixture's control panel to check the version installed in the fixture. If the versions are not the same, this manual may still cover the fixture, because software updates do not always affect the way you use the fixture. However, it is possible that this manual does not match the fixture perfectly. Software release notes can help clarify this question. You can consult software release notes and download the correct version of this manual on the GLP website if necessary.
- Make all user documentation available to all installers and operators. Save this document for future reference.
- If you have any questions about the safe operation of the fixture, please contact an authorized GLP distributor (see list of distributors at [www.glp.de](http://www.glp.de)).
- Use the fixture only as directed in this manual. Observe all markings in this manual and on the fixture.
- Refer all repairs and any service operation not described in this manual to a technician authorized by GLP.
- The light source in this fixture must not be changed by the end user.
- Read and follow the user documentation for all additional equipment.



### **Electrical safety**

- Do not allow the fixture to become immersed. Do not expose the fixture to high-pressure water projections.
- Keep any unused connectors on the fixture sealed with their protective caps at all times, both when the fixture is in use and when not in use.
- Use only a source of AC mains power that complies with local building and electrical codes and has both overload and ground fault (earth fault) protection.
- Ensure that the fixture is electrically connected to ground (earth).
- Disconnect the fixture from AC mains power before carrying out any installation or maintenance work and when the fixture is not in use.
- Disconnect the fixture from power immediately if any seal, cover, cable, connector or other component is damaged, defective, deformed or showing signs of overheating. Do not reapply power until the fixture has been repaired and made safe by a technician authorized by GLP.
- Check that all power distribution equipment, cables and connectors are in perfect condition, rated for the electrical requirements of all connected devices, suitable for their application and suitable for the installation environment.

- Use only Neutrik PowerCON TRUE1 cable connectors for AC mains power input at the fixture's Mains IN connector and for relaying AC mains power from one fixture's Mains OUT (Thru) connector to another fixture's Mains IN connector.
  - Use minimum 14 AWG or 1.5 mm<sup>2</sup> power input and relay cables that are minimum 16 A-rated and temperature-rated to suit the application. In the USA and Canada the cables must be UL-listed, type SJT or equivalent. In the EU the cables must be type H05VV-F or equivalent.
  - Do not connect devices to power in a chain if the total maximum current draw of all the devices in the chain when added together will exceed the current rating of any cable or connector used at any point in the chain. The supplied power input cable is rated as follows:
    - US power cable: 16 A, 14 AWG, UL-listed, E304117, SJT, 4.9 ft.
    - EU power cable: 16 A, 1.5 mm<sup>2</sup>, H07RN-F, 1.5 m.
- Do not connect more than four (4) Fusion EXO Wash 30 fixtures to power in a chain at 100-120 V, 60 Hz.
- Do not connect more than eight (8) Fusion EXO Wash 30 fixtures to power in a chain at 200-240 V, 50 Hz.
- The voltage and frequency at the Mains OUT socket are the same as the voltage and frequency applied to the Mains IN socket. Only connect devices to the Mains Out socket that accept this voltage and frequency.
  - Fusion EXO Wash 30 fixtures do not have a user-replaceable fuse. If you suspect that a fuse has blown, disconnect the fixture from power and send it to a technician authorized by GLP for repair.



### **Fire safety and protection from burns**

- Do not operate the fixture if the ambient temperature (Ta) exceeds 40° C / 104° F.
- The surface of the fixture's casing can reach up to 90° C / 194° F during operation. Avoid contact by persons and materials. Do not install the fixture in a location where there is a risk of accidental contact. Allow the fixture to cool for at least 20 minutes before handling
- Keep the fixture well away from flammable materials.
- Keep all combustible materials (e.g. fabric, wood, paper) at least 0.5 m / 20 in. away from the fixture.
- Ensure that there is free and unobstructed airflow around the fixture.
- Do not illuminate surfaces within 0.5 m / 20 in. of the fixture. The light output from the fixture is powerful enough to cause burns or fire in illuminated objects at very close range.
- Do not stick filters, masks or other materials onto the fixture. Do not block the light output in any way. The front surface becomes hot during operation and can melt or

ignite objects that are in contact with the surface. Ensure that the front surface is clean and unobstructed at all times in order to prevent a fire hazard and damage to the fixture.

- The fixture's optical components can focus the sun's rays, creating a risk of fire and damage. Do not expose the front of the fixture to sunlight or any other intense light source, even from an angle.



### **Eye safety**

- The EXO Wash 30 is classified as a Risk Group 3 lighting fixture according to EN 62471. Possibly hazardous radiation emitted. Do not stare into the light output from the fixture. May be harmful to the eyes.
- Do not look at the fixture's light output with optical instruments or any device that may concentrate the light output.
- Make sure that persons near to or working on the fixture are not looking directly into the light output when the fixture lights up suddenly. This can happen when power is applied, when the fixture receives a DMX signal, or when certain control menu items are selected.
- The warning below is printed on the fixture. If the warning becomes impossible to read, replace it with a label reproduced from this illustration:

**Risk Group 3 - WARNING**  
Possibly hazardous optical radiation from this product. Do not look at operating lamp. Eye injury may result!

- Provide well-lit conditions to reduce the pupil diameter of anyone working on or near the fixture.



### **Strobe safety**

- Flashing light, particularly at 5 - 30 Hz, may cause seizures in persons with photosensitive epilepsy. Do not use strobe effects for extended periods.
- Comply with local regulations on the use of strobe lighting and notify the public in advance with highly visible warning signs when strobe effects are used.
- If a seizure occurs, stop using strobe effects. Seek professional medical help. Note the time that the seizure starts and finishes. Call emergency medical help urgently if



the seizure lasts more than five minutes, if it is the person's first seizure, or if the person is injured. While waiting for help to arrive, protect the affected person from injuring themselves on hard or sharp objects. If necessary, move the person to a safe place. Lay them on their side with their head supported to prevent it from hitting the floor. Loosen any tight clothing around their neck. Do not use force to hold the person or restrict their movements. Do not put anything in their mouth, including your fingers.



### ***Installation safety and protection from personal injury***

- Installation must be performed by qualified personnel only and carried out in accordance with all locally applicable regulations such as DIN VDE 0711-217.
- The fixture is not portable when installed.
- Ensure that the supporting structure and installation hardware used can hold at least ten times the weight of the load that they support.
- Fasten the fixture to a structure or surface only as directed in this manual and only with hardware that is specifically designed and rated for its purpose. Do not use a safety cable as the primary means of support. Check that installation hardware is in perfect condition. Fasteners must be steel grade 8.8 strength or better. Rigging clamps must be half-coupler type that completely encircle the rigging truss chord.
- If the fixture is installed in a location where it may cause injury or damage if it falls, install as directed in this manual a safety cable or similar secondary attachment that will hold the fixture if a primary attachment fails. The secondary attachment must be approved by an official body such as TÜV as a safety attachment for the weight that it secures, it must comply with EN 60598-2-17 Section 17.6.6, and it must be able to support a static suspended load that is ten times the weight that it secures.
- If the fixture is installed in a location where it may be exposed to forces such as wind pressure, vibration or movement, make sure that the installation can withstand these forces. Monitor weather forecasts constantly. Take down the installation immediately if there is any risk of weather conditions that could destabilize the installation.
- Check that all covers and items of rigging hardware are secure before using the fixture. Do not operate the fixture with missing or damaged covers, shields or any optical component.
- Restrict access below the work area and work from a stable platform whenever installing, servicing or moving the fixture.
- If the fixture becomes damaged, stop using it immediately and disconnect it from power. Do not attempt to use a fixture that is obviously damaged.
- Do not modify the fixture in any way not described in its user documentation.
- Install genuine GLP parts only.

## 2. Avoiding damage to the fixture

**Important! Follow the directions in this section carefully, or the fixture may suffer damage that is not covered by the product warranty.**

### **General precautions**

Do not drop the fixture or expose it to mechanical stress.

Protect the onboard LCD display and control panel from shocks, or they may suffer damage that is not covered by the product warranty.

Do not expose the fixture to heat (from other lighting fixtures for example).

Clean optical components only as directed. Oils, solvents, and other chemicals commonly used for cleaning can damage the lens coatings and surfaces.

Use only original spare parts. Do not make any structural modifications to the fixture or you will void the product warranty.

### **Avoiding damage from light sources and heat**

Do not point the front of the fixture towards the sun or other strong light sources. Strong light can cause internal damage to the fixture, melting components or starting an internal fire within seconds.

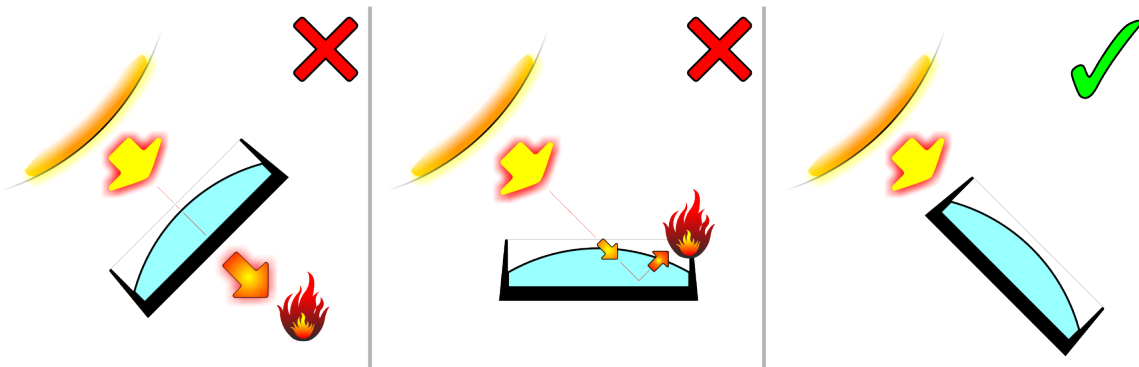

**Figure 1. Avoiding damage from light sources**

Damage can occur whether the fixture is powered on or off. See Figure 1. Damage can also occur if the light hits the front of the fixture at an angle: the fixture does not need to be pointing *directly* at the sun or other light source.

To avoid problems from strong light sources:

- Do not expose the front of the fixture to sunlight or any other strong light source.
- In outdoor applications during daylight, make sure that the front face of the fixture is shielded or points away from the sun, even when not in use.
- Do not aim other high-powered beam lights directly at the fixture.

Do not operate the fixture in ambient temperatures above 40° C / 104° F. Allow free airflow around the fixture.

## IP rating

EXO Wash 30 fixtures are IP65-rated:

- **IP** stands for Ingress (entry into the fixture) Protection.
- The first figure **6** in the rating means that fixtures are protected against the entry of dust and airborne particles.
- The second figure **5** in the rating means that fixtures are protected against the entry of rain and water projections from all angles. Fixtures are not protected against immersion in water and they are not protected against high-pressure water jets.

## Avoiding damage from water and humidity

- Do not install EXO Wash 30 fixtures in a location where water can pool around the fixture or allow EXO Wash 30 fixtures to become submerged in any other way. Do not aim low- or high-pressure water jets at fixtures.
- Keep all unused connectors on the fixture sealed with their protective caps, both when the fixture is being used and when it is not in use.
- In outdoor and high-humidity environments, use IP65-rated power and data connectors and cable (an IP65 rating means that the item is protected against the entry of water from rain, projections and low-pressure jets as well as the entry of dust). When assembling connectors and installing them on cable, follow the manufacturer's instructions (see [www.neutrik.com](http://www.neutrik.com)) and ensure that an IP65 rating is maintained for the complete assembly. Use only the following cable connectors:
  - IP65-rated 5-pin XLR connectors for data IN and OUT (THRU)
  - Neutrik powerCON TRUE1 NAC3FX-W for Power IN
  - Neutrik powerCON TRUE1 NAC3MX-W for Power OUT (THRU).
- Apply a dielectric grease (available from electrical suppliers) to connector terminals and caps to prevent corrosion and/or electrical short circuits.
- Make sure that cables open into dry areas or sealed junction boxes. Moisture can be drawn along cables by capillary action or pressure variations resulting from thermal expansion.
- See drawing on right.  
Arrange cables so that they arrive at connectors from below. Make sure that it is impossible for water to flow down cables and accumulate at connectors. If necessary, provide extra cable slack and create 'drip loops' before connectors.
- Create loose cable bends only. Do not subject connections to bending forces or allow connections to bear the weight of long lengths of cable.

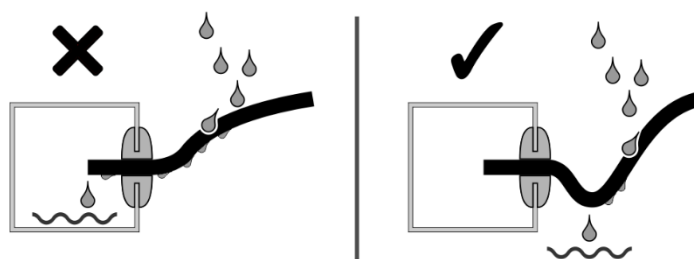

***Avoiding damage from dust and airborne particles***

- Carry out regular visual inspections of the fixture to make sure that there is no accumulation of dirt, especially on the front of the fixture.
- If cleaning is necessary, follow the instructions in 'Service' on page 48.

***Transportation and storage***

- Transport the fixture in its original packaging or a suitably designed flight case to protect it from damage caused by shocks during transportation.
- Release the tilt lock and support the fixture's head with the original packaging inserts or flight case inserts during transportation.
- Store the fixture in a dry location when not in use.

***GLP Service and Support***

Contact information for the nearest GLP Service and Support is available online at [www.glp.de/en/service](http://www.glp.de/en/service), by email at [info@glp.de](mailto:info@glp.de), or by telephone at the following numbers:

- GLP Germany: +49 (7248) 927 19-55
- GLP N. America: +1 818 767-8899
- GLP UK: +44 1392 690140
- GLP Asia: +852 (3151) 7730
- GLP Nordic: +46 737 57 11 40

### 3. EXO Wash 30 overview

The Fusion EXO Wash 30 from GLP is a powerful LED-based wash light fixture with fast pan and tilt, 4 to 54 degree variable zoom and seven independently controllable RGBW zones.

The fixture can be controlled by DMX or by settings on its built in color LCD control panel. An optional wireless DMX module can be fitted to enable LumenRadio wireless control. The fixture has a built-in battery to allow the display to be operated for setup before mains power is connected.

The EXO Wash 30 can be used indoors in permanent and temporary installations. Its rugged construction and IP65 rating mean that it can also be used outdoors in temporary installations if precautions are taken to prevent immersion in water and damage from direct sunlight. It can stand on a horizontal surface or be suspended from a suitable structure as described in Section 4.

The EXO Wash 30 is not suitable for household use, for use in any location where unattended children have access to it, or for use in permanent outdoor installations.

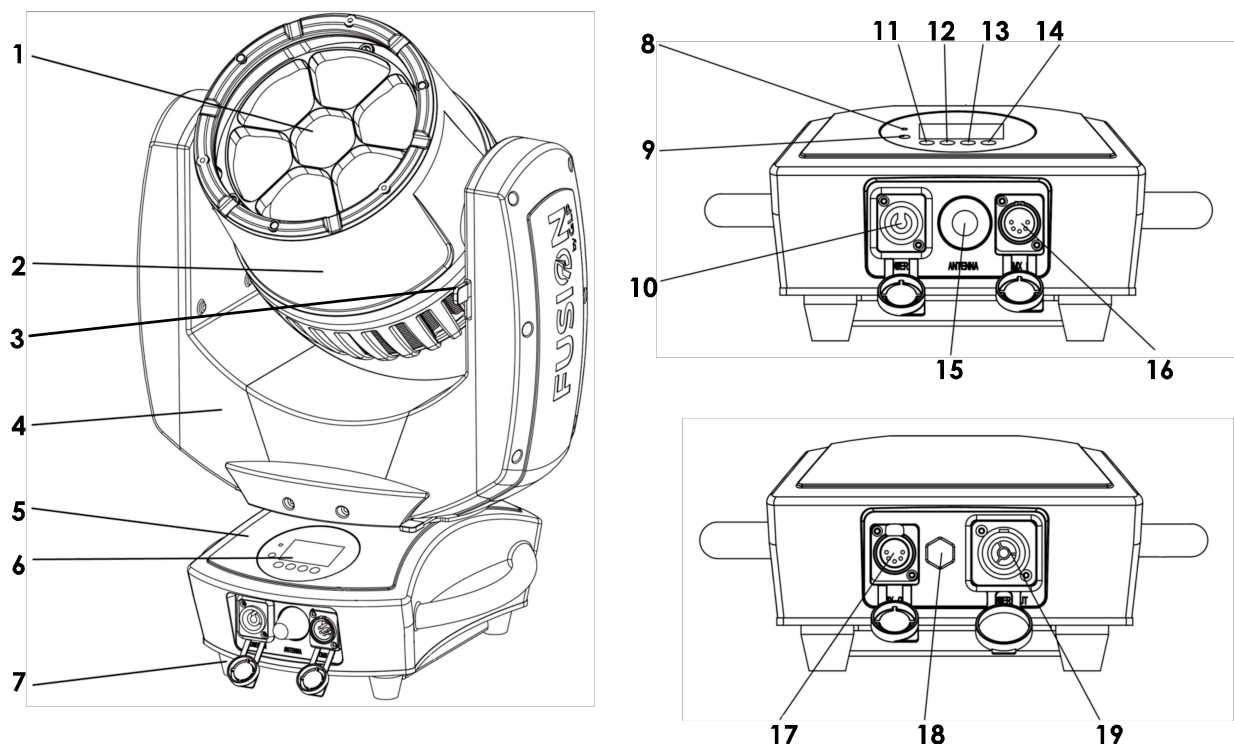

**Figure 2. EXO Wash 30 overview**

- |                          |                                       |
|--------------------------|---------------------------------------|
| <b>1 – Output lens</b>   | <b>8 – Wireless indicator</b>         |
| <b>2 – Head</b>          | <b>9 – Battery button</b>             |
| <b>3 – Tilt lock</b>     | <b>10 – PowerCON TRUE1 input</b>      |
| <b>4 – Yoke</b>          | <b>11 – Mode / Esc button</b>         |
| <b>5 – Base</b>          | <b>12 – Up button</b>                 |
| <b>6 – Control panel</b> | <b>13 – Down button</b>               |
| <b>7 – Rubber feet</b>   | <b>14 – Enter button</b>              |
|                          | <b>15 – Optional wireless antenna</b> |
|                          | <b>16 – 5 pin XLR DMX input</b>       |
|                          | <b>17 – 5 pin XLR DMX link out</b>    |
|                          | <b>18 – Vent valve</b>                |
|                          | <b>19 – PowerCON TRUE1 link out</b>   |

## 4. Installation



**Warning!** Read 'Safety' starting on page 5 for important safety information that you must understand before you install or operate the fixture. Install EXO Wash 30 fixtures only as described in this chapter, or you may create an installation that is unsafe.

Install the fixture at least 0.5 m / 20 in. away from combustible materials (wood, textiles, paper, etc.), 0.5 m / 20 in. away from any surface that will be illuminated, and a safe distance away from any flammable materials (volatile spirits, etc.).

It is the installer's responsibility to provide a stable, secure supporting structure that is suitable for the environment and application and that meets all applicable codes and legal requirements. Note the requirement to secure lighting fixtures with safety cables in temporary installations.

### ***Permitted mounting options***

An EXO Wash 30 fixture may be installed in one of the following ways:

1. Fastened to a rigging truss or similar structure at any angle by means of truss couplers or other clamps fixed to the two Omega brackets which attach to the half-turn couplers on the underside of the base.
2. Standing upright on the base on a horizontal surface.

### ***Securing fixtures with a safety cable***

In temporary installations, if a fixture can cause injury or damage if it falls you must secure it with a secondary attachment such as a safety cable that will hold it if the primary means of attachment fails. The safety cable must be approved for the weight that it secures. In multiple installations, each fixture must have its own safety cable.

To secure an EXO Wash 30 fixture with a safety cable:

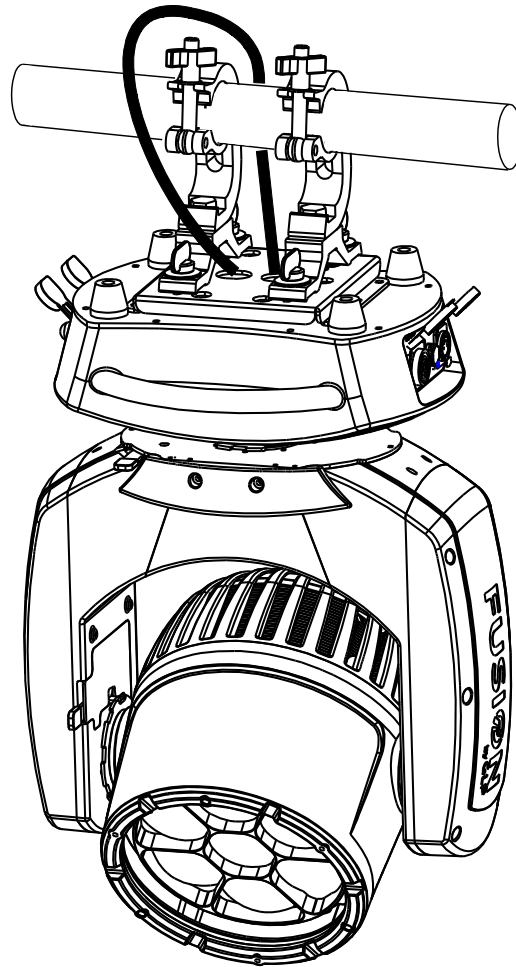

**Figure 3. Safety cable attachment**

1. Loop a safety cable around a secure anchoring point such as a truss beam or fixed structure so that it will catch the fixture if a rigging clamp fails. Take up as much slack as possible in the safety cable (by looping it more than once around the bar, for example).
2. See Figure 3 and Figure 4. Fasten the safety cable through the slot "B" on the underside of the fixture base. Check that the fixture is now secured.

### **Installing on a rigging truss or similar structure**

You can suspend an EXO Wash 30 fixture from a rigging truss or pipe using suitable clamps attached to the Omega Brackets supplied with the EXO Wash 30.

If you are going to install the fixture hanging vertically downwards from a horizontal rigging truss or pipe, you can fasten it to the truss using G-clamps. If you are going to install the fixture in any other orientation, you must use half-coupler clamps that completely surround the truss chord or pipe.



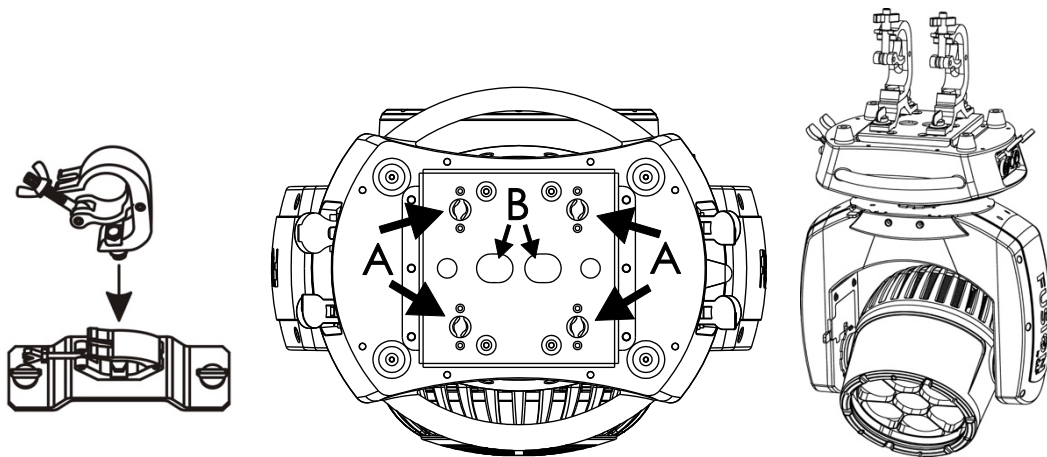

**Figure 4. Omega bracket fasteners**

1. Attach suitable clamps to the Omega brackets.
2. Line up the fasteners of the Omega bracket with the holes "A" in the base of the EXO Wash 30 as shown in Figure 4. The brackets may be installed either way round so the cabling is in line with the bar or at right angles to it.
3. Lock the Omega brackets onto the EXO Wash 30 by turning the fasteners through 90 degrees.
4. Attach the clamp to the truss or structure. Ensure that the head and yoke of the fixture will not collide with any fixed objects as the fixture moves. Ensure that the fixture has sufficient clearance to any adjacent surfaces or objects.
5. Secure the fixture with a safety cable through slots "B" as described in the previous section.

### **Standing on a horizontal surface**

To install an EXO Wash 30 fixture on a horizontal surface:

1. Check that the surface is secure and can safely hold the weight of the fixture plus all hardware and cables.
2. Stand the fixture firmly on the rubber feet fitted to the base of the unit. Ensure that the head and yoke of the fixture will not collide with any fixed objects as the fixture moves. Ensure that the fixture has sufficient clearance to any adjacent surfaces or objects.

## 5. AC mains power



**Warning!** Read 'Safety' starting on page 5 for important safety information that you must understand before you install or operate the fixture.

Check that all cables and connectors are suitable for the installation environment and application (see recommendations in 'Avoiding damage to the fixture' on page 10).

Use H07 RN-F 3 x 2.5mm / SJT 12 AWG cables with original Neutrik powerCON TRUE1 connectors to supply power to fixtures.

Line up the keyways in connectors carefully. Do not try to insert or twist a connector if it feels excessively stiff. Resistance to insertion or twisting is a sign that connectors may be incorrectly lined up.

Keep connectors sealed with their rubber caps at all times when not in use.

### **Included items**

The EXO Wash 30 is supplied with a power cord with Neutrik powerCON TRUE1 connector.

### **Connecting to power**

The AC mains power supply must include a connection to ground / protective earth. It must be protected against ground / earth leakage and overload. The fixture's internal auto-sensing power supply accepts AC power at 100-240 V, 50/60 Hz. Do not connect the fixture to power at any other voltage or to an external dimmer.

The EXO Wash 30 does not have a power ON/OFF switch. Power is applied to the fixture as soon as the power cable becomes live.

The EXO Wash 30 has a 3-conductor Neutrik powerCON TRUE1 Mains IN power input socket that accepts AC power from a TRUE1 female cable connector. Although TRUE1 connectors support hot plugging, it is still good practice to shut down power to power cables before connecting them to fixtures.

To connect the fixture to power:

1. If convenient, shut down power to the power input cable.
2. Note the position of the keys and keyways on the TRUE1 power cable connector and Mains IN socket and align them with each other. Insert the cable connector into the socket and twist clockwise to lock. Do not use force. If the connector feels excessively stiff, remove it and check again that it is lined up correctly.
3. Before applying power to the power cable, check that nobody is looking directly into the front of the fixture.

To disconnect the fixture from power, pull the latch on the cable connector outwards to release it, then twist the connector counterclockwise and pull to remove it from the socket.

## Installing power connectors

If you intend to draw power from convenience receptacles / consumer mains power sockets, it is possible to install a suitable cord cap / power plug on the supplied power cord / input cable. If you do this, check that the cord cap / plug is rated minimum 250 V, 16 A, that it has a connection to ground / earth and that it has an integral cable grip. Follow the cord cap / plug manufacturer's assembly instructions.

If you need to install a Neutrik powerCON TRUE1 connector on a power cable, follow the instructions given in the Support area of the Neutrik website at [www.neutrik.com](http://www.neutrik.com).

Respect the color coding used in the supplied power cable and in your local mains power wiring system. US and EU systems use the color coding shown below:

	Live or L	Neutral or N	Ground / Earth or ⊕
<b>US system</b>	Black	White	Green
<b>EU system</b>	Brown	Blue	Yellow/green

## Connecting multiple fixtures to power in a chain

You can connect fixtures to power in a daisy-chain to simplify your power circuit layout.

EXO Wash 30 fixtures have 2.5 mm<sup>2</sup> internal wiring from Power IN to Power THRU connectors.



**Warning!** Do not connect more than four (4) EXO Wash 30 fixtures in total to power in one chain at 100-120 V, 60 Hz. Do not connect more than eight (8) EXO Wash 30 fixtures in total to power in one chain at 200-240 V, 50 Hz.

The power input cable supplied with the fixture is rated 16 A maximum. Add together the maximum current draw ratings of all the devices that you intend to connect to power in a daisy chain and do not create a chain with a total maximum current draw of more than 16 A, or you will create a risk of fire and electric shock.

To connect fixtures to power in a chain:

1. Obtain power relay cables that have male and female Neutrik powerCON TRUE1 connectors. Cables must be minimum 14 AWG or 1.5mm<sup>2</sup>, rated minimum 16 A and suitable for the environment and application.
2. Connect the power input cable to the Mains IN socket of the first fixture as described under 'Connecting to power' on page 18.
3. Connect a relay cable to the Mains OUT / THRU socket of the first fixture and to the Mains IN socket of the second fixture.
4. If you are using 100-120 V, 60 Hz AC mains power you can continue connecting EXO Wash 30 fixtures Mains OUT / THRU socket to Mains IN socket until the chain contains a maximum of four (4) fixtures in total. If you are using 200-240 V, 50 Hz AC mains power you can continue connecting fixtures Mains OUT to Mains IN until the chain contains a maximum of eight (8) fixtures total.

## 6. Connecting to DMX data

Check that all cables and connectors are suitable for the installation environment and application (see recommendations in 'Avoiding damage to the fixture' on page 10).

Use digital 110 Ohm DMX cable with IP65 5-pin XLR connectors to supply DMX data to fixtures.

Keep connectors sealed with their rubber caps at all times when not in use.

The EXO Wash 30 has two 5-pin XLR sockets for IN and THRU connections to a DMX data link. EXO Wash 30 fixtures support the USITT DMX 512A signal protocol. They also support RDM (Remote Device Management).

The 5-pin XLR connectors use standard pin allocations:

1	Signal Ground
2	Data -
3	Data +
4	Not used
5	Not used

The DMX cable should start at the console and be daisy-chained through each fixture to be controlled using the DMX input and DMX link out connectors. If you need to split the DMX cable, use a powered DMX splitter.

If you would like advice with planning and installing a DMX link, your GLP supplier will be happy to provide assistance.

## 7. Starting and stopping operation



**Warning!** Before you apply power to the fixture or operate it after a blackout, make sure that nobody is looking directly into the front of the fixture.

The EXO Wash 30's TRUE1 mains power input connector supports hot-plugging, and connecting and disconnecting a live power cable is an option, especially if you need to shut down power urgently, but it is still good practice to shut down power to the AC mains power circuit before connecting and disconnecting power cables.

To start operation, check that nobody is looking into the front of the fixture, then apply power to the AC mains power circuit.

To stop operation, shut down power to the AC mains power circuit.

## 8. Features

The EXO Wash 30 unit has the following features:

### **Position**

Pan rotation 630°(3.9 sec) or 540°(4.3 sec), Tilt rotation 267°(2.2 sec) with 16 bit resolution. The fixture will automatically reposition if knocked – this option can be disabled from the menu. The Pan and Tilt movements can be inverted using the menu.

### **Color**

The fixture has seven zones of Red/Green/Blue/White (RGBW) color mixing LEDs. Depending on the DMX mode these have up to 16-bit dimming and can be controlled independently, or using macro patterns.

The zones/pixels are arranged as shown in the diagram below.

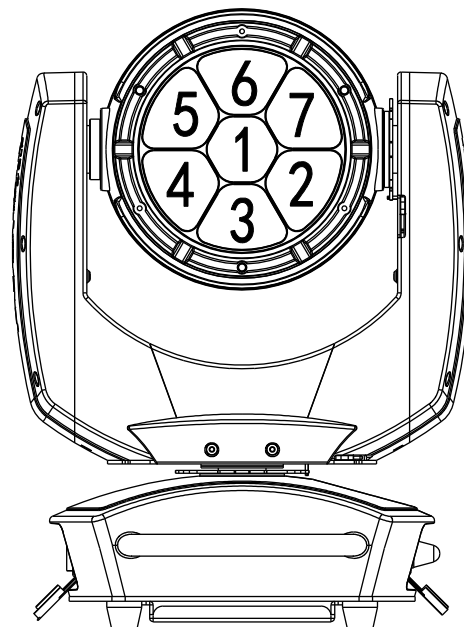

**Figure 5. Pixel order**

## Dimming

See Figure 6. You can select from two dimming curves using the control panel or the *Control / Settings* DMX channel:

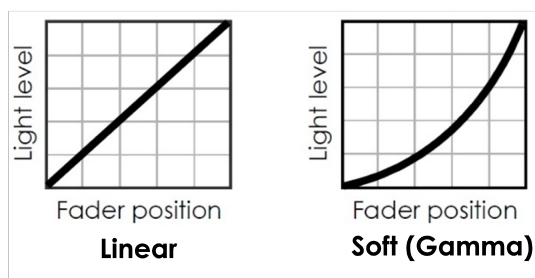

**Figure 6. Dimming curves**

- **Linear** sets dimming so that it appears to increase and decrease evenly throughout the dimming range.
- **Soft** gives finer control at low light levels and coarser control at high light levels.

The default setting is **Soft**.

## Strobe / shutter

A variety of strobing and fading effects can be produced by the fixture.

## Zoom

The beam angle of the fixture can be adjusted (zoom) from 4° to 54°. The zoom operation can be inverted using the menu.

## Behavior when the fixture is not receiving a DMX signal

You can set the fixture to react in three different ways if no DMX signal is present (if the fixture is being controlled by DMX but the DMX signal stops, or if you apply power to the fixture when no DMX signal is present):

- **Blackout** sets the fixture to black out. This is the default setting.
- **Hold** sets the fixture to continue obeying the last DMX values it received. If no DMX signal was being received, the fixture will black out.
- **Preset Scene** sets the fixture to output a preset scene which you have previously captured from an incoming DMX state using the Manual Control > Capture Scene menu option. You can also manually set the control values (or edit the captured values) using the attribute settings in the Manual Control menu.

All these settings are available via DMX on the *Control / Settings* channel and in the fixture's control panel.

## 9. Control menus and onboard display



**Warning!** DMX control is disabled when the control menus are active. Be prepared for the fixture to emit strong light as soon as you exit the control menus.

The control panel and onboard LCD display provide access to user settings, readouts and utilities.

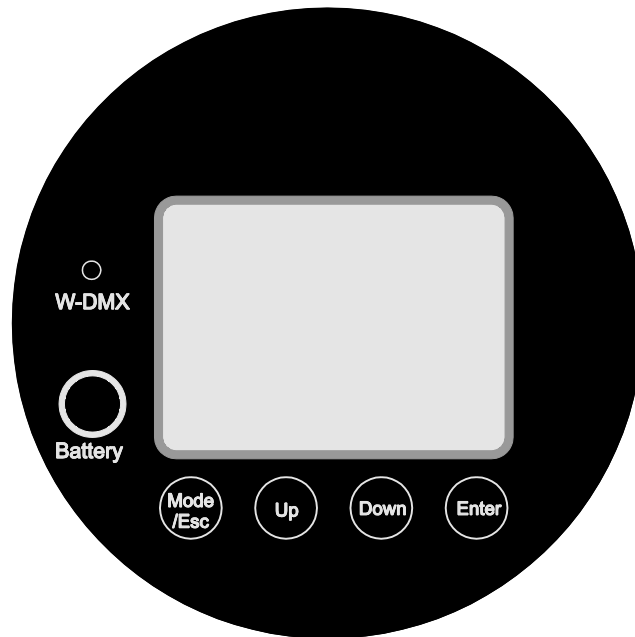

**Figure 7. Onboard display**

The four control buttons have the following functions:

**MODE/ESC:** Activate the menus or go back one level towards the top of the menu.

**UP:** Scroll up or increase a number.

**DOWN:** Scroll down or reduce a number.

**ENTER:** Activate the control panel if it is in sleep mode. Then enter a menu, select a setting or implement a command.

When you apply power to the fixture, it boots up. After it has booted, the panel displays the default screen.

The **Battery** button is used to power up the control panel for setup before mains is connected to the unit. Battery mode can be disabled in the menu.

The **W-DMX** indicator shows when wireless DMX is being received, if the optional wireless module has been fitted.



DMX control is disabled when the control menus are active.

## **Display options**

The illuminated LCD display lets you change fixture settings. The display has a battery backup so that you can change the settings before mains is connected to the fixture. See Chapter 9 for more details.

Using the *Control / Settings* DMX channel or the fixture's control panel you can:

Set **display modes** using the *Fixture Settings > Display Mode* option:

- **On:** The display stays on constantly. This setting can be useful when you are configuring or servicing the fixture.
- **Auto:** The display will automatically switch off after a few seconds even if the fixture is not receiving a valid control signal or if it has detected an error.

**Invert the display** using the *Fixture Settings > Display Orientation* option, so it is easier to read if the fixture is hanging upside down.

## **Display Locking**

On the *Fixture Settings > Lock* menu, you can configure the display to lock after a period of time to prevent accidental changes to the options.

You can set a custom lock code using the *Fixture Settings > Lock > Set Passcode* option. If you do not set a custom code, the default code is 0000.

## **Manual Control**

Using the *Manual Control* menu you can set fixed values to the fixture's control channels, as if it was in DMX control mode 1. This is useful when testing.

## **LED PWM frequency**

The LEDs in the unit are dimmed using Pulse Width Modulation (PWM) which can sometimes cause flickering on cameras. The *Fixture Settings > PWM* option allows you to select different frequencies for the PWM to fix such issues. The higher frequencies may cause reduced dimming performance.

## **Fan control**

The fixture has internal cooling fans. In a noise critical situation you can slow these down using the *Fixture Settings > Fan Mode* option. The normal setting is *Regulated* which will adjust the fan speed automatically. If you set the option to *Low* the fan speed is kept slow but this may result in the fixture overheating and reducing its output.

The fixture has an additional fan near the lens to clear condensation. You can control how this fan works using the *Fixture Settings > Defog* option.

## **Fixture information**

The **Information** menu in the control panel gives access to items of information from the fixture's sensors and memory. You can check temperature sensor readouts, see total operating hours counters, and see software version number, for example.

### ***Pan disable / Tilt disable***

These options allow you to disable the startup reset movements or disable the drive of the pan and/or tilt motors. The options are

- **Off:** Normal motor control
- **Reset Disabled:** The fixture will not do its power on reset sequence on this motor but the motor is still controlled. This can be used when a fixture is mounted in a confined space and would collide with an obstruction if it did the reset sequence.
- **Current Disabled:** The motor drive function is completely disabled. This is mostly used for service or diagnostics.

### ***Preset settings and factory defaults***

You can store three different versions of option settings using the *Service > Service Advanced > Save Settings* menu and load them using the *Load Settings > Preset 1-2-3* options. These allow you to quickly set up the fixture in a particular configuration. Settings are stored after a power off/on cycle and after a reset.

Two options are available in the fixture's control panel for deleting multiple custom settings and restoring defaults:

- **Service > Default Settings** reloads all the fixture's factory default settings **except** DMX address, DMX mode, captured scene, preset settings and offset values. This option returns the fixture to baseline settings without affecting its basic configuration in an installation.
- **Service > Service Advanced > Factory Backup** reloads all the fixture's factory default settings **including** DMX address, DMX mode, and erases all storage. This option reinitializes the fixture completely and returns to its state when it left the factory.
-

## 10. Control menu layout

Menus		Notes	
DMX ADDRESS	1 - 512	Enter DMX address	
CONTROL MODE	<b>Compressed</b> – 13 channels	Select DMX control mode	
	Standard – 22 channels		
	Extended – 37 channels		
	Pixel – 50 channels		
CONTROL PROTOCOL	<b>DMX</b>	Wired DMX control	
	WIRELESS	Wireless DMX control (optional module)	
FITTURE SETTINGS	Pan Invert	<b>Off</b> / On	Invert Pan movement
	Tilt Invert	<b>Off</b> / On	Invert Tilt movement
	Position Feedback	Off / <b>On</b>	If On, fixture repositions if knocked
	Pan Disabled	<b>Off</b> / Reset Disabled / Current Disabled	Disable motor drive for service
	Tilt Disabled	<b>Off</b> / Reset Disabled / Current Disabled	
	Zoom Invert	<b>Off</b> / On	Inverts Zoom movement
	Dimmer Curve	<b>Soft (Gamma)</b> / Linear	Dimming curve
	No Signal	<b>Blackout</b> / Hold / run Captured Scene	Action when no DMX signal
	Capture Scene	Press ENTER to capture scene	Store scene for no signal
	PWM	600 Hz / 2200 Hz / <b>3000 Hz</b> / 4800 Hz / 9600 Hz / 25000 Hz	Frequency of LED dimming
	Display Mode	<b>Auto</b> / On / Off	Display blanking
	Display Orientation	<b>Normal</b> / Upside Down	Display reversing
	Max Temperature	60 – <b>90C</b> / 140-194F	Sets overheat temperature where shutdown will occur
	Fan Mode	<b>Regulated</b> / High / Medium / Low	Set fan speed control
	Load Settings	<b>Preset 1</b> / Preset 2 / Preset 3	Press ENTER for 3 sec to confirm
	Lock	<b>Off</b> / On /. Set Passcode	Lock the control panel
	Defog	Off / <b>On</b> / Quick	Settings for lens defogging fan
Battery	<b>On</b> / Off	Disable the battery operation of the control panel	
MANUAL CONTROL	Reboot		Press ENTER for 3 sec to confirm
	Manual function control (DMX Mode 1)	Pan Coarse 0-255	These values can be set manually or from a DMX state using Capture Scene option
		Pan Fine 0-255	
		Tilt Coarse 0-255	
		Tilt Fine 0-255	
		Dimmer 0-255	
		Shutter 0-255	
Virtual color wheel 0-255			

		Red 0-255	
		Green 0-255	
		Blue 0-255	
		White 0-255	
		Zoom 0-255	
		Control 0-255	
	Capture Scene		<i>Press ENTER for 3 sec to capture incoming DMX state</i>
INFORMATION	Firmware Version	ver x.x	<i>Fixture firmware version</i>
	Fixture Details	Serial ... xx / RDM ... xx	<i>Show fixture serial, RDM unique ID</i>
	Device Life	Total / User	<i>Shows power cycles, Power Hours, LED Hours</i>
	DMX Link Status	Refresh Rate (Hz) / Frame Length / Mode Length	<i>Details of DMX signal</i>
	Temperatures	xxx...	<i>Unit temperatures</i>
	Fan Speeds	Fan1 ...	
	Error Log	Xxx	
SERVICE	Test All	Running	<i>Press Enter to start test, Menu or Enter to stop</i>
	Test Pan only	Running	
	Test Tilt only	Running	
	Test LED only	Running	
	Test Zoom only	Running	
	Default Settings		<i>See Note 1 below</i>
	Service Advanced	See below for menu	<i>Hold Enter for 6 sec to enter this menu</i>
FACTORY MENU	This menu is for use by authorized service technicians only		

Note 1: Default Setting will return all options to default except DMX address, Control Mode. It does not erase captured scene, preset settings or offset values

*Default settings are written in **BOLD type**.*

**Service Advanced menu**

Hold down Enter for 6 seconds to access this menu.

**Menus****Notes**

Pan Disable	Off/On		
Tilt Disable	Off/On		
Units	°C / °F		
Offsets	Tilt	xxx	
	Zoom	xxx	
Reset Counter	Power Hours		
	Power Cycles		
	LED Hours		
	Max Temperature		
	Temperature Unit		
Save Settings	Preset 1		
	Preset 2		
	Preset 3		
Factory Backup			See Note 2 below

Note 2: Factory backup will reset all options to default, erase captured scene, erase preset settings, erase offset values. User Hour counter and Temperature Unit will not be affected.

## 11. DMX control modes overview

The following DMX control modes are available in the EXO Wash 30.

### DMX Mode 1: Compact

Compact Mode uses 13 DMX channels.

It provides 16-bit control of pan and tilt, dimming and a shutter with strobe and ramp up/down effects. It has a virtual color wheel effect (color presets with rotation effects) and RGBW color mixing.

Compact Mode also provides control of zoom and a control / settings channel that lets you configure the feature and adjust settings remotely via DMX.

#### Mode 1 Compact

1	Pan
2	Pan fine
3	Tilt
4	Tilt fine
5	Dimmer
6	Shutter
7	Virtual color wheel
8	Red
9	Green
10	Blue
11	White
12	Zoom
13	Control / Settings

### DMX Mode 2: Standard

Standard Mode uses 22 DMX channels.

It provides 16-bit control of pan and tilt, 16-bit control of dimming and a shutter with strobe and ramp up/down effects. It has a virtual color wheel effect (color presets with rotation effects), color temperature control and 16-bit RGBW color mixing.

Standard Mode also gives access to a range of Pattern FX with variable speed and crossfading parameters, control of zoom and a control / settings channel that lets you configure the feature and adjust settings remotely via DMX.

#### Mode 2 Standard

1	Pan
2	Pan fine
3	Tilt
4	Tilt fine
5	Dimmer
6	Dimmer fine
7	Shutter
8	Virtual color wheel
9	CTC
10	Red
11	Red fine
12	Green
13	Green fine
14	Blue
15	Blue fine
16	White
17	White fine
18	Pattern
19	Pattern Speed
20	Pattern Fading
21	Zoom
22	Control / Settings

### DMX Mode 3: Extended

Extended Mode uses 37 DMX channels.

It provides 16-bit control of pan and tilt, 16-bit control of dimming and a shutter with strobe and ramp up/down effects. It has a virtual color wheel effect (color presets with rotation effects), color temperature control and 16-bit RGBW color mixing.

Extended Mode also has two layers:

- Layer 1, the background layer, has 16-bit color dimming and a shutter effect that includes a random pixel strobe.
- Layer 2, the top layer, has a range of Pattern FX with 16-bit dimming, shutter effects and color control via a virtual color wheel (color presets) and 16-bit RGBW color mixing. Layer 2 also has variable speed and crossfading parameters

Extended Mode also provides control of zoom and a control / settings channel that lets you configure the feature and adjust settings remotely via DMX.

Mode 3 Extended	
--------------------	--

1	Pan
2	Pan fine
3	Tilt
4	Tilt fine
5	Dimmer
6	Dimmer fine
7	Shutter
8	Virtual color wheel
9	CTC
10	Red
11	Red fine
12	Green
13	Green fine
14	Blue
15	Blue fine
16	White
17	White fine
18	Layer 1 Color dimmer
19	Layer 1 Color dimmer fine
20	Layer 1 Shutter
21	Layer 2 Pattern dimmer
22	Layer 2 Pattern dimmer fine
23	Layer 2 Pattern shutter
24	Layer 2 Pattern color wheel
25	Layer 2 Pattern red
26	Layer 2 Pattern red fine
27	Layer 2 Pattern green
28	Layer 2 Pattern green fine
29	Layer 2 Pattern blue
30	Layer 2 Pattern blue fine
31	Layer 2 Pattern white
32	Layer 2 Pattern white fine
33	Layer 2 Pattern
34	Layer 2 Pattern speed
35	Layer 2 Pattern fading
36	Zoom
37	Control / Settings

### DMX Mode 4: Pix

Pix Mode uses 50 DMX channels.

It provides 16-bit control of pan and tilt, 16-bit control of dimming and a shutter with strobe and ramp up/down effects. It has a virtual color wheel effect (color presets with rotation effects), color temperature control and 16-bit RGBW color mixing.

Pix Mode also gives access to a range of Pattern FX with variable speed and crossfading parameters, control of zoom and a control / settings channel that lets you configure the feature and adjust settings remotely via DMX.

Finally, Pix Mode provides independent RGBW color mixing on each of the fixture's seven pixels.

Mode 4 Pix	
1	Pan
2	Pan fine
3	Tilt
4	Tilt fine
5	Dimmer
6	Dimmer fine
7	Shutter
8	Virtual color wheel
9	CTC
10	Red
11	Red fine
12	Green
13	Green fine
14	Blue
15	Blue fine
16	White
17	White fine
18	Pattern
19	Pattern Speed
20	Pattern Fading
21	Zoom
22	Control / Settings
23	Pixel 1 Red
24	Pixel 1 Green
25	Pixel 1 Blue
26	Pixel 1 White
27	Pixel 2 Red
28	Pixel 2 Green
29	Pixel 2 Blue
30	Pixel 2 White
31	Pixel 3 Red
32	Pixel 3 Green
33	Pixel 3 Blue
34	Pixel 3 White
35	Pixel 4 Red
36	Pixel 4 Green
37	Pixel 4 Blue
38	Pixel 4 White
39	Pixel 5 Red
40	Pixel 5 Green
41	Pixel 5 Blue
42	Pixel 5 White
43	Pixel 6 Red
44	Pixel 6 Green
45	Pixel 6 Blue
46	Pixel 6 White
47	Pixel 7 Red
48	Pixel 7 Green
49	Pixel 7 Blue
50	Pixel 7 White



## 12. DMX control channel layout tables

### DMX Mode 1: Compact

#### 11 DMX Channels

Channel	Command	DMX range		Percent		Default DMX	Fade	
<b>1</b>	<b>Pan</b>	Pan left-right	0	65535	0	100	32767	Fade
<b>2</b>	<b>Pan fine</b>							
<b>3</b>	<b>Tilt</b>	Tilt up-down	0	65535	0	100	32767	Fade
<b>4</b>	<b>Tilt fine</b>							
<b>5</b>	<b>Dimmer</b>	Intensity 0-100%	0	255	0	100	0	Fade
<b>6</b>	<b>Shutter</b>	Shutter closed	0	4	0	1.6	0	Snap
		Single flash when change on dimmer channel	5	9	2.0	3.5		
		Sync ramp up slow-fast	10	39	3.9	15.3		
		Sync ramp down slow-fast	40	69	15.7	27.1		
		Sync ramp up-down slow-fast	70	99	27.5	38.8		
		Sync double flash (slow-fast)	100	129	39.2	50.6		
		Random strobe pixel (slow-fast)	130	159	51.0	62.4		
		Random strobe all (slow-fast)	160	199	62.7	78.0		
		Sync strobe (1 Hz-10 Hz)	200	250	78.4	98.0		
	Shutter open	251	255	98.4	100			
<b>7</b>	<b>Color wheel effect</b>	Off (RGBW)	0	7	0	2.7	0	Snap
		Color 01 - Red	8	15	3.1	5.9		Snap
		Color 02 - Amber	16	23	6.3	9.0		Snap
		Color 03 - Warm Yellow	24	31	9.4	12.2		Snap
		Color 04 - Yellow	32	39	12.5	15.3		Snap
		Color 05 - Green	40	47	15.7	18.4		Snap
		Color 06 - Turquoise	48	55	18.8	21.6		Snap
		Color 07 - Cyan	56	63	22.0	24.7		Snap
		Color 08 - Blue	64	71	25.1	27.8		Snap
		Color 09 - Lavender	72	79	28.2	31.0		Snap
		Color 10 - Mauve	80	87	31.4	34.1		Snap
		Color 11 - Magenta	88	95	34.5	37.3		Snap
		Color 12 - Pink	96	103	37.6	40.4		Snap
		Color 13 - White 3200K	104	111	40.8	43.5		Snap
		Color 14 - White 5600K	112	119	43.9	46.7		Snap
		Color 15 - White 7200K	120	127	47.1	49.8		Snap
		Stop	128	128	50.2	50.2		Snap
Rainbow colors crossfade slow > fast	129	223	50.6	87.5	Fade			
Random colors crossfade slow > fast	224	255	87.8	100	Fade			
<b>8</b>	<b>Red</b>	Red intensity 0-100%	0	255	0	100	0	Fade
<b>9</b>	<b>Green</b>	Green intensity 0-100%	0	255	0	100	0	Fade
<b>10</b>	<b>Blue</b>	Blue intensity 0-100%	0	255	0	100	0	Fade
<b>11</b>	<b>White</b>	White intensity 0-100%	0	255	0	100	0	Fade
<b>12</b>	<b>Zoom</b>	Wide-narrow	0	255	0	100	0	Fade

13	Control / Settings	No function	0	9	0.0	3.5	0	Snap
		<b>Dimmer curve: Extra-soft (3s hold)</b>	10	15	3.9	5.9		
		Dimmer curve: Linear (3s hold)	16	21	6.3	8.2		
		<b>Display mode: Auto (3s hold)</b>	22	27	8.6	10.6		
		Display mode: On (3s hold)	28	33	11.0	12.9		
		Display mode: Off (3s hold)	34	39	13.3	15.3		
		<b>Display orientation: Normal (3s hold)</b>	40	45	15.7	17.6		
		Display orientation: Inverted (3s hold)	46	51	18.0	20.0		
		No DMX: Blackout (3s hold)	52	57	20.4	22.4		
		<b>No DMX: Hold (3s hold)</b>	58	63	22.7	24.7		
		No DMX: Stand-alone (3s hold)	64	69	25.1	27.1		
		<b>Fan mode: Regulated (3s hold)</b>	70	75	27.5	29.4		
		Fan mode: High (3s hold)	76	81	29.8	31.8		
		Fan mode: Medium (3s hold)	82	87	32.2	34.1		
		Fan mode: Low (3s hold)	88	93	34.5	36.5		
		Position feedback: Off (3s hold)	94	99	36.9	38.8		
		<b>Position feedback: On (3s hold)</b>	100	105	39.2	41.2		
		No function	106	117	41.6	45.9		
		<b>Tilt inversion: Off (3s hold)</b>	118	123	46.3	48.2		
		Tilt inversion: On (3s hold)	124	129	48.6	50.6		
		<b>Pan inversion: Off (3s hold)</b>	130	135	51.0	52.9		
		Pan inversion: On (3s hold)	136	141	53.3	55.3		
		<b>Zoom inversion: Off (3s hold)</b>	142	147	55.7	57.6		
		Zoom inversion: On (3s hold)	148	153	58.0	60.0		
		<b>Defog: Off</b>	154	159	60.4	62.4		
		Defog: On	160	165	62.7	64.7		
		Defog: Quick	166	171	65.1	67.1		
		Load Settings Preset1	172	177	67.5	69.4		
		Load Settings Preset2	178	183	69.8	71.8		
		Load Settings Preset3	184	189	72.2	74.1		
		PWM 600 Hz (5s hold)	190	195	74.5	76.5		
		PWM: 2200 Hz (5s hold)	196	201	76.9	78.8		
		<b>PWM: 3000 Hz (5s hold)</b>	202	207	79.2	81.2		
		PWM: 4800 Hz (5s hold)	208	213	81.6	83.5		
		PWM: 9600 Hz (5s hold)	214	219	83.9	85.9		
		PWM: 25 kHz (5s hold)	220	225	86.3	88.2		
		No function	226	231	88.6	90.6		
		Return to default settings	232	237	91.0	92.9		
		Reset Pan/Tilt (3s hold)	238	243	93.3	95.3		
		Reset Head (3s hold)	244	249	95.7	97.6		
Reset All (3s hold)	250	255	98.0	100				

**DMX Mode 2: Standard**

**22 DMX Channels**

Channel	Command	DMX range		Percent		Default DMX	Fade	
1	Pan	Pan left-right	0	65535	0	100	32767	Fade
2	Pan fine							
3	Tilt	Tilt up-down	0	65535	0	100	32767	Fade
4	Tilt fine							
5	Dimmer	Intensity 0-100%	0	65535	0	100	32767	Fade
6	Dimmer fine							
7	Shutter	Shutter closed	0	4	0	1.6	0	Snap
		Single flash when change on dimmer channel	5	9	2.0	3.5		
		Sync ramp up slow-fast	10	39	3.9	15.3		
		Sync ramp down slow-fast	40	69	15.7	27.1		
		Sync ramp up-down slow-fast	70	99	27.5	38.8		
		Sync double flash (slow-fast)	100	129	39.2	50.6		
		Random strobe pixel (slow-fast)	130	159	51.0	62.4		
		Random strobe all (slow-fast)	160	199	62.7	78.0		
		Sync strobe (1 Hz-10 Hz)	200	250	78.4	98.0		
Shutter open	251	255	98.4	100				
8	Color wheel effect	Off (RGBW)	0	7	0	2.7	0	Snap
		Color 01 - Red	8	15	3.1	5.9		Snap
		Color 02 - Amber	16	23	6.3	9.0		Snap
		Color 03 - Warm Yellow	24	31	9.4	12.2		Snap
		Color 04 - Yellow	32	39	12.5	15.3		Snap
		Color 05 - Green	40	47	15.7	18.4		Snap
		Color 06 - Turquoise	48	55	18.8	21.6		Snap
		Color 07 - Cyan	56	63	22.0	24.7		Snap
		Color 08 - Blue	64	71	25.1	27.8		Snap
		Color 09 - Lavender	72	79	28.2	31.0		Snap
		Color 10 - Mauve	80	87	31.4	34.1		Snap
		Color 11 - Magenta	88	95	34.5	37.3		Snap
		Color 12 - Pink	96	103	37.6	40.4		Snap
		Color 13 - White 3200K	104	111	40.8	43.5		Snap
		Color 14 - White 5600K	112	119	43.9	46.7		Snap
		Color 15 - White 7200K	120	127	47.1	49.8		Snap
		Stop	128	128	50.2	50.2		Snap
		Rainbow colors crossfade slow > fast	129	223	50.6	87.5		Fade
Random colors crossfade slow > fast	224	255	87.8	100	Fade			
9	Color Temperature (Kelvin)	RAW	0	15	0	5.9		Snap
		10000	16	18	6.3	7.1		
		9900	19	21	7.5	8.2		
		9800	22	24	8.6	9.4		
		9700	25	27	9.8	10.6		
		9600	28	30	11.0	11.8		
		9500	31	33	12.2	12.9		
		9400	34	36	13.3	14.1		
		9300	37	39	14.5	15.3		
		9200	40	42	15.7	16.5		
		9100	43	45	16.9	17.6		
		9000	46	48	18.0	18.8		
		8900	49	51	19.2	20.0		
		8800	52	54	20.4	21.2		
		8700	55	57	21.6	22.4		

8600	58	60	22.7	23.5
8500	61	63	23.9	24.7
8400	64	66	25.1	25.9
8300	67	69	26.3	27.1
8200	70	72	27.5	28.2
8100	73	75	28.6	29.4
8000	76	78	29.8	30.6
7900	79	81	31.0	31.8
7800	82	84	32.2	32.9
7700	85	87	33.3	34.1
7600	88	90	34.5	35.3
7500	91	93	35.7	36.5
7400	94	96	36.9	37.6
7300	97	99	38.0	38.8
7200	100	102	39.2	40.0
7100	103	105	40.4	41.2
7000	106	108	41.6	42.4
6900	109	111	42.7	43.5
6800	112	114	43.9	44.7
6700	115	117	45.1	45.9
6600	118	120	46.3	47.1
6500	121	123	47.5	48.2
6400	124	126	48.6	49.4
6300	127	129	49.8	50.6
6200	130	132	51.0	51.8
6100	133	135	52.2	52.9
6000	136	138	53.3	54.1
5900	139	141	54.5	55.3
5800	142	144	55.7	56.5
5700	145	147	56.9	57.6
5600	148	150	58.0	58.8
5500	151	153	59.2	60.0
5400	154	156	60.4	61.2
5300	157	159	61.6	62.4
5200	160	162	62.7	63.5
5100	163	165	63.9	64.7
5000	166	168	65.1	65.9
4900	169	171	66.3	67.1
4800	172	174	67.5	68.2
4700	175	177	68.6	69.4
4600	178	180	69.8	70.6
4500	181	183	71.0	71.8
4400	184	186	72.2	72.9
4300	187	189	73.3	74.1
4200	190	192	74.5	75.3
4100	193	195	75.7	76.5
4000	196	198	76.9	77.6
3900	199	201	78.0	78.8
3800	202	204	79.2	80.0
3700	205	207	80.4	81.2
3600	208	210	81.6	82.4
3500	211	213	82.7	83.5
3400	214	216	83.9	84.7
3300	217	219	85.1	85.9
3200	220	222	86.3	87.1
3100	223	225	87.5	88.2
3000	226	228	88.6	89.4
2900	229	231	89.8	90.6

		2800	232	234	91.0	91.8		
		2700	235	237	92.2	92.9		
		2600	238	240	93.3	94.1		
		2500	241	255	94.5	100		
10	<b>Red</b>	Red intensity 0–100%	0	65535	0	100	32767	Fade
11	<b>Red fine</b>							
12	<b>Green</b>	Green intensity 0–100%	0	65535	0	100	32767	Fade
13	<b>Green fine</b>							
14	<b>Blue</b>	Blue intensity 0–100%	0	65535	0	100	32767	Fade
15	<b>Blue fine</b>							
16	<b>White</b>	White intensity 0–100%	0	65535	0	100	32767	Fade
17	<b>White fine</b>							
18	<b>Pattern</b>	Static pattern	0	51	0	20.0	0	Snap
		Chase animation	52	131	20.4	51.4		
		Fade animation	132	211	51.8	82.7		
		Random	212	255	83.1	100		
19	<b>Pattern speed</b>	Slow–fast	0	255	0	100	0	Fade
20	<b>Pattern fade</b>	Slow crossfade–snap	0	255	0	100	0	Fade
21	<b>Zoom</b>	Wide–narrow	0	255	0	100	0	Fade
22	<b>Control / Settings</b>	No function	0	9	0.0	3.5	0	Snap
		<b>Dimmer curve: Extra-soft (3s hold)</b>	10	15	3.9	5.9		
		Dimmer curve: Linear (3s hold)	16	21	6.3	8.2		
		<b>Display mode: Auto (3s hold)</b>	22	27	8.6	10.6		
		Display mode: On (3s hold)	28	33	11.0	12.9		
		Display mode: Off (3s hold)	34	39	13.3	15.3		
		<b>Display orientation: Normal (3s hold)</b>	40	45	15.7	17.6		
		Display orientation: Inverted (3s hold)	46	51	18.0	20.0		
		No DMX: Blackout (3s hold)	52	57	20.4	22.4		
		<b>No DMX: Hold (3s hold)</b>	58	63	22.7	24.7		
		No DMX: Stand-alone (3s hold)	64	69	25.1	27.1		
		<b>Fan mode: Regulated (3s hold)</b>	70	75	27.5	29.4		
		Fan mode: High (3s hold)	76	81	29.8	31.8		
		Fan mode: Medium (3s hold)	82	87	32.2	34.1		
		Fan mode: Low (3s hold)	88	93	34.5	36.5		
		Position feedback: Off (3s hold)	94	99	36.9	38.8		
		<b>Position feedback: On (3s hold)</b>	100	105	39.2	41.2		
		No function	106	117	41.6	45.9		
		<b>Tilt inversion: Off (3s hold)</b>	118	123	46.3	48.2		
		Tilt inversion: On (3s hold)	124	129	48.6	50.6		
		<b>Pan inversion: Off (3s hold)</b>	130	135	51.0	52.9		
		Pan inversion: On (3s hold)	136	141	53.3	55.3		
		<b>Zoom inversion: Off (3s hold)</b>	142	147	55.7	57.6		
		Zoom inversion: On (3s hold)	148	153	58.0	60.0		
		<b>Defog: Off</b>	154	159	60.4	62.4		
		Defog: On	160	165	62.7	64.7		
		Defog: Quick	166	171	65.1	67.1		
		Load Settings Preset1	172	177	67.5	69.4		
		Load Settings Preset2	178	183	69.8	71.8		
		Load Settings Preset3	184	189	72.2	74.1		
		PWM: 600 Hz (5s hold)	190	195	74.5	76.5		
		PWM: 2200 Hz (5s hold)	196	201	76.9	78.8		
<b>PWM: 3000 Hz (5s hold)</b>	202	207	79.2	81.2				
PWM: 4800 Hz (5s hold)	208	213	81.6	83.5				
PWM: 9600 Hz (5s hold)	214	219	83.9	85.9				
PWM: 25 kHz (5s hold)	220	225	86.3	88.2				

	No function	226	231	88.6	90.6		
	Return to default settings	232	237	91.0	92.9		
	Reset Pan/Tilt (3s hold)	238	243	93.3	95.3		
	Reset Head (3s hold)	244	249	95.7	97.6		
	Reset All (3s hold)	250	255	98.0	100		

**DMX Mode 3: Extended**

**37 DMX Channels**

Channel		Command	DMX range		Percent		Default DMX	Fade
1	<b>Pan</b>	Pan left-right	0	65535	0	100	32767	Fade
2	<b>Pan fine</b>							
3	<b>Tilt</b>	Tilt up-down	0	65535	0	100	32767	Fade
4	<b>Tilt fine</b>							
5	<b>Dimmer</b>	Intensity 0-100%	0	65535	0	100	32767	Fade
6	<b>Dimmer fine</b>							
7	<b>Shutter</b>	Shutter closed	0	4	0	1.6	0	Snap
		Single flash when change on dimmer channel	5	9	2.0	3.5		
		Sync ramp up slow-fast	10	39	3.9	15.3		
		Sync ramp down slow-fast	40	69	15.7	27.1		
		Sync ramp up-down slow-fast	70	99	27.5	38.8		
		Sync double flash (slow-fast)	100	129	39.2	50.6		
		Random strobe pixel (slow-fast)	130	159	51.0	62.4		
		Random strobe all (slow-fast)	160	199	62.7	78.0		
		Sync strobe (1 Hz-10 Hz)	200	250	78.4	98.0		
	Shutter open	251	255	98.4	100			
8	<b>Color wheel effect</b>	Off (RGBW)	0	7	0	2.7	0	Snap
		Color 01 - Red	8	15	3.1	5.9		Snap
		Color 02 - Amber	16	23	6.3	9.0		Snap
		Color 03 - Warm Yellow	24	31	9.4	12.2		Snap
		Color 04 - Yellow	32	39	12.5	15.3		Snap
		Color 05 - Green	40	47	15.7	18.4		Snap
		Color 06 - Turquoise	48	55	18.8	21.6		Snap
		Color 07 - Cyan	56	63	22.0	24.7		Snap
		Color 08 - Blue	64	71	25.1	27.8		Snap
		Color 09 - Lavender	72	79	28.2	31.0		Snap
		Color 10 - Mauve	80	87	31.4	34.1		Snap
		Color 11 - Magenta	88	95	34.5	37.3		Snap
		Color 12 - Pink	96	103	37.6	40.4		Snap
		Color 13 - White 3200K	104	111	40.8	43.5		Snap
		Color 14 - White 5600K	112	119	43.9	46.7		Snap
		Color 15 - White 7200K	120	127	47.1	49.8		Snap
			Stop	128	128	50.2		50.2
	Rainbow colors crossfade slow > fast	129	223	50.6	87.5	Fade		
	Random colors crossfade slow > fast	224	255	87.8	100	Fade		
9	<b>Color Temperature (Kelvin)</b>	RAW	0	15	0	5.9		Snap
		10000	16	18	6.3	7.1		
		9900	19	21	7.5	8.2		
		9800	22	24	8.6	9.4		
		9700	25	27	9.8	10.6		
		9600	28	30	11.0	11.8		
		9500	31	33	12.2	12.9		
		9400	34	36	13.3	14.1		
		9300	37	39	14.5	15.3		
		9200	40	42	15.7	16.5		
		9100	43	45	16.9	17.6		
		9000	46	48	18.0	18.8		
		8900	49	51	19.2	20.0		
		8800	52	54	20.4	21.2		
		8700	55	57	21.6	22.4		
		8600	58	60	22.7	23.5		
		8500	61	63	23.9	24.7		
8400	64	66	25.1	25.9				

		8300	67	69	26.3	27.1		
		8200	70	72	27.5	28.2		
		8100	73	75	28.6	29.4		
		8000	76	78	29.8	30.6		
		7900	79	81	31.0	31.8		
		7800	82	84	32.2	32.9		
		7700	85	87	33.3	34.1		
		7600	88	90	34.5	35.3		
		7500	91	93	35.7	36.5		
		7400	94	96	36.9	37.6		
		7300	97	99	38.0	38.8		
		7200	100	102	39.2	40.0		
		7100	103	105	40.4	41.2		
		7000	106	108	41.6	42.4		
		6900	109	111	42.7	43.5		
		6800	112	114	43.9	44.7		
		6700	115	117	45.1	45.9		
		6600	118	120	46.3	47.1		
		6500	121	123	47.5	48.2		
		6400	124	126	48.6	49.4		
		6300	127	129	49.8	50.6		
		6200	130	132	51.0	51.8		
		6100	133	135	52.2	52.9		
		6000	136	138	53.3	54.1		
		5900	139	141	54.5	55.3		
		5800	142	144	55.7	56.5		
		5700	145	147	56.9	57.6		
		5600	148	150	58.0	58.8		
		5500	151	153	59.2	60.0		
		5400	154	156	60.4	61.2		
		5300	157	159	61.6	62.4		
		5200	160	162	62.7	63.5		
		5100	163	165	63.9	64.7		
		5000	166	168	65.1	65.9		
		4900	169	171	66.3	67.1		
		4800	172	174	67.5	68.2		
		4700	175	177	68.6	69.4		
		4600	178	180	69.8	70.6		
		4500	181	183	71.0	71.8		
		4400	184	186	72.2	72.9		
		4300	187	189	73.3	74.1		
		4200	190	192	74.5	75.3		
		4100	193	195	75.7	76.5		
		4000	196	198	76.9	77.6		
		3900	199	201	78.0	78.8		
		3800	202	204	79.2	80.0		
		3700	205	207	80.4	81.2		
		3600	208	210	81.6	82.4		
		3500	211	213	82.7	83.5		
		3400	214	216	83.9	84.7		
		3300	217	219	85.1	85.9		
		3200	220	222	86.3	87.1		
		3100	223	225	87.5	88.2		
		3000	226	228	88.6	89.4		
		2900	229	231	89.8	90.6		
		2800	232	234	91.0	91.8		
		2700	235	237	92.2	92.9		
		2600	238	240	93.3	94.1		
		2500	241	255	94.5	100		
<b>10</b>	<b>Red</b>							
<b>11</b>	<b>Red fine</b>	Red intensity 0-100%	0	65535	0	100	32767	Fade



12	<b>Green</b>	Green intensity 0–100%	0	65535	0	100	32767	Fade
13	<b>Green fine</b>							
14	<b>Blue</b>	Blue intensity 0–100%	0	65535	0	100	32767	Fade
15	<b>Blue fine</b>							
16	<b>White</b>	White intensity 0–100%	0	65535	0	100	32767	Fade
17	<b>White fine</b>							
18	<b>Layer 1 Dimmer</b>	Layer 1 (background) intensity 0–100%	0	65535	0	100	32767	Fade
19	<b>Layer 1 Dimmer fine</b>							
20	<b>Layer 1 Shutter</b>	Layer 1 (background) shutter closed	0	4	0	1.6	0	Snap
		Single flash when change on dimmer channel	5	9	2.0	3.5		
		Sync ramp up slow–fast	10	39	3.9	15.3		
		Sync ramp down slow–fast	40	69	15.7	27.1		
		Sync ramp up–down slow–fast	70	99	27.5	38.8		
		Sync double flash (slow–fast)	100	129	39.2	50.6		
		Random strobe pixel (slow–fast)	130	159	51.0	62.4		
		Random strobe all (slow–fast)	160	199	62.7	78.0		
		Shutter open	251	255	98.4	100		
21	<b>Layer 2 Dimmer</b>	Layer 2 (top layer) intensity 0–100%	0	65535	0	100	32767	Fade
22	<b>Layer 2 Dimmer fine</b>							
23	<b>Layer 2 Pattern Shutter</b>	Shutter closed	0	4	0	1.6	0	Snap
		Single flash when change on dimmer channel	5	9	2.0	3.5		
		Sync ramp up slow–fast	10	39	3.9	15.3		
		Sync ramp down slow–fast	40	69	15.7	27.1		
		Sync ramp up–down slow–fast	70	99	27.5	38.8		
		Sync double flash (slow–fast)	100	129	39.2	50.6		
		Random strobe pixel (slow–fast)	130	159	51.0	62.4		
		Random strobe all (slow–fast)	160	199	62.7	78.0		
		Shutter open	251	255	98.4	100		
24	<b>Layer 2 Pattern color wheel effect</b>	Layer 2 (top layer) pattern off (RGBW)	0	7	0	2.7	0	Snap
		Color 01 - Red	8	15	3.1	5.9		Snap
		Color 02 - Amber	16	23	6.3	9.0		Snap
		Color 03 - Warm Yellow	24	31	9.4	12.2		Snap
		Color 04 - Yellow	32	39	12.5	15.3		Snap
		Color 05 - Green	40	47	15.7	18.4		Snap
		Color 06 - Turquoise	48	55	18.8	21.6		Snap
		Color 07 - Cyan	56	63	22.0	24.7		Snap
		Color 08 - Blue	64	71	25.1	27.8		Snap
		Color 09 - Lavender	72	79	28.2	31.0		Snap
		Color 10 - Mauve	80	87	31.4	34.1		Snap
		Color 11 - Magenta	88	95	34.5	37.3		Snap
		Color 12 - Pink	96	103	37.6	40.4		Snap
		Color 13 - White 3200K	104	111	40.8	43.5		Snap
		Color 14 - White 5600K	112	119	43.9	46.7		Snap
		Color 15 - White 7200K	120	127	47.1	49.8		Snap
		Stop	128	128	50.2	50.2		Snap
		Rainbow colors crossfade slow > fast	129	223	50.6	87.5		Fade
Random colors crossfade slow > fast	224	255	87.8	100	Fade			
25	<b>Layer 2 Pattern Red</b>	Layer 2 (top layer) pattern red intensity 0–100%	0	65535	0	100	32767	Fade
26	<b>Layer 2 Pattern Red fine</b>							
27	<b>Layer 2 Pattern Green</b>	Layer 2 (top layer) pattern green intensity 0–100%	0	65535	0	100	32767	Fade

28	Layer 2 Pattern Green fine							
29	Layer 2 Pattern Blue	Layer 2 (top layer) pattern blue intensity 0–100%	0	65535	0	100	32767	Fade
30	Layer 2 Pattern Blue fine							
31	Layer 2 Pattern White	Layer 2 (top layer) pattern white intensity 0–100%	0	65535	0	100	32767	Fade
32	Layer 2 Pattern White fine							
33	Layer 2 Pattern	Layer 2 (top layer) static pattern	0	51	0	20.0	0	Snap
		Chase animation	52	131	20.4	51.4		
		Fade animation	132	211	51.8	82.7		
		Random	212	255	83.1	100		
34	Layer 2 Pattern speed	Slow–fast	0	255	0	100	0	Fade
35	Layer 2 Pattern fade	Slow crossfade–snap	0	255	0	100	0	Fade
36	Zoom	Wide–narrow	0	255	0	100	0	Fade
37	Control / Settings	No function	0	9	0.0	3.5	0	Snap
		<b>Dimmer curve: Extra-soft (3s hold)</b>	10	15	3.9	5.9		
		Dimmer curve: Linear (3s hold)	16	21	6.3	8.2		
		<b>Display mode: Auto (3s hold)</b>	22	27	8.6	10.6		
		Display mode: On (3s hold)	28	33	11.0	12.9		
		Display mode: Off (3s hold)	34	39	13.3	15.3		
		<b>Display orientation: Normal (3s hold)</b>	40	45	15.7	17.6		
		Display orientation: Inverted (3s hold)	46	51	18.0	20.0		
		No DMX: Blackout (3s hold)	52	57	20.4	22.4		
		<b>No DMX: Hold (3s hold)</b>	58	63	22.7	24.7		
		No DMX: Stand-alone (3s hold)	64	69	25.1	27.1		
		<b>Fan mode: Regulated (3s hold)</b>	70	75	27.5	29.4		
		Fan mode: High (3s hold)	76	81	29.8	31.8		
		Fan mode: Medium (3s hold)	82	87	32.2	34.1		
		Fan mode: Low (3s hold)	88	93	34.5	36.5		
		Position feedback: Off (3s hold)	94	99	36.9	38.8		
		<b>Position feedback: On (3s hold)</b>	100	105	39.2	41.2		
		No function	106	117	41.6	45.9		
		<b>Tilt inversion: Off (3s hold)</b>	118	123	46.3	48.2		
		Tilt inversion: On (3s hold)	124	129	48.6	50.6		
		<b>Pan inversion: Off (3s hold)</b>	130	135	51.0	52.9		
		Pan inversion: On (3s hold)	136	141	53.3	55.3		
		<b>Zoom inversion: Off (3s hold)</b>	142	147	55.7	57.6		
		Zoom inversion: On (3s hold)	148	153	58.0	60.0		
		<b>Defog: Off</b>	154	159	60.4	62.4		
		Defog: On	160	165	62.7	64.7		
		Defog: Quick	166	171	65.1	67.1		
		Load Settings Preset1	172	177	67.5	69.4		
		Load Settings Preset2	178	183	69.8	71.8		
		Load Settings Preset3	184	189	72.2	74.1		
		PWM: 600 Hz (5s hold)	190	195	74.5	76.5		
		PWM: 2200 Hz (5s hold)	196	201	76.9	78.8		
<b>PWM: 3000 Hz (5s hold)</b>	202	207	79.2	81.2				
PWM: 4800 Hz (5s hold)	208	213	81.6	83.5				
PWM: 9600 Hz (5s hold)	214	219	83.9	85.9				
PWM: 25 kHz (5s hold)	220	225	86.3	88.2				
No function	226	231	88.6	90.6				
Return to default settings	232	237	91.0	92.9				
Reset Pan/Tilt (3s hold)	238	243	93.3	95.3				

	Reset Head (3s hold)	244	249	95.7	97.6		
	Reset All (3s hold)	250	255	98.0	100		

DMX Mode 4: Pix

## 50 DMX Channels

	Channel	Command	DMX range		Percent		Default DMX	Fade
1	<b>Pan</b>	Pan left-right	0	65535	0	100	32767	Fade
2	<b>Pan fine</b>							
3	<b>Tilt</b>	Tilt up-down	0	65535	0	100	32767	Fade
4	<b>Tilt fine</b>							
5	<b>Dimmer</b>	Intensity 0-100%	0	65535	0	100	32767	Fade
6	<b>Dimmer fine</b>							
7	<b>Shutter</b>	Shutter closed	0	4	0	1.6	0	Snap
		Single flash when change on dimmer channel	5	9	2.0	3.5		
		Sync ramp up slow-fast	10	39	3.9	15.3		
		Sync ramp down slow-fast	40	69	15.7	27.1		
		Sync ramp up-down slow-fast	70	99	27.5	38.8		
		Sync double flash (slow-fast)	100	129	39.2	50.6		
		Random strobe pixel (slow-fast)	130	159	51.0	62.4		
		Random strobe all (slow-fast)	160	199	62.7	78.0		
		Sync strobe (1 Hz-10 Hz)	200	250	78.4	98.0		
Shutter open	251	255	98.4	100				
8	<b>Color wheel effect</b>	Off (RGBW)	0	7	0	2.7	0	Snap
		Color 01 - Red	8	15	3.1	5.9		Snap
		Color 02 - Amber	16	23	6.3	9.0		Snap
		Color 03 - Warm Yellow	24	31	9.4	12.2		Snap
		Color 04 - Yellow	32	39	12.5	15.3		Snap
		Color 05 - Green	40	47	15.7	18.4		Snap
		Color 06 - Turquoise	48	55	18.8	21.6		Snap
		Color 07 - Cyan	56	63	22.0	24.7		Snap
		Color 08 - Blue	64	71	25.1	27.8		Snap
		Color 09 - Lavender	72	79	28.2	31.0		Snap
		Color 10 - Mauve	80	87	31.4	34.1		Snap
		Color 11 - Magenta	88	95	34.5	37.3		Snap
		Color 12 - Pink	96	103	37.6	40.4		Snap
		Color 13 - White 3200K	104	111	40.8	43.5		Snap
		Color 14 - White 5600K	112	119	43.9	46.7		Snap
		Color 15 - White 7200K	120	127	47.1	49.8		Snap
		Stop	128	128	50.2	50.2		Snap
		Rainbow colors crossfade slow > fast	129	223	50.6	87.5		Fade
Random colors crossfade slow > fast	224	255	87.8	100	Fade			
9	<b>Color Temperature (Kelvin)</b>	RAW	0	15	0	5.9	Snap	
		10000	16	18	6.3	7.1		
		9900	19	21	7.5	8.2		
		9800	22	24	8.6	9.4		
		9700	25	27	9.8	10.6		
		9600	28	30	11.0	11.8		
		9500	31	33	12.2	12.9		
		9400	34	36	13.3	14.1		
		9300	37	39	14.5	15.3		
		9200	40	42	15.7	16.5		
		9100	43	45	16.9	17.6		
		9000	46	48	18.0	18.8		
		8900	49	51	19.2	20.0		
		8800	52	54	20.4	21.2		
		8700	55	57	21.6	22.4		
		8600	58	60	22.7	23.5		
		8500	61	63	23.9	24.7		
8400	64	66	25.1	25.9				

		8300	67	69	26.3	27.1		
		8200	70	72	27.5	28.2		
		8100	73	75	28.6	29.4		
		8000	76	78	29.8	30.6		
		7900	79	81	31.0	31.8		
		7800	82	84	32.2	32.9		
		7700	85	87	33.3	34.1		
		7600	88	90	34.5	35.3		
		7500	91	93	35.7	36.5		
		7400	94	96	36.9	37.6		
		7300	97	99	38.0	38.8		
		7200	100	102	39.2	40.0		
		7100	103	105	40.4	41.2		
		7000	106	108	41.6	42.4		
		6900	109	111	42.7	43.5		
		6800	112	114	43.9	44.7		
		6700	115	117	45.1	45.9		
		6600	118	120	46.3	47.1		
		6500	121	123	47.5	48.2		
		6400	124	126	48.6	49.4		
		6300	127	129	49.8	50.6		
		6200	130	132	51.0	51.8		
		6100	133	135	52.2	52.9		
		6000	136	138	53.3	54.1		
		5900	139	141	54.5	55.3		
		5800	142	144	55.7	56.5		
		5700	145	147	56.9	57.6		
		5600	148	150	58.0	58.8		
		5500	151	153	59.2	60.0		
		5400	154	156	60.4	61.2		
		5300	157	159	61.6	62.4		
		5200	160	162	62.7	63.5		
		5100	163	165	63.9	64.7		
		5000	166	168	65.1	65.9		
		4900	169	171	66.3	67.1		
		4800	172	174	67.5	68.2		
		4700	175	177	68.6	69.4		
		4600	178	180	69.8	70.6		
		4500	181	183	71.0	71.8		
		4400	184	186	72.2	72.9		
		4300	187	189	73.3	74.1		
		4200	190	192	74.5	75.3		
		4100	193	195	75.7	76.5		
		4000	196	198	76.9	77.6		
		3900	199	201	78.0	78.8		
		3800	202	204	79.2	80.0		
		3700	205	207	80.4	81.2		
		3600	208	210	81.6	82.4		
		3500	211	213	82.7	83.5		
		3400	214	216	83.9	84.7		
		3300	217	219	85.1	85.9		
		3200	220	222	86.3	87.1		
		3100	223	225	87.5	88.2		
		3000	226	228	88.6	89.4		
		2900	229	231	89.8	90.6		
		2800	232	234	91.0	91.8		
		2700	235	237	92.2	92.9		
		2600	238	240	93.3	94.1		
		2500	241	255	94.5	100		
<b>10</b>	<b>Red</b>							
<b>11</b>	<b>Red fine</b>	Red intensity 0-100%	0	65535	0	100	32767	Fade

12	<b>Green</b>	Green intensity 0–100%	0	65535	0	100	32767	Fade
13	<b>Green fine</b>							
14	<b>Blue</b>	Blue intensity 0–100%	0	65535	0	100	32767	Fade
15	<b>Blue fine</b>							
16	<b>White</b>	White intensity 0–100%	0	65535	0	100	32767	Fade
17	<b>White fine</b>							
18	<b>Pattern</b>	Static pattern	0	51	0	20.0	0	Snap
		Chase animation	52	131	20.4	51.4		
		Fade animation	132	211	51.8	82.7		
		Random	212	255	83.1	100		
19	<b>Pattern speed</b>	Slow–fast	0	255	0	100	0	Fade
20	<b>Pattern fade</b>	Slow crossfade–snap	0	255	0	100	0	Fade
21	<b>Zoom</b>	Wide–narrow	0	255	0	100	0	Fade
22	<b>Control / Settings</b>	No function	0	9	0.0	3.5	0	Snap
		<b>Dimmer curve: Extra-soft (3s hold)</b>	10	15	3.9	5.9		
		Dimmer curve: Linear (3s hold)	16	21	6.3	8.2		
		<b>Display mode: Auto (3s hold)</b>	22	27	8.6	10.6		
		Display mode: On (3s hold)	28	33	11.0	12.9		
		Display mode: Off (3s hold)	34	39	13.3	15.3		
		<b>Display orientation: Normal (3s hold)</b>	40	45	15.7	17.6		
		Display orientation: Inverted (3s hold)	46	51	18.0	20.0		
		No DMX: Blackout (3s hold)	52	57	20.4	22.4		
		<b>No DMX: Hold (3s hold)</b>	58	63	22.7	24.7		
		No DMX: Stand-alone (3s hold)	64	69	25.1	27.1		
		<b>Fan mode: Regulated (3s hold)</b>	70	75	27.5	29.4		
		Fan mode: High (3s hold)	76	81	29.8	31.8		
		Fan mode: Medium (3s hold)	82	87	32.2	34.1		
		Fan mode: Low (3s hold)	88	93	34.5	36.5		
		Position feedback: Off (3s hold)	94	99	36.9	38.8		
		<b>Position feedback: On (3s hold)</b>	100	105	39.2	41.2		
		No function	106	117	41.6	45.9		
		<b>Tilt inversion: Off (3s hold)</b>	118	123	46.3	48.2		
		Tilt inversion: On (3s hold)	124	129	48.6	50.6		
		<b>Pan inversion: Off (3s hold)</b>	130	135	51.0	52.9		
		Pan inversion: On (3s hold)	136	141	53.3	55.3		
		<b>Zoom inversion: Off (3s hold)</b>	142	147	55.7	57.6		
		Zoom inversion: On (3s hold)	148	153	58.0	60.0		
		<b>Defog: Off</b>	154	159	60.4	62.4		
		Defog: On	160	165	62.7	64.7		
		Defog: Quick	166	171	65.1	67.1		
		Load Settings Preset1	172	177	67.5	69.4		
		Load Settings Preset2	178	183	69.8	71.8		
		Load Settings Preset3	184	189	72.2	74.1		
		PWM: 600 Hz (5s hold)	190	195	74.5	76.5		
		PWM: 2200 Hz (5s hold)	196	201	76.9	78.8		
<b>PWM: 3000 Hz (5s hold)</b>	202	207	79.2	81.2				
PWM: 4800 Hz (5s hold)	208	213	81.6	83.5				
PWM: 9600 Hz (5s hold)	214	219	83.9	85.9				
PWM: 25 kHz (5s hold)	220	225	86.3	88.2				
No function	226	231	88.6	90.6				
Return to default settings	232	237	91.0	92.9				
Reset Pan/Tilt (3s hold)	238	243	93.3	95.3				
Reset Head (3s hold)	244	249	95.7	97.6				
Reset All (3s hold)	250	255	98.0	100				
23	<b>Pixel 1 Red</b>	Intensity 0-100%	0	255	0	100	0	Fade
24	<b>Pixel 1 Green</b>	Intensity 0-100%	0	255	0	100	0	Fade
25	<b>Pixel 1 Blue</b>	Intensity 0-100%	0	255	0	100	0	Fade

26	Pixel 1 White	Intensity 0-100%	0	255	0	100	0	Fade
27	Pixel 2 Red	Intensity 0-100%	0	255	0	100	0	Fade
28	Pixel 2 Green	Intensity 0-100%	0	255	0	100	0	Fade
29	Pixel 2 Blue	Intensity 0-100%	0	255	0	100	0	Fade
30	Pixel 2 White	Intensity 0-100%	0	255	0	100	0	Fade
31	Pixel 3 Red	Intensity 0-100%	0	255	0	100	0	Fade
32	Pixel 3 Green	Intensity 0-100%	0	255	0	100	0	Fade
33	Pixel 3 Blue	Intensity 0-100%	0	255	0	100	0	Fade
34	Pixel 3 White	Intensity 0-100%	0	255	0	100	0	Fade
35	Pixel 4 Red	Intensity 0-100%	0	255	0	100	0	Fade
36	Pixel 4 Green	Intensity 0-100%	0	255	0	100	0	Fade
37	Pixel 4 Blue	Intensity 0-100%	0	255	0	100	0	Fade
38	Pixel 4 White	Intensity 0-100%	0	255	0	100	0	Fade
39	Pixel 5 Red	Intensity 0-100%	0	255	0	100	0	Fade
40	Pixel 5 Green	Intensity 0-100%	0	255	0	100	0	Fade
41	Pixel 5 Blue	Intensity 0-100%	0	255	0	100	0	Fade
42	Pixel 5 White	Intensity 0-100%	0	255	0	100	0	Fade
43	Pixel 6 Red	Intensity 0-100%	0	255	0	100	0	Fade
44	Pixel 6 Green	Intensity 0-100%	0	255	0	100	0	Fade
45	Pixel 6 Blue	Intensity 0-100%	0	255	0	100	0	Fade
46	Pixel 6 White	Intensity 0-100%	0	255	0	100	0	Fade
47	Pixel 7 Red	Intensity 0-100%	0	255	0	100	0	Fade
48	Pixel 7 Green	Intensity 0-100%	0	255	0	100	0	Fade
49	Pixel 7 Blue	Intensity 0-100%	0	255	0	100	0	Fade
50	Pixel 7 White	Intensity 0-100%	0	255	0	100	0	Fade

## 13. Service



**Warning!** There are no user-serviceable parts inside the fixture. Opening the fixture can compromise its IP65 rating and cause damage that is not covered by the product warranty. Any service operation that requires removal of a cover must be performed by a professional service technician with the tools, skills, and personal protective equipment to maintain high-powered lighting equipment safely and efficiently.

### **Cleaning**

EXO Wash 30 fixtures require occasional cleaning to prevent the buildup of dust, dirt, and residue from atmospheric effects. Failure to keep the fixture clean will significantly reduce light output and may cause heat buildup and damage that is not covered by the product warranty. Regular cleaning will ensure maximum performance and reliable operation.

The cleaning schedule depends on the operating environment. Check fixtures regularly for signs of dirt buildup.

You can clean the fixture using a soft cloth slightly dampened with a household or automotive glass cleaning product. Do not apply pressure to the clear front or display on the back of the fixture, as you may scratch these surfaces.

Use the tilt lock mechanism to hold the head in a vertical position for easier cleaning.

### **GLP Service and Support**

Contact information for the nearest GLP Service and Support is available online at [www.glp.de/en/service](http://www.glp.de/en/service), by email at [info@glp.de](mailto:info@glp.de), or by telephone at the following numbers:

- GLP Germany: +49 (7248) 927 19-55
- GLP N. America: +1 818 767-8899
- GLP UK: +44 1392 690140
- GLP Asia: +852 (3151) 7730
- GLP Nordic: +46 737 57 11 40



## 14. Technical specifications

### Optics

Light source: 7x 40W Osram RGBW LEDs  
Lifetime: 20 000 hrs. approx. to > 70% luminous output  
Luminous flux: 40995 lux @ 3 m, 14758 lux @ 5 m  
Beam angle (half peak): 4° to 54°

### Control

Control systems: DMX, RDM, Manual setting  
DMX channel footprint: 13 / 22 / 37 / 50 depending on mode  
Setting and addressing: Onboard control panel with LCD display, RDM  
DMX compliance: USITT DMX512  
RDM compliance: ANSI/ESTA E1.20  
Pan range: 630°, 16 bit resolution  
Tilt range: 267°, 16 bit resolution

### Installation

Options: Stand on horizontal surface, suspended using truss mount brackets  
Operating position: Any  
Minimum distance to combustible materials: 0.5 m (20 in.)  
Minimum distance to illuminated surfaces: 0.5 m (20 in.)  
Installation environment: Temporary or permanent indoor installation, temporary outdoor installation  
Secondary attachment: Slot for safety cable attachment

### Electrical

AC mains power: 100-240 V nominal, 50/60 Hz  
Power supply unit: Auto-ranging electronic switch mode  
Maximum power consumption, all LEDs at 100% output: 300 W

#### **Maximum permitted number of fixtures daisy-chained to power**

4 x EXO Wash 30 total @ 100-120 V, 60 Hz  
8 x EXO Wash 30 total @ 200-240 V, 50 Hz

### Connections

AC mains power in and thru (out): Neutrik powerCON TRUE1 with sealing cap  
Control data in and thru (out): Neutrik 5-pin XLR with sealing cap

### Construction

Ingress protection rating: IP65  
Fixture housing: Aluminum, plastic  
Color: Black

### Thermal

Cooling: Fan, Convection  
Minimum ambient temperature: -10° C (14° F)  
Maximum ambient temperature: 40° C (104° F)

## **Included items**

Power cable with Neutrik powerCON TRUE1 mains input plug

## **Dimensions and weight**

Length: 279mm / 11.0 ins.

Width: 380 mm / 15.0 ins.

Height: 521 mm / 20.5 ins.

Weight: 19.7 kg (43.4 lbs.)

### 15. Dimensions

All dimensions are in millimeters

