

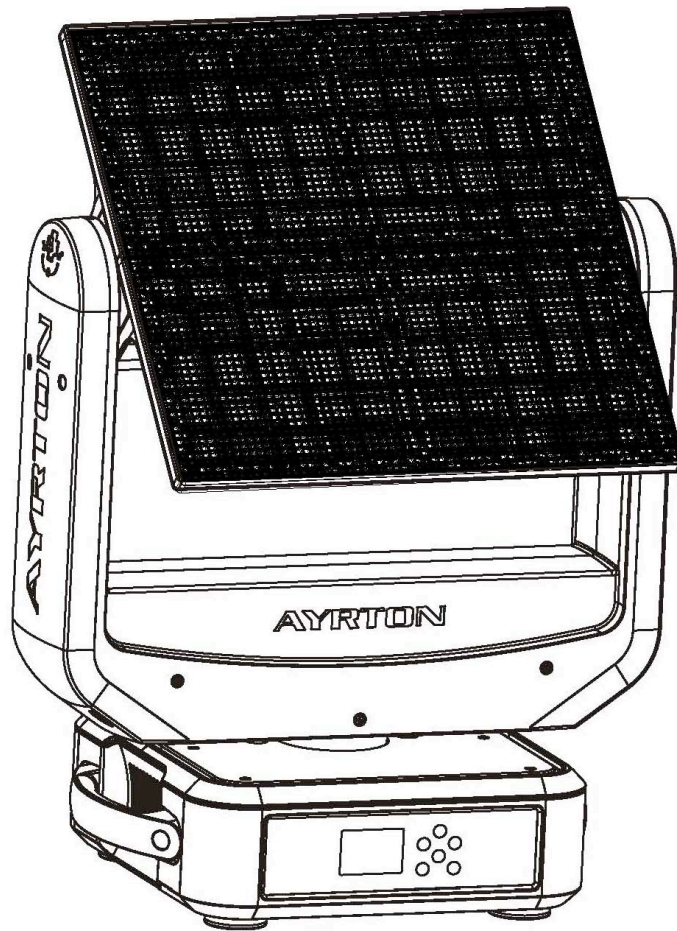

Manuel d'utilisation



dreampanel
shift

KEEP THIS MANUAL FOR FUTURE NEEDS





Contents

1. Features	2
2. Fixture Overview	3
3. SAFETY INSTRUCTIONS	3
3.1) Important safety warns	3
3.2) GENERAL GUIDELINES	4
4. INSTALLATION INSTRUCTIONS	5
4.1) Mounting the device	5
5. Cable Connection	8
6. Connection of PC and Controller	9
7. Control Board	10
7.1 Address	11
7.1.1 Set DMX Addr	11
7.2 Users mode	11
7.2.1 User mode	11
7.2.2 Edit User	12
7.3 Options	12
7.3.1 Status	12
7.3.2 Service PIN	13
7.3.3 Fans Control	13
7.3.4 Disp. Setting	13
7.3.5 Set Universe	14
7.3.6 Initial Pos.	14
7.3.7 Trigger	14
7.3.8 ResetDefault	15
7.4 Info	15
7.4.1 Time info.	15
7.4.2 Temp. Info	16
7.4.3 Software Ver	16
7.4.4 Network	16
7.5 Test	16
7.5.1 Home	16
7.5.2 Test Channel	16
7.5.3 Manual Ctrl.	17
7.5.4 Calibration	17
7.6 Preset	17
7.6.1 Select Prog.	17
7.6.2 Edit Prog.	17
7.6.3 Edit Scenes	17
7.6.4 Scenes Input	17
8. INSTRUCTIONS ON USE:	19
9. ERROR MESSAGE	20
10. CLEANING AND MAINTENANCE	20
11. TECHNICAL SPECIFICATIONS	21

Thank you for your patronage. We are confident that our excellent products and service can satisfy you. For your own safety, please read this user manual carefully before installing the device.

In order to install, operate, and maintain the lighting safely and correctly. We suggest that the installation and operation should be done by the verified technician and follow the instructions strictly.

	CAUTION! Keep this device away from rain and moisture !
	CAUTION! Unplug mains lead before opening the housing.

Every person involved with the installation, operation and maintenance of this device has to:
-be qualified
-follow carefully the instructions of this manual

INTRODUCTION:

Thank you for having chosen this professional moving head.
You will see you have acquired a powerful and versatile device.

Unpack the device. Inside the box you should find:

1. One safety rope
2. Manual
3. Two omega clamps

Please check carefully that there is no damage caused by transportation. Should there be any, consult your dealer and don't install this device.

1. Features

- Extremely Long Life:100,000 Hr and low power consumption
- 2 DMX channel mode: 8/6 channels
- Pan/tilt movement: 8 bit and 16 bit resolution
 - For smooth and precise resolution
 - Pan: 540°/630° optional, Tilt: 265°movement
 - High speed of pan/tilt movement, speed of pan/tilt movement is adjustable
 - Scan position memory, auto reposition after unexpected movement
- Control board with full color LCD graphic display and touch-keyboard
- Display: Can be changed 180° reverse to fit for different installation position.
- Rechargeable Back up Battery for Display
 - Software-upload by optional accessory via DMX line

2. Fixture Overview

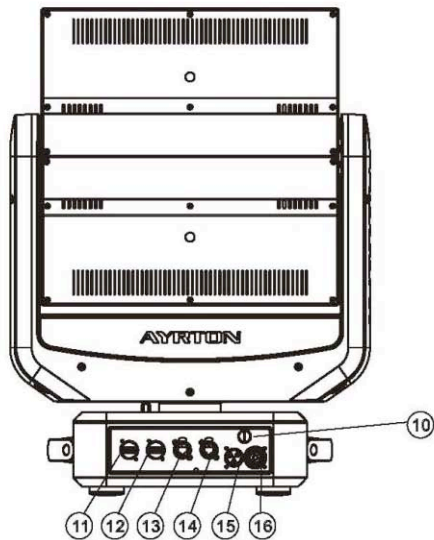
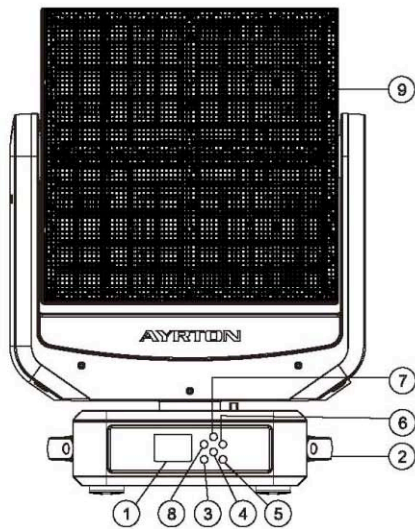

- 1: Display
- 2: Handle
- 3: Mode/Esc-button
- 4: Down-button
- 5: ENTER-button
- 6: Right-button
- 7: Up-button
- 8: Left-button
- 9: Lens
- 10: Fuse
- 11: HDMI out
- 12: HDMI in
- 13: RJ45 out
- 14: RJ45 in
- 15: Power in
- 16: Power out

3. SAFETY INSTRUCTIONS

3.1) Important safety warns

	<p>CAUTION! Be careful with your operations. With a dangerous voltage you can Suffer a dangerous electric shock when touching wires!</p>
---	---

This device has left the factory in perfect condition. In order to maintain this condition and to ensure a safe operation, it is absolutely necessary for the user to follow the safety instructions and warning notes written in this user manual.

Important:



Damages caused by the disregard of this user manual are not subject to warranty. The dealer will not accept liability for any resulting defects or problems.

If the device has been exposed to temperature changes due to environmental changes, do not

switch it on immediately. The arising condensation could damage the device. Leave the device switched off until it has reached room temperature.

This device falls under protection-class I. Therefore it is essential that the device be earthed.

If protection screen, lens or ultraviolet screen in the fixture is apparently damaged or is damaged to exceed their own effective degree, such as cracked and gashed, it must be replaced.

The electric connection must carry out by qualified person.

Make sure that the available voltage is not higher than stated at the end of this manual.



Make sure the power cord is never crimped or damaged by sharp edges. If this would be the case, replacement of the cable must be done by an authorized dealer.

Always disconnect from the mains, when the device is not in use or before cleaning it. Only handle the power cord by the plug. Never pull out the plug by tugging the power cord.

During initial start-up some smoke or smell may arise. This is a normal process and does not necessarily mean that the device is defective, it should decrease gradually.

Please don't project the beam onto combustible substances.

If the external flexible cable or cord of this luminaire is damaged, it shall be exclusively replaced by the manufacturer or his service agent or a similar qualified person in order to avoid a hazard.

	CAUTION! Never touch the device during operation! The housing may heat up
	CAUTION! Never look directly into the light source, as sensitive persons may suffer an epileptic shock.

Please be aware that damages caused by manual modifications to the device are not subject to warranty. Keep away from children and non-professionals.

3.2) GENERAL GUIDELINES

This device is a lighting effect for professional use on stages, in discotheques, theatres, etc., the device was designed for indoor use only.

This fixture is only allowed to be operated with the max alternating current which stated in the technical specifications in the last page of this manual.

Lighting effects are not designed for permanent operation. Consistent operation breaks may ensure that the device will serve you for a long time without defects.

Do not shake the device. Avoid brute force when installing or operating the device.

While choosing the installation-spot, please make sure that the device is not exposed to extreme heat, moisture or dust. Please don't project the beam onto combustible substances. The minimum distance between light-output from the projector and the illuminated surface must be more than 0.5 meter.

If you use the quick lock cam in hanging up the fixture, please make sure the quick lock fasteners turned in the quick lock holes correctly.

Operate the device only after having familiarized with its functions. Do not permit operation by persons not qualified for operating the device. Most damages are the result of unprofessional operation.

Please use the original packaging if the device is to be transported.

For safety reasons, please be aware that all modifications on the device are forbidden.

If this device will be operated in any way different to the one described in this manual, the product may suffer damages and the guarantee becomes void. Furthermore, any other operation may lead to short-circuit, burns, electric shock, lamp explosion, crash, etc.

4. INSTALLATION INSTRUCTIONS

	<p style="text-align: center;">CAUTION! Do not operate this device with open cover</p>
---	---

4.1) Mounting the device

	<p style="text-align: center;">CAUTION! Please consider the GB7000.1-2007,GB7000.217-2008 and the other respective national norms during the installation. The installation must only be carried out by a qualified person.</p>
--	--

The applicable temperature for the lighting is between -10°C to 45°C. Do not use the lighting under or above the temperature.

The installation of the effect has to be built and constructed in a way that it can hold 10 times the weight for 1 hour without any harming deformation.

The installation must always be secured with a secondary safety attachment, e.g. an appropriate safety rope.

Never stand directly below the device when mounting, removing or servicing the fixture.

The operator has to make sure the safety relating and machine technical installations are approved by an expert before taking the device into operation for the first time.

These installations have to be approved by a skilled person once a year.

Overhead mounting requires extensive experience, including amongst others calculating working load limits, installation material being used, and periodic safety inspection of all installation material and the device. If you lack these qualifications, do not attempt the installation yourself. Improper installation can result in bodily injury.

	<p style="text-align: center;">CAUTION! The electric connection must only be carried out by a qualified electrician.</p>
---	---

Before mounting make sure that the installation area can hold a minimum point load of 10 times the device's weight.

Connect the fixture to the mains with the power plug.

Installation via the Omega holders

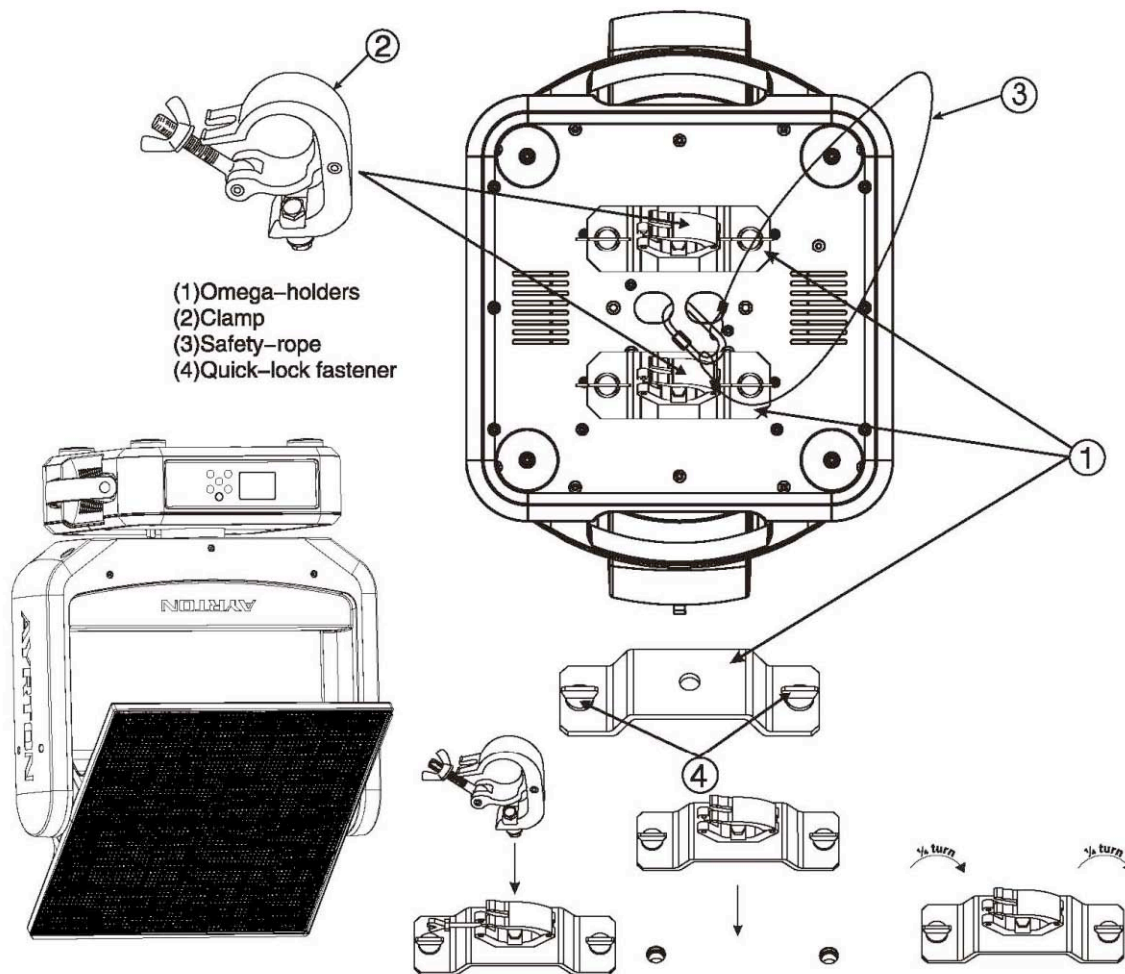

- Fixed the clamp on the bracket by tighten up the M12 screw on the bracket to the $\Phi 13$ hole in the middle of the bracket.
- Insert the quick-lock fasteners of the first Omega holder into the respective holes on the bottom of the device. Tighten the quick-lock fasteners fully clockwise.
- Install the second Omega holder.
- Pull the safety-rope through the holes on the bottom of the base and over the trussing system or a safe fixation spot. Insert the end in the carabine and tighten the safety screw.

Notice: this step is quite important to ensure that the fixture will not drop out by the damage of the clamp.

Dimensional Drawings:

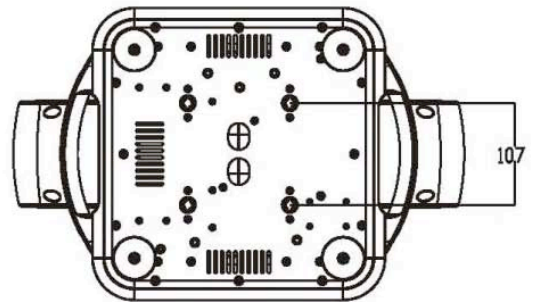
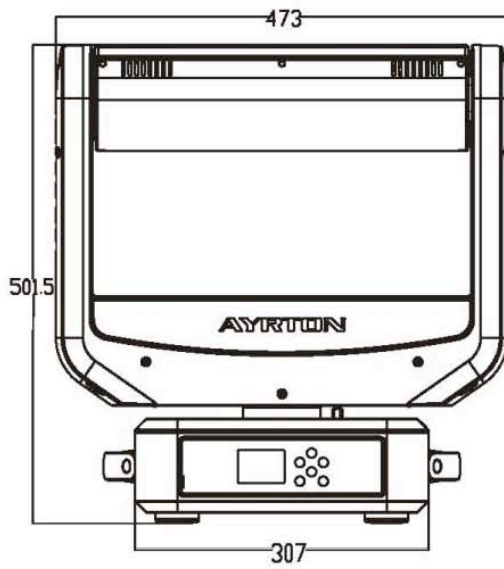
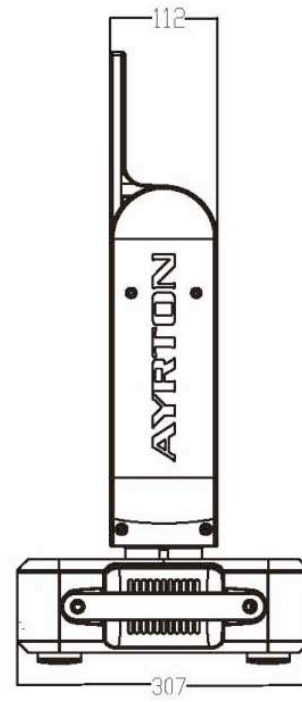
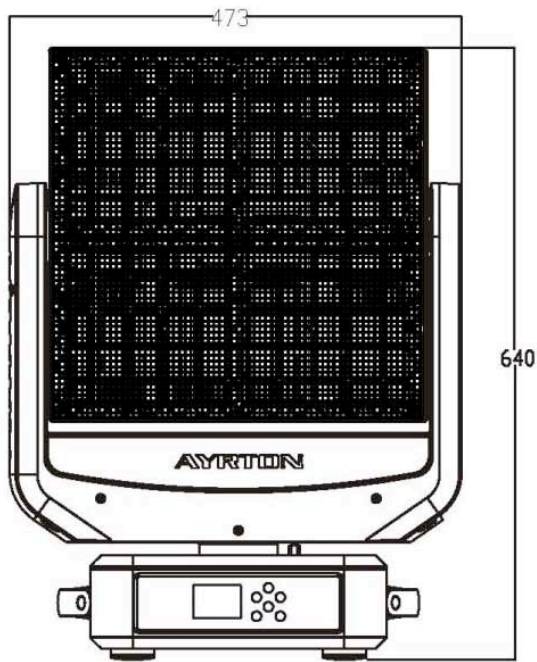

Layout Drawings:

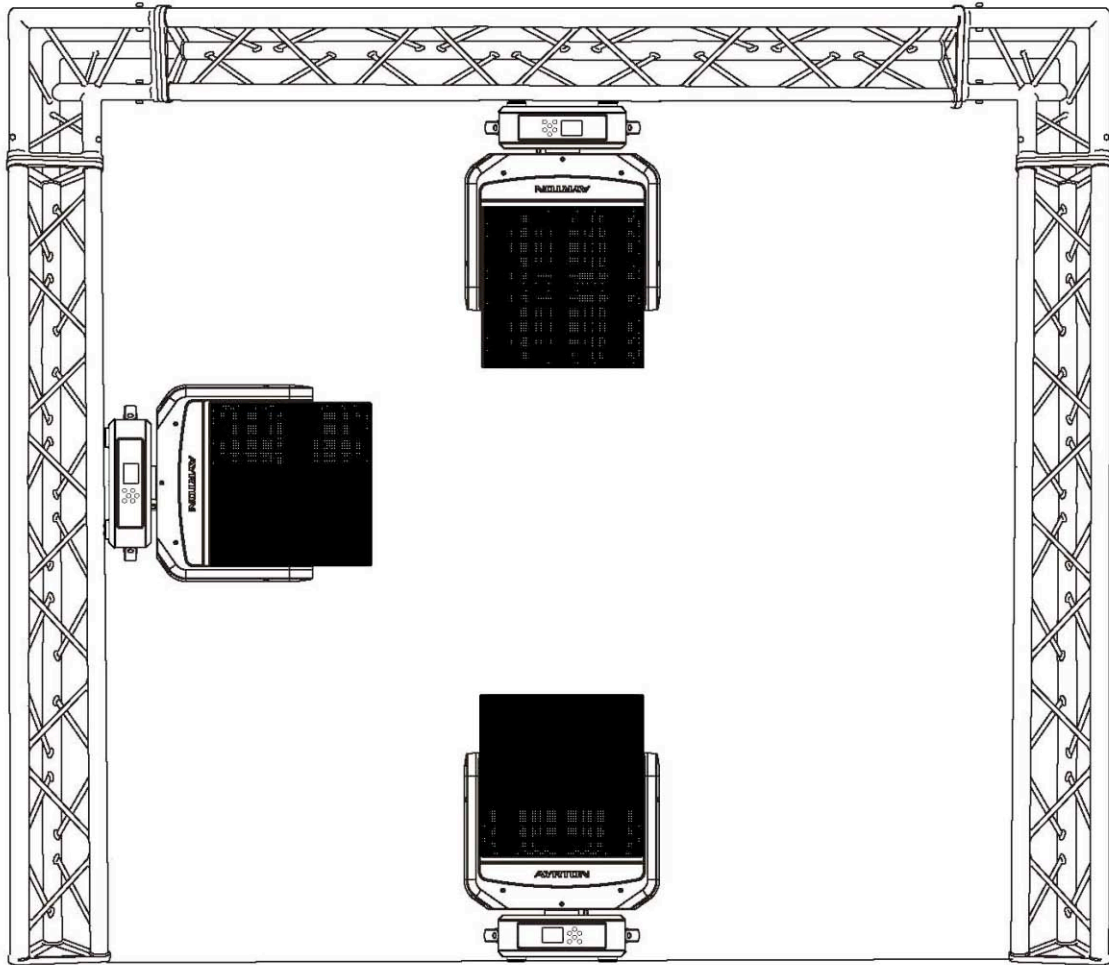

Mounting points

Be sure this fixture is kept at least 0.5m away from any flammable materials (decoration etc.). Always use and install the supplied safety cable as a safety measure to prevent accidental damage and/or injury in the event the clamp fails.

Overhead mounting requires extensive experience, including amongst others calculating working load limits, a fine knowledge of the installation material being used, and periodic safety inspection of all installation material and the fixture. If you lack these qualifications, do not attempt the installation yourself. Improper installation can result in bodily injury.

5. Cable Connection

For power connection, please follow the power in and power out indication on the structure.

For signal connection, please connect the signal cable to the output terminal of led display transmitter, all led screen are connected by signal cable.

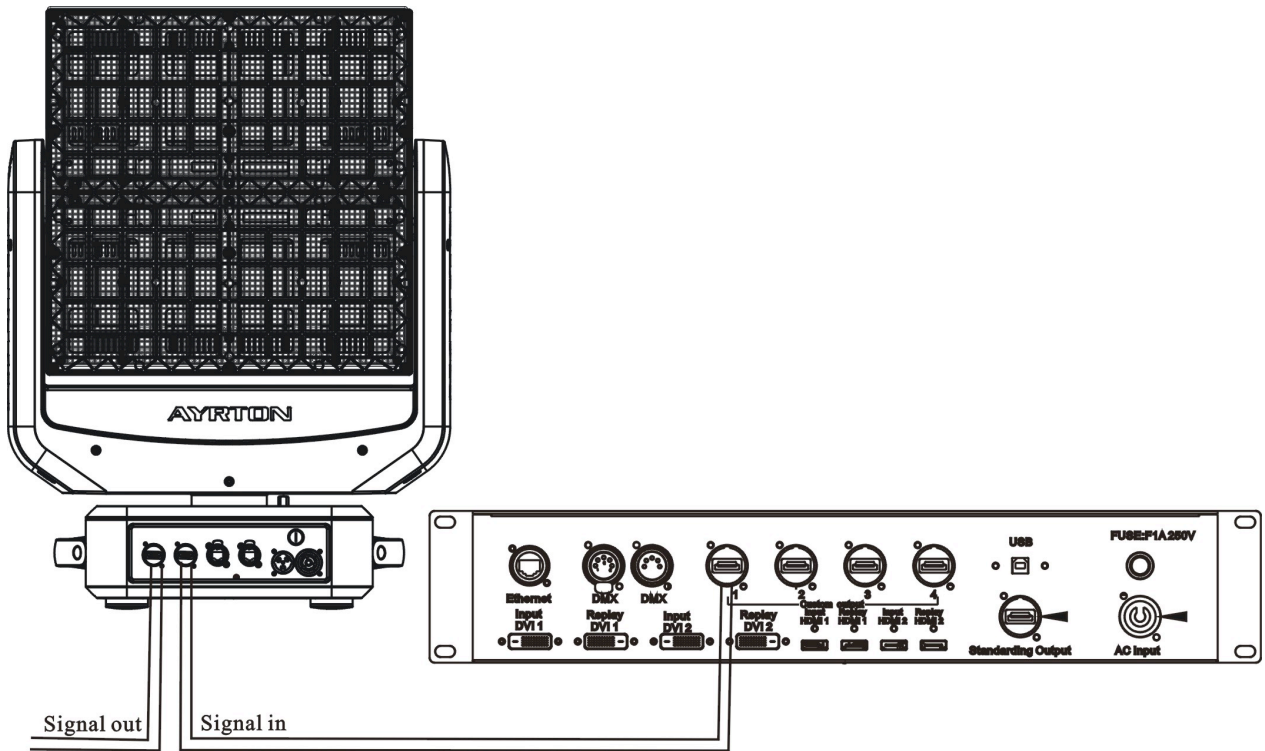

One controller have four output which is 1920(W)x1080(H) pixels

6. Connection of PC and Controller



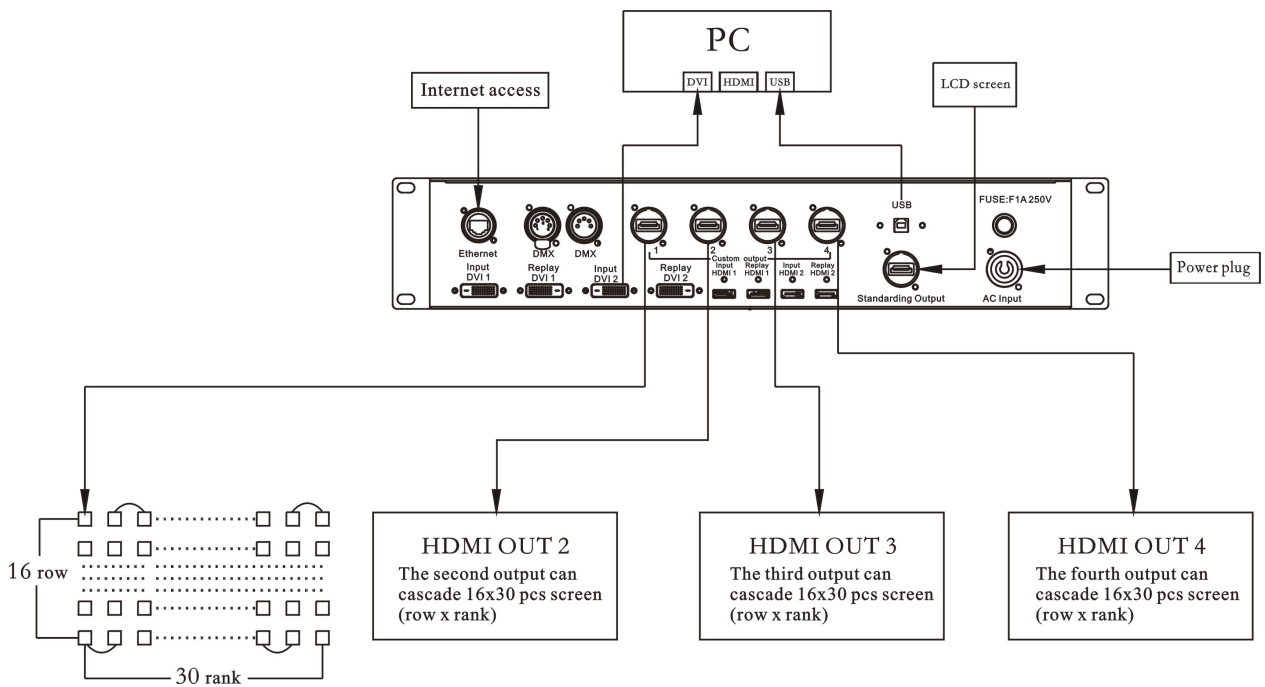

Connect the video screen controller to the DVI/HDMI terminal on PC with DVI/HDMI cable, connect the LED screen controller to USB terminal on PC with USB cable, Connect the controller's output cable to the vertical input termina of the LED color changer, see following connection diagram:



7. Control Board

The Control Board offers several features: you can simply set the starting address , run the pre-programmed program or make a reset.

The main menu is accessed by pressing the  -button until the display starts flashing.

Browse through the menu by pressing the  -button ,  -button ,  -button or  -button. Press the Enter-button in order to select the desired menu. You can change the

selection by pressing the the  -button ,  -button ,  -button or  -button.

Confirm every selection by pressing the  -button. You can leave every mode or access the

display menu via the internal battery by pressing the  -button for 5 minute; The functions provided are described in the following sections. it will exit from flash 10 seconds after the last keypress. Press this key under edit mode, . The functions provided are described in the following sections.

Address	Set Dmx Addr	A001~AXXX		DMX address setting
Users Mode	User Mode	Stand Mode Basic Mode User Mode A User Mode B User Mode C		User's mode to change channel numbers
	Edit User	Max channel PAN :		Preset User modes :
Options	Status	Pan Reverse Tilt Reverse Pan Degree Feedback Pan/Tilt Spd Hibernation	ON/OFF ON/OFF 630/540 ON/OFF Speed 1~ 4 OFF, 01M~99M	Pan Reverse movement Tilt Reverse movement Pan Degree Select Movement Feedback Reset Pan/Tilt Stand by Mode
	Service PIN	Service PIN RDM PID Set IP	Password=XXX xxxxxx xxx.xxx.xxx.xxx	Service Password“=050” RDM PID Code IP Addr
	Fans Control	Auto Stage Studio		Head Fans Speed Mode Select
	Disp.Setting	Shutoff Time Flip Display Key Lock DispFlash	02~60m 05m ON/OFF ON/OFF ON/OFF	Display shutoff time Reverse 180 degree Key Lock No Signal Rash
	Set Universe	xx		Art-Net Universe NO.
	Initial Pos.	PAN =XXX		Initial effect position
	Trigger	DMX Value Disp.	PAN.....	DMX value display

	ResetDefault	ON/OFF	Restore factory set.
Info	Time Info.	Current Time Ttl Life Hrs Last Run Hrs Timer PIN Clr Last Run	XXXX(Hours) XXXX(Hours) XXXX(Hours) Password=XXX ON/OFF
	Temp. Info	Head Temp.	XXX□/□
	Software Ver	Ver 1.0.....	Software version
	Network	IP,Mask,Mac	Network setting
Test	Home	All Pan&Tilt	Reset all motors Reset Pan/Tilt
	Test Channel	PAN	Test function
	Manual Ctrl.	PAN =XXX :	Fine adjustment of the lamp
	Calibration	-Password- PAN :	Password "050" Calbrate and adjust the effects to standard/right position
Preset	Select Prog.	Prog. Part 1 = Program 1 ~ 10 Program 1 Prog. Part 2 = Program 1 ~ 10 Program 2 Prog. Part 3 = Program 1 ~ 10 Program 3	Select programs to be run
	Edit Prog.	Program 1 : Program 10	Program Test Step 01=SCxxx Step 64=SCxxx
	Edit Scenes	Edit Scene 001 ~ Edit Scene 250	Pan,Tilt,..... --Fade Time-- --Secne Time-- Input By Outside
	Scenes Input	XX~XX	Automat. scenes rec

Default settings shaded

7.1 Address

7.1.1 Set DMX Addr

With this function, you can adjust the desired DMX-address via the Control Board.

1. Access the main menu.
2. Tap the <Up/Down>button until "Set DMX Addr" is displayed.
3. Press ENTER, the display will show "Set DMX Addr" .
4. Tap the <Up/Down>button, the display will show "A001~AXXX"
5. Press ENTER to confirm or press <MODE/ESC> to return to the main menu.

7.2 Users mode

In this menu, user can select different channels list by different sequence:

For example, after the user enter this manual, if select Auto Program = CH 22, means in this User's mode, the "Dimmer" is in Channel 16.

7.2.1 User mode

With this function, you can create user defined channel orders.

7.2.2 Edit User

With this function, you can adjust the rest user defined channel order.

1. Access the main menu.
2. The display show “Edit User” frist channel, Press <Up/Down> the display will show “Edit User” .
3. Press <ENTER> to confirm or press <MODE/ESC> to return to the main menu.

7.3 Options

7.3.1 Status

Pan Reverse

With this function you can reverse the Pan-movement.

1. Access the main menu.
2. Press <Up/Down>, the display will show “Pan Reverse” .
3. Press< ENTER>, the display will show “Pan Reverse” .
4. The display show “OFF” ,Press <Up/Down>, the display will show “ON” .
5. Press <ENTER> to confirm or press <MODE/ESC> to return to the main menu.

Tilt Reverse

With this function you can reverse the Tilt-movement.

1. Access the main menu.
2. Press <Up/Down>, the display will show “Tilt Reverse” .
3. Press< ENTER>, the display will show “Tilt Reverse” .
4. The display show “OFF” ,Press <Up/Down>, the display will show “ON” .
5. Press <ENTER> to confirm or press <MODE/ESC> to return to the main menu.

Pan Degree

With this function, you can select pan degree for 630 or 540.

1. Access the main menu.
2. Press <Up/Down>, the display will show “Pan Degree” .
3. Press< ENTER>, the display will show “Pan Degree” .
4. The display show “540” ,Press <Up/Down>, the display will show “630” .
5. Press <ENTER> to confirm or press <MODE/ESC> to return to the main menu.

Feedback

With this function, you can feedback switch of pan movement or tilt movement.

1. Access the main menu.
2. Press <Up/Down>, the display will show “Feedback” .
3. Press< ENTER>, the display will show “Feedback” .
4. The display show “ON” ,Press <Up/Down>, the display will show “OFF” .
5. Press <ENTER> to confirm or press <MODE/ESC> to return to the main menu.

Pan/Tilt Spd

With this function, you can select scan mode from 1 to 4.

1. Access the main menu.
2. Press <Up/Down>, the display will show “Pan/Tilt Spd” .
3. Press< ENTER>, the display will show “Pan/Tilt Spd” .
4. The display show “Speed 1” ,Press <Up/Down>, the display will show “Speed 2”, “Speed 3”, “Speed 4”.
5. Press <ENTER> to confirm or press <MODE/ESC> to return to the main menu.

Hibernation —Standby mode

The lamp and step motors will be power off if the fixture stay without DMX signal for 15 mins (Factory default).And the fixture will be reset before working once it receive DMX signal again.

1. Access the main menu.
2. Press <Up/Down>, the display will show “Hibernation” .
3. Press< ENTER>, the display will show “Hibernation” .
4. The display show “15M” ,Press <Up/Down>, the display will show “01M”, “02M” “99M” or “OFF” .
5. Press <ENTER> to confirm or press <MODE/ESC> to return to the main menu.

7.3.2 Service PIN

Service PIN—The Password for this function is “50”.

RDM PID— With this function you can call up various submenus via RDM.

This device is RDM ready. RDM stands for "remote device management" and makes remote control of devices connected to the DMX-bus. ANSI E1.20-2006 by ESTA specifies the RDM standard as an extension of the DMX512 protocol.

Manual settings like adjusting the DMX starting address are no longer needed. This is especially useful when the device is installed in a remote area.

RDM ready and conventional DMX devices can be operated in one DMX line. The RDM protocol sends own packages in the DMX512 data feed and does not influence conventional devices.

If DMX splitters are used and RDM control is to be used, these splitters must support RDM. The number and type of RDM parameters depend on the RDM controller being used.

Set IP

1. Access the main menu.
2. Press <Up/Down>, the display will show “Set IP” .
3. Press< ENTER>, the display will show “Set IP” .
4. The display show “xxx.xxx.xxx.xxx”
5. Press <ENTER> to confirm or press <MODE/ESC> to return to the main menu.

7.3.3 Fans Control

Head Control

With this function, you can set the speed of the running fans. The selections have Auto、High and Low.

1. Access the main menu.
2. Press <Up/Down>, the display will show “Head Control” .
3. Press< ENTER>, the display will show “Head Control” .
4. The display show“ Auto” ,Press <Up/Down>, the display will show “Stage”, “Studio”.
5. Press <ENTER> to confirm or press <MODE/ESC> to return to the main menu.

7.3.4 Disp.Setting

Shutoff Time

With this function you can shut off the color LCD display after 2 to 60 minutes. Turn the encoder in order to select the desired shut off time. The default is 5 minute.

Flip Display

With this function you can the entire display to be flipped by 180° to allow for better view when the fixture is hung from truss or a ceiling. This function is disabled as default.

1. Access the main menu.
2. Press <Up/Down>, the display will show “Flip Display” .
3. Press< ENTER>, the display will show “Flip Display” .
4. The display show “OFF” ,Press <Up/Down>, the display will show “ON” .
5. Press <ENTER> to confirm or press <MODE/ESC> to return to the main menu.

Key Lock

With this function you can activate the automatic keylock status. If this function is activated, the keys will be locked automatically after exiting the edit mode for 15 seconds. keeping press the [MENU] key for 3seconds if you do not need this function.

1. Access the main menu.
2. Press <Up/Down>, the display will show “Key Lock” .
3. Press< ENTER>, the display will show “Key Lock” .
4. The display show “OFF” ,Press <Up/Down>, the display will show “ON” .
5. Press <ENTER> to confirm or press <MODE/ESC> to return to the main menu.

DispFlash

With this function you can the entire display to be flipped by 180° to allow for better view when the fixture is hung from truss or a ceiling. This function is disabled as default.

1. Access the main menu.
2. Press <Up/Down>, the display will show “DispFlash” .
3. Press< ENTER>, the display will show “DispFlash” .
4. The display show “OFF” ,Press <Up/Down>, the display will show “ON” .
5. Press <ENTER> to confirm or press <MODE/ESC> to return to the main menu.

7.3.5 Set Universe

1. Access the main menu.
2. Press <Up/Down>, the display will show “Set Universe” .
3. Press< ENTER>, the display will show “Set Universe” .
4. The display show “xxx” .
5. Press <ENTER> to confirm or press <MODE/ESC> to return to the main menu.

7.3.6 Initial Pos.

With this function, Display initial effect position.

1. Access the main menu.
2. Press <Up/Down>, the display will show “Initial Pos.” .
3. Press< ENTER>, the display will show “Initial Pos.” .
4. The display show “XXX” .
5. Press <ENTER> to confirm or press <MODE/ESC> to return to the main menu.

7.3.7 Trigger

DMX Value Disp.

With this function you can display the DMX 512 value of each channel. The display automatically shows the channel with a value changing.

1. Access the main menu.
2. Tap the <Up/Down>button until “DMX Value Disp.” is displayed.
3. Press ENTER, the display will show “DMX Value Disp.” .

4. Tap the <Up/Down>button, choose each channel.
5. Press ENTER to confirm or press <MODE/ESC> to return to the main menu.

7.3.8 ResetDefault

With this function, you can select restore factory set for ON or OFF, the default is OFF.

1. Access the main menu.
2. Press <Up/Down>, the display will show “ResetDefault” .
3. Press< ENTER>, the display will show “ResetDefault” .
4. The display show “OFF” ,Press <Up/Down>, the display will show “ON”.
5. Press <ENTER> to confirm or press <MODE/ESC> to return to the main menu.

7.4 Info

7.4.1 Time info.

Current Time

With this function, you can display the temporary running time of the device from the last power on. The display shows “XXXX”, “XXXX” stands for the number of hours. The counter is resetted after turning the device off.

1. Access the main menu.
2. Press <Up/Down>, the display will show “Current Time” .
3. Press< ENTER>, the display will show “Current Time” .
4. The display will show “XXXX” (Hours) ;
5. Press <ENTER> to confirm or press <MODE/ESC> to return to the main menu.

Ttl Life Hrs

With this function, you can display the running time of the device. The display shows “XXXX”, “XXXX” stands for the number of hours.

1. Access the main menu.
2. Press <Up/Down>, the display will show “Ttl Life Hrs” .
3. Press< ENTER>, the display will show “Ttl Life Hrs” .
4. The display will show “XXXX” (Hours) ;
5. Press <ENTER> to confirm or press <MODE/ESC> to return to the main menu.

Last Run Hrs

With this function, you can display last the running time of the lamp. The display shows “XXXX”, “XXXX” stands for the number of hours

1. Access the main menu.
2. Press <Up/Down>, the display will show “Last Run Hrs” .
3. Press< ENTER>, the display will show “Last Run Hrs” .
4. The display will show “XXXX” (Hours) ;
5. Press <ENTER> to confirm or press <MODE/ESC> to return to the main menu.

Timer PIN

With this function, you can display the timer password.

1. Access the main menu.
2. Press <Up/Down>, the display will show “Timer PIN” .
3. Press< ENTER>, the display will show “Timer PIN” . The time password is 038.
4. Press <ENTER> to confirm or press <MODE/ESC> to return to the main menu.

Clr Last Run

With this function, you can clear last run time of the fixture. The display shows “ON” or

“OFF”, Press “Enter” to confirm.

1. Access the main menu.
2. Press <Up/Down>, the display will show “Clr Last Run” .
3. At “Timer PIN” menu input right password, Press< ENTER>, the display will show “Clr Last Run” .
4. The display show “OFF” ,Press <Up/Down>, the display will show “ON” .
5. Press <ENTER> to confirm or press <MODE/ESC> to return to the main menu.

7.4.2 Temp. Info

Head Temp.

With this function you can display the temperature on the display board of the base (near CMY-filter) in Celsius.

1. Access the main menu.
2. Press <Up/Down>, the display will show “Head Temp.” .
3. Press< ENTER>, the display will show “Head Temp.” .
4. The display show “XXX ° C/ ° F”.
5. Press <ENTER> to confirm or press <MODE/ESC> to return to the main menu.

7.4.3 Software Ver

With this function, you can display the software version of the device.

1. Access the main menu.
2. Press <Up/Down>, the display will show “Software ver” .
3. Press< ENTER>, the display will show “Software ver” .
4. The display show “Ver 1.0.....”.
5. Press <ENTER> to confirm or press <MODE/ESC> to return to the main menu.

7.4.4 Network

1. Access the main menu.
2. Press <Up/Down>, the display will show “Network” .
3. At “Timer PIN” menu input right password, Press< ENTER>, the display will show “Network” .
4. The display show “IP”, Press <Up/Down>, the display will show “Mask”, “Mac”.
5. Press <ENTER> to confirm or press <MODE/ESC> to return to the main menu.

7.5 Test

7.5.1 Home

With this function you can reset the device via the Control Board. You can select the different reset functions by turning the encoder.

1. Access the main menu.
2. The display show “All” , Press <Up/Down>, the display will show “All”, “Pan&Tilt” .
3. Press <ENTER> to confirm or press <MODE/ESC> to return to the main menu.

7.5.2 Test Channel

With this function you can test each channel on its (correct) function.

1. Access the main menu.
2. Press <Up/Down>, the display will show “Test Channel” .
3. Press< ENTER>, the display will show “Test Channel” .
4. The display show “Pan Moving” frist channel, Press <Up/Down>, can choose other channel.

5. Press <ENTER> to confirm or press <MODE/ESC> to return to the main menu.

7.5.3 Manual Ctrl.

With this function, you can adjust the lamp more easily. All effects will be canceled, the shutter opens and the dimmer intensity will be set to 100 %. With the individual functions, you can focus the light on a flat surface (wall) and perform the fine lamp adjustment.

1. Access the main menu.
2. Press <Up/Down>, the display will show “Manual Ctrl.” .
3. Press< ENTER>, the display will show “Manual Ctrl.” .
4. The display show “PAN=XXX” .
5. Press <ENTER> to confirm or press <MODE/ESC> to return to the main menu.

7.5.4 Calibration

With this function, you can calibrate and adjust the effect wheels to their correct positions. The password of calibrate values is 050.

1. Access the main menu.
2. Press <Up/Down>, the display will show “Calibration” .
3. Press< ENTER>, the display will show “Calibration” .
4. The display show “Password=XXXX” .
5. Press <ENTER> to confirm or press <MODE/ESC> to return to the main menu.

7.6 Preset

7.6.1 Select Prog.

With this function, you can select the program for the Program Run.

7.6.2 Edit Prog.

With this function, you can edit the internal programs.

7.6.3 Edit Scenes

With this function, you can edit the scenes of the internal programs.

7.6.4 Scenes Input

The moving head features an integrated DMX-recorder by which you can transmit the programmed scenes from your DMX-controller to the moving head. Adjust the desired scene numbers via the encoder (from – to). When you call up the scenes at your controller, they will automatically be transmitted to the moving head.

Excursion:

A Master unit can send up to 3 different data groups to the Slave units, i.e. a Master unit can start 3 different Slave units, which run 3 different programs. The Master unit sends the 3 program parts in a continuous loop.



The Slave unit receives data from the Master unit according to the group which the Slave unit was assigned to. If e.g. a Slave unit is set to “Slave 1” in the menu “Set to Slave”, the Master unit sends “Auto Program Part 1” to the Slave unit. If set to “Slave 2”, the Slave unit receives “Auto Program Part 2”.

To start a Auto Program please proceed as follows:

1. Slave-Setting

- Select “Function Mode” by turning the encoder.
- Press the Enter button to confirm.
- Select “Set to slave” by turning the encoder.
- Press the Enter button to confirm.
- Turn the encoder to select “Slave 1”, “Slave 2” or “Slave 3”.
- Press the Enter button to confirm.
- Press the MODE/ESC button in order to return to the main menu.

2. Automatic Program Run

- Select “Function Mode” by turning the encoder.
- Press the Enter button to confirm.
- Select “Auto Program” by turning the encoder.
- Press the Enter button to confirm.
- Turn the encoder to select “Master” or “Alone”. The selection "Alone" means Stand Alone-mode and "Master" that the device is defined as master.
- Press the Enter button to confirm.
- Press the MODE/ESC button in order to return to the main menu.

3. Program selection for Auto Pro Part

- Select “Edit program” by turning the encoder.
- Press the Enter button to confirm.
- Select “Select programs” by turning the encoder.
- Press the Enter button to confirm.
- Turn the encoder to select “Auto Pro Part 1”, “Auto Pro Part 2” or “Auto Pro Part 3”, and thus select which Slave program is to be sent. Selection “Part 1” means, that the Slave unit runs the same program as the master units.
- Press the Enter button to confirm.
- Press the MODE/ESC button in order to return to the main menu.

4. Program selection for Edit Program

- Select “Edit program” by turning the encoder.
- Press the Enter button to confirm.
- Select “Edit program” by turning the encoder.
- Press the Enter button to confirm.
- Turn the encoder to select the desired program. With this function you can edit specific scenes into a specific program.
- Press the Enter button to confirm.
- Press the MODE/ESC button in order to return to the main menu.

5. Automatic Scene Recording

- Select “Edit program” by turning the encoder.
- Press the Enter button to confirm.
- Select “Edit scenes” by turning the encoder.
- Turn the encoder to select the desired scene numbers. You can program a maximum number of 250
- Press the Enter button to confirm.
- Press the MODE/ESC button in order to return to the main menu.

Example:

Program 2 includes scenes: 10, 11, 12, 13

Program 4 includes scenes: 8, 9, 10

Program 6 includes scenes: 12, 13, 14, 15

Auto Pro Part 1 is Program 2;

Auto Pro Part 2 is Program 3;
 Auto Pro Part 3 is Program 6

The 3 Slave groups run the Auto Program in certain time segments, as shown in the following picture:

Part 1:

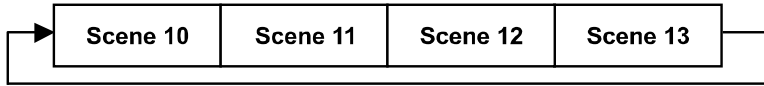

Part 2:

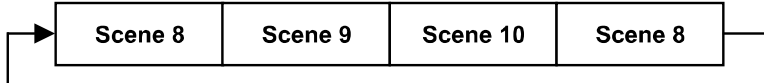

Part 3:

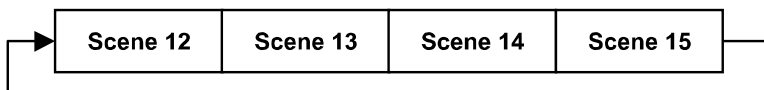

8. INSTRUCTIONS ON USE:

DMX channel's functions and their values (8 DMX channels):			
Mode/Channel		Value	Function
St	Ba		
1	1		PAN Movement 8bit :
		0-255	Pan Movement
2			Pan Fine 16bit
		0-255	Fine control of Pan movement
3	2		TILT Movement 8bit :
		0-255	Tilt Movement
4			Tilt Fine 16bit
		0-255	Fine control of Tilt movement
5	3		Speed Pan/Tilt movement:
		0-225	max to min speed
		226-235	blackout by movement
		236-255	no function
6	4		Pan Motor continuous rotation
		0-127	no function
		128-189	Forwards Pan rotation from fast to slow
		190-193	No rotation
7	5	194-255	Backwards Pan rotation from slow to fast
			Tilt Motor continuous rotation
		0-127	no function
		128-189	Forwards Tilt rotation from fast to slow

		190-193	No rotation
		194-255	Backwards Tilt rotation from slow to fast
8	6		Reset, internal programs:
		0-79	Normal
		80-84	All motor reset
		85-87	Scan motor reset
		88-90	no function
		91-93	no function
		94-96	no function
		97-99	no function
		100-119	no function
		120-139	no function
		140-159	no function
		160-179	no function
		180-199	no function
		200-219	no function
		220-239	no function
240-255	no function		

9. ERROR MESSAGE

When you turn on the fixture, it will make a reset at first. The display may show “Err channel is XX” while there are problems with one or more channels. “XX” stands for channel 1, 2, 3, 4, 5, 6 who has the testing sensor for positioning. For example, when the display shows “Err channel is Red LED -all arrays”, it means there is some error in channel 1. If there are some errors on channel 1, channel 3 at the same time, you may see the error message, “Err channel is Pan movement”, “Err channel is Tilt movement”, flash repeated for 2 times, and then the fixture will generate a second reset. If the fixture remain error message after performing reset more than 2 times, only the channels which have errors can not work properly, others can work as usual. Please contact with dealer or manufacturer for service, self repair is not allowed.

PAN- movement Er

(PAN-yoke movement error) This message will appear after the reset of the fixture if the yoke’s magnetic-indexing circuit malfunction (sensor failed or magnet missing) or the stepping-motor is defective (or its driving IC on the main PCB). The PAN- movement is not located in the default position after the reset.

TILT- movement Er

(TILT-head movement error) This message will appear after the reset of the fixture if the head’s magnetic-indexing circuit malfunctions (sensor failed or magnet missing) or the stepping-motor is defective (or its driving IC on the main PCB). The TILT- movement is not located in the default position after the reset.

10. CLEANING AND MAINTENANCE

The following points have to be considered during the inspection:

- 1) All screws for installing the devices or parts of the device have to be tightly connected and must not be corroded.
- 2) There must not be any deformations on the housing, color lenses, fixations and installation spots (ceiling, suspension, trussing).
- 3) Mechanically moved parts must not show any traces of wearing and must not rotate with

unbalances.

4) The electric power supply cables must not show any damage, material fatigue or sediments. Further instructions depending on the installation spot and usage have to be adhered by a skilled installer and any safety problems have to be removed.



CAUTION!

Disconnect from mains before starting maintenance operation.

In order to make the lights in good condition and extend the life time, we suggest a regular cleaning to the lights.

- 1) Clean the inside and outside lens each week to avoid the weakness of the lights due to accumulation of dust.
- 2) Clean the fan each week.
- 3) A detailed electric check by approved electrical engineer each three month, make sure that the circuit contacts are in good condition, prevent the poor contact of circuit from overheating.

We recommend a frequent cleaning of the device. Please use a moist, lint- free cloth. Never use alcohol or solvents.

There are no serviceable parts inside the device except for the lamp. Please refer to the instructions under “Installation instructions”.

Should you need any spare parts, please order genuine parts from your local dealer.

11. TECHNICAL SPECIFICATIONS

Power supply: AC 100-240V~, 50/60Hz

Power consumption: 120W

Packing dimensions: 56.5x37.5x74.5 cm

Net weight: ? KGS

Gross weight: ? KGS

Remark: errors and omissions for every information given in this manual excepted. All information is subject to change without prior notice.