

# User Manual

impression   
S350 WASH



Fixture software version 48



GLP® impression® S350 Wash User Manual Revision B

This document covers fixture software version 48

---

© 2018-2019 German Light Products GmbH. All rights reserved.

The marks 'GLP', 'German Light Products' and 'impression' are trademarks registered as the property of German Light Products GmbH in Germany, in the United States of America and in other countries.

The information contained in this document is subject to change without notice. German Light Products GmbH and all affiliated companies disclaim liability for any injury, damage, direct or indirect loss, consequential or economic loss or any other loss occasioned by the use of, inability to use or reliance on the information contained in this document.

Manufacturer head office:

German Light Products GmbH (GLP), Industriestrasse 2, 76307 Karlsbad, Germany  
Tel (Germany): +49 7248 92719 - 0

Service & Support EMEA:

GLP, Industriestrasse 2, 76307 Karlsbad, Germany  
Tel. (Germany): +49 7248 9271955  
Email: [support@glp.de](mailto:support@glp.de)  
[www.glp.de](http://www.glp.de)

Service & Support USA:

GLP USA, 1145 Arroyo St., Ste. A, 91340 San Fernando, California  
Tel (USA): +1 818 767 8899  
Support (US): [info@germanlightproducts.com](mailto:info@germanlightproducts.com)  
[www.germanlightproducts.com](http://www.germanlightproducts.com)

# Contents

1. Safety .....	4
2. Avoiding damage .....	9
3. Product overview .....	11
4. Product features .....	12
5. Preparation for use .....	18
6. Control menus and LCD display.....	24
7. Control menu layout .....	26
8. DMX channel layout .....	31
9. Caring for your product.....	35
10. Troubleshooting .....	36
11. Technical specifications .....	37
12. Dimensions.....	40

# 1. Safety

## Key to symbols

The following symbols are used in this manual:



**Warning!** Safety hazard.  
Risk of severe injury or death.



**Warning!** Hazardous voltage.  
Risk of lethal or severe electric shock.



**Warning!** See user manual for important safety information.



**Warning!** Fire hazard.



**Warning!** Risk of eye injury.



## General safety information

- Read this section carefully before installing or using the impression S350 Wash lighting fixture. If you have any doubts or questions about how to use the product safely, contact your GLP® supplier for assistance.
- The product and this user manual are intended for use by experienced professionals with the knowledge and skills to set up, operate, and maintain high-powered, remotely controlled lighting equipment safely and efficiently. These operations require expertise that may not be provided in this manual.
- Respect all warnings and directions given in this user manual and on the product. Read this manual and familiarize yourself with the safety precautions it contains before installing or using the product. The manufacturer will take no responsibility for damages or harm resulting from disregard for the information in this manual.
- Check the GLP website at [www.glp.de](http://www.glp.de) and make sure that you have the latest version of this user manual. Check the fixture software version indicated on page 2 of this user manual and then use the fixture's control panel to check the version installed in the fixture. If the versions are not the same, the user manual may still cover the fixture (software updates do not always affect the way you use the fixture), but it is possible that the manual does not match the fixture perfectly. The software release notes should help clarify this question. You can consult software release notes and download the correct version of this user manual on the GLP website if necessary.

- Make the user manual available to all installers and operators and save the manual for future reference.
- If you have any questions about the safe operation of the product, please contact an authorized GLP distributor (see list of distributors at [www.glp.de](http://www.glp.de)).
- Use the product only as directed in this user manual. Observe all markings in this user manual and on the product.
- Refer any service operation not described in this manual and refer all repairs to a technician authorized by GLP.
- The light source in this product must not be changed by the end user.
- Read and follow the user documentation for all additional equipment.



### **Electrical safety**

- Do not allow the product to come into contact with water or moisture.
- Use only a source of AC mains power that complies with local building and electrical codes and has both overload and ground fault (earth fault) protection.
- Ensure that the product is electrically connected to ground (earth).
- Disconnect the product from AC mains power before carrying out any installation or maintenance work and when the product is not in use.
- Disconnect the product from power immediately if the power plug or any seal, cover, cable, or other component is damaged, defective, deformed, wet or showing signs of overheating. Do not reapply power until the product has been repaired and made safe by a technician authorized by GLP.
- Before using the product, check that all power distribution equipment and cables are in perfect condition and rated for the electrical requirements of all connected devices.
- Use only a Neutrik powerCON TRUE1 cable connector for AC power input at the product's power connector.
- Use minimum 14 AWG or 1.5 mm<sup>2</sup> power input and relay cables that are minimum 16 A rated and temperature-rated to suit the application. In the USA and Canada the cables must be UL-listed, type SJT or equivalent. In the EU the cables must be type H05VV-F or equivalent.
- The supplied power input cable is rated as follows:
  - US power cable: 16 A, 14 AWG, UL listed, E304117, SJT, 4.9 ft.
  - EU power cable: 16 A, 1.5mm<sup>2</sup>, H05VV-F, 1.5 m
- If a fuse blows, replace it with one of the original type and rating only. If new fuses blow, disconnect the product from power and send it to a technician authorized by GLP for repair.



### **Fire safety and protection from burns**

- Do not operate the product if the ambient temperature (Ta) exceeds 45° C (115° F).
- The surface of the product's casing can reach up to 55° C (131° F) during operation. Avoid contact by persons and materials. Do not install the product in a location where there is a risk of accidental contact. Allow the product to cool for at least 10 minutes before handling.
- Keep the product well away from flammable materials.
- Keep all combustible materials (e.g. fabric, wood, paper) at least 200 mm (8 in.) away from the product.
- Ensure that there is free and unobstructed airflow around the product. Provide a minimum clearance of 100 mm (4 in.) around fans and air vents.
- Do not illuminate surfaces within 2 m (6.6 ft.) of the product.
- Do not install a fuse that has a higher rating than the one originally installed in the product. Do not bypass fuses.
- Do not stick filters, masks or other materials onto optical components.
- If the fixture seems to be abnormally hot, shows signs of melting or emits smoke, disconnect the fixture from power immediately and allow it to cool. Do not touch the fixture without heatproof safety gloves. Keep the fixture well away from combustible and flammable materials.
- The product's optical components can focus the sun's rays, creating a risk of fire and damage. Do not expose the front of the product to sunlight or any other intense light source, even from an angle.



### **Eye safety**

- The impression S350 Wash is classified as a Risk Group 2 product according to DIN EN 62471:2009-03. Possibly hazardous radiation emitted. Do not stare into the light output from the product. May be harmful to the eyes.
- Do not look at the product's light output with optical instruments or any device that may concentrate the light output.
- Make sure that persons working on or near the product are not looking directly into the light output when the product lights up suddenly. This can happen when power is applied, when the product receives a DMX signal, or when certain control menu items are selected.
- Provide well-lit conditions to reduce the pupil diameter of anyone working on or near the product.



### **Strobe safety**

- Flashing light, particularly at 5 - 30 Hz, may cause seizures in persons with photosensitive epilepsy. Do not use strobe effects for extended periods.
- Comply with local regulations on the use of strobe lighting and notify the public in advance with highly visible warning signs when strobe effects are used.
- If a seizure occurs, stop using strobe effects. Seek professional medical help. Note the time that the seizure starts and finishes. Call emergency medical help urgently if the seizure lasts more than five minutes, if it is the person's first seizure, or if the person is injured. While waiting for help to arrive, consider the following general advice for caring for a person who is having a seizure: protect the affected person from injuring themselves on hard or sharp objects. If necessary, move the person to a safe place. Lay them on their side with their head supported to prevent it from hitting the floor. Loosen any tight clothing around their neck. Do not use force to hold the person or restrict their movements. Do not put anything in their mouth, including your fingers.



### **Installation and operation safety**

- The fixture must be installed and operated by qualified personnel only and in accordance with applicable regulations such as DIN VDE 0711-217.
- The fixture is not portable when installed.
- Ensure that the supporting structure and installation hardware used can hold at least 10 times the weight of the load that they support.
- Install the fixture with hardware specifically designed and rated for the purpose. Check that all installation hardware is in perfect condition. Fasteners must be steel grade 8.8 strength or better. Rigging clamps must be half-coupler type that completely encircle the rigging truss chord.
- Screws or bolts used for mounting hardware must protrude minimum 9 mm / 0.36 in. and maximum 11 mm / 0.43 ins. into the threaded holes in the base of the fixture.
- If the fixture is installed in a location where it may cause injury or damage if it falls, install as directed in this manual a safety cable or similar secondary attachment that will hold the fixture if a primary attachment fails. The secondary attachment must be approved by an official body such as TÜV as a safety attachment for the weight that it secures, it must comply with EN 60598-2-17, and it must be able to support a static suspended load that is ten times the weight that it secures.
- Fasten the fixture to a structure or surface as directed in this user manual. Do not use safety cables as the primary means of support.

- Before applying power to the product, ensure that the moving head can move through its full range without risk of collision. Allow a minimum center-to-center distance of 600 mm / 23.6 in. between fixtures.
- Check that all covers and rigging hardware items are secure.
- Do not operate the product with missing or damaged covers, shields or any optical component.
- Restrict access below the work area and work from a stable platform whenever installing, servicing or moving the product.
- If the product becomes damaged, stop using it immediately and disconnect it from power. Do not attempt to use a product that is obviously damaged.
- Do not modify the product in any way not described in this user manual.
- Install genuine GLP parts only.
- If you become aware at any time that the product does not conform with one or more of the above safety requirements, disconnect the product from power and secure the affected area until the fixture is installed safely.



## 2. Avoiding damage

Do not point the front of the fixture towards the sun or other strong light sources. The front lens focuses and concentrates light just like a magnifying glass. Strong light can cause internal damage to the fixture, melting components or starting an internal fire within seconds.

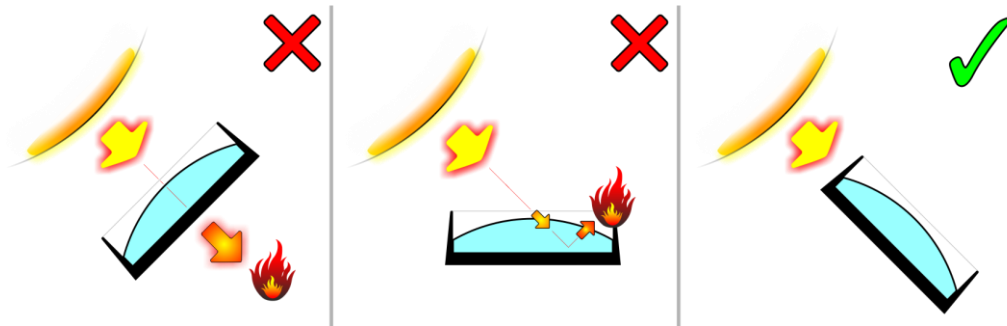

**Figure 1. Avoiding damage from light sources**

Damage can occur whether the fixture is powered on or off. See Figure 1. Damage can also occur if the light hits the front of the fixture at an angle: the fixture does not need to be pointing *directly* at the sun or other light source.

To avoid problems from strong light sources:

- Do not expose the front of a fixture to sunlight or any other strong light source.
- For outdoor applications during daylight, make sure that the front face of any fixture is shielded or points away from the sun, even when not in use.
- Avoid pointing other high-powered beam lights directly at the fixture.

Do not pick up or carry the fixture by the front lens bezel, as it is not designed to support the weight of the fixture. The LCD display is also fragile. Picking up or supporting the fixture in these places could result in damage that is not covered by the warranty.

Use only original spare parts. Any structural modification of the system will void the product warranty.

Protect the front lens from dirt, dust and other contaminants. Do not touch the front lens. Airborne particles and grease from your fingers can become baked onto the lens and difficult to remove.

Clean optical components only as directed in this manual (see 'Caring for your product' on page 35). Oils, solvents, and other chemicals commonly used for cleaning can damage the lens coatings and surfaces.

Do not drop the product or expose it to mechanical stress.

Do not expose the product to heat (from other lighting fixtures for example).

### ***Transportation and storage***

Transport the fixture either in a flightcase or in its original packaging to protect it from damage caused by shocks during transportation.

Store the fixture in a dry location where the temperature will remain above 0° C (32° F) when not in use.

**Important!** Allow the fixture to cool completely and release the tilt lock before packing or transporting the fixture in a flightcase or the original cardboard box.

### 3. Product overview

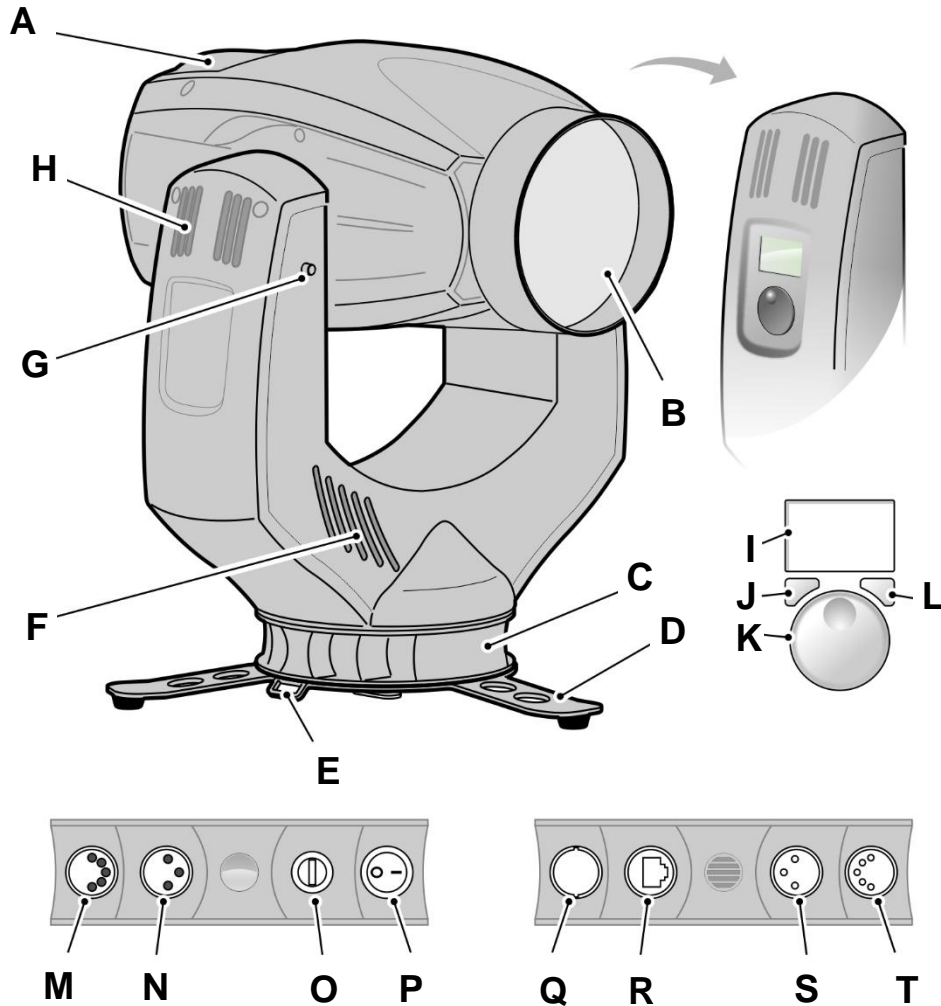

**Figure 2: Product overview**

- |   |                              |
|---|------------------------------|
| A – Head  | K – Jog wheel                |
| B – Front lens                                    | L – Enter button             |
| C – Mini-base with safety cable attachment points | M – DMX Out (thru) 5-pin XLR |
| D – Tripod stand (supplied)                       | N – DMX Out (thru) 3-pin XLR |
| E – Stabilizing strap attachment point            | O – Fuseholder               |
| F – Yoke cooling vents                            | P – Power On/Off             |
| G – Tilt lock                                     | Q – AC mains power In        |
| H – Yoke cooling vents                            | R – Ethernet Port            |
| I – Control panel display                         | S – DMX In 3-pin XLR         |
| J – Mode button                                   | T – DMX In 5-pin XLR         |

## 4. Product features

The impression S350 Wash from GLP is a high-quality moving head lighting fixture with a 350 watt white light LED engine that provides outstanding color rendering and rich, natural colors. Advanced German design allows exceptional performance and a versatile feature set to be packed into one of the most compact moving head lighting fixtures currently available, using GLP's familiar 'baseless' format. Power input via a Neutrik powerCON TRUE1 connector allows hot plugging.

The fixture is designed for permanent or temporary indoor use. It can be used outdoors if it is protected from moisture and precautions are taken to prevent damage from direct sunlight. It may be placed upright on a level surface or suspended from a suitable structure as described in this manual.

The fixture is not suitable for household use, for use in any location where unattended children have access to it, or for use in permanent outdoor installations.

### **Light source**

The impression S350 Wash is equipped with a 350 W white light LED engine with a rated lifetime of 20 000 hours to >70% LED output.

### **Control panel**

The control panel on the side of the yoke has a backlit graphic LCD display for setting up the fixture and changing fixture settings. See 'Control menu layout' on page 26 for a table showing the control menu structure and options available.

### **Control options**

The impression S350 Wash is compatible with DMX 512 and RDM control protocols.

You can control the fixture using DMX over a standard DMX cable link or via wireless DMX using a LumenRadio CRMX plug-in (optional accessory). You can also control the fixture using DMX over an Art-Net or sACN network.

See 'Setting up fixture control' on page 21 for more details.

### **Pan and tilt**

The fixture pans through 640° and tilts through 262°, with coarse and fine control channels and self-correcting position feedback available.

Pan and tilt position feedback can be disabled/enabled using the control panel or the *Special/Control* DMX channel.

The direction of pan and/or tilt movement can be reversed by selecting an *Invert* command using the fixture's control panel or the *Special/Control* DMX channel. Inverting movement is a fast way of obtaining symmetrical effects without reprogramming at the console.

## Color

The S350 Wash features 0-100% continuous CMY color mixing and a 10-slot color wheel with ten dichroic color filters including CTC (see Figure 3).

A good method of controlling color is to set CMY levels to 0% when you begin to use the color wheel. Then, after you have selected a color on the color wheel, you can fine tune it using the CMY channels.

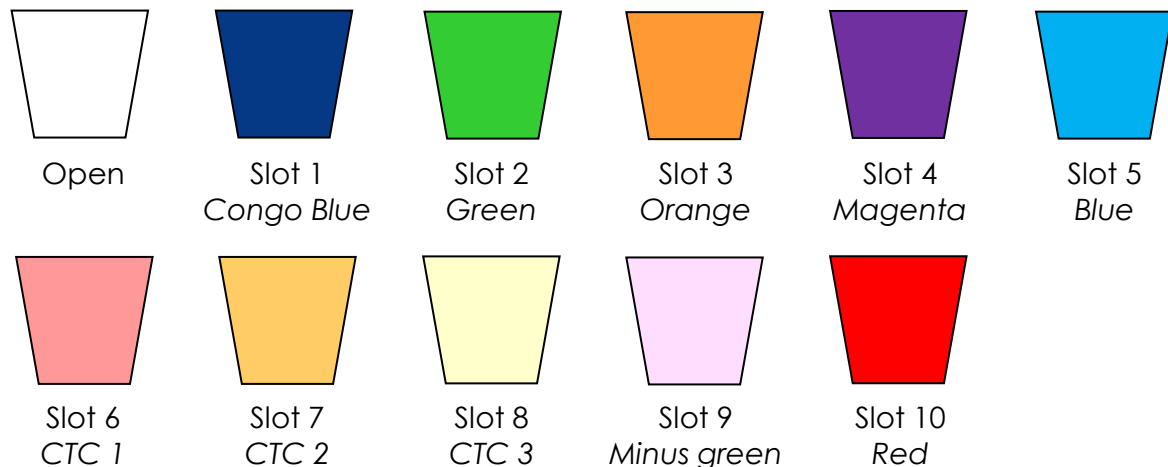

**Figure 3. Color wheel**

## CTC

The CTC DMX channel lets you adjust color temperature from 8 000 K to 2500 K by deploying the CMY flags. The channel sets the flags into the perfect positions for matching color temperatures on the black body line.

A recommended approach is to set CMY levels to 0% when you begin to use the CTC channel. After you have selected a color temperature on the CTC channel you can fine tune it using the CMY channel.

## Framing

The four-blade framing module offers individual control of each blade, and the entire module can be indexed continuously from  $-45^{\circ}$  to  $+45^{\circ}$ . Blades can be continuously angled by  $\pm 30^{\circ}$  and inserted by up to 100%, giving flexibility in choice of frame shape and size right down to dead blackout.

Two framing control modes are available:

- **PI (Position/Indexing) mode** lets you insert each blade into the beam from 0% to 100% on one channel and tilt each blade from  $-30^{\circ}$  to  $+30^{\circ}$  on the next channel. Inserting all four blades 100% into the beam will result in dead blackout. The fixture is set to PI mode by default.
- **LR (Left/Right) mode** gives you individual control of the left-hand and the right-hand sides of each of the four blades. In this mode, for example, DMX channel 25 gives control of the left-hand side of blade 1 and channel 26 gives control of the right-hand side of blade 1.

To use framing, select either PI mode (this mode is selected by default) or LR mode using either the fixture's control panel or the *Special/Control* DMX channel. Then use DMX channels 25 – 32 to control the four framing blades and use DMX channel 24 to set the indexed angle of the entire framing module.

### **Iris**

The iris gives you continuously variable control of the diameter of the beam.

### **Shutter effects**

The fixture features an electronic dimmer / shutter system that provides pulse and strobe effects as well as instant open and blackout.

### **Dimming**

0 – 100% continuous dimming is available.

See Figure 4. You can select from two dimming curves using the control panel or the *Special/Control* DMX channel: **Linear** and **Extra soft**:

- Light output using the **Linear** curve will appear to increase and decrease evenly throughout the dimming range.
- The **Extra soft** curve gives finer control at low light levels (where the eye is more sensitive to changes in light level) and coarser control at high levels.

The default setting is **Extra soft**.

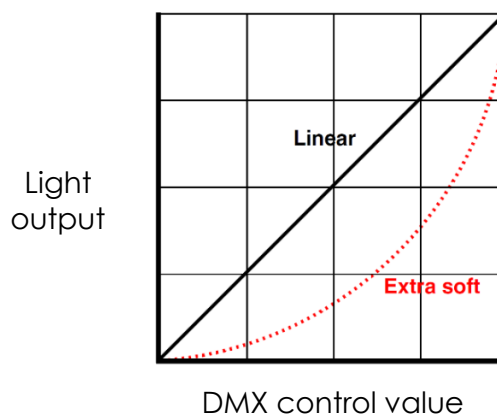

**Figure 4. Dimming curves**

### **Zoom**

The impression S350 Wash has a 1:5 zoom range. You can narrow the beam angle from 45° to 6° half-peak / narrow the field angle from 60° to 12° one-tenth peak.

Control on the Zoom DMX channel can be inverted. Normal control as the DMX value increases is *flood* → *spot*. You can invert this using the control panel and the *Special/Control* DMX channel so that control becomes *spot* → *flood*.

## Focus and focus tracking

You can adjust focus on DMX channel 13.

You can also use focus tracking, in which focus automatically adjusts to match different zoom positions. Focus tracking is enabled by default, letting you change zoom angles without any need to make adjustments on the focus channel.

It is possible to disable focus tracking completely or to optimize focus tracking for three different projection distance ranges using the fixture's control panel or the *Special/Control* DMX channel. Four focus tracking settings are available:

- **Focus tracking OFF** sets the zoom and focus DMX channels to control zoom and focus completely independently of each other.
- **Focus tracking NEAR** sets focus to automatically adjust for optimum sharpness at projection distances of around 10 meters or less when the zoom angle is changed.
- **Focus tracking MEDIUM** sets focus to automatically adjust for optimum sharpness at projection distances of around 11 - 20 meters when the zoom angle is changed. Focus tracking is set to MEDIUM by default.
- **Focus tracking FAR** sets focus to automatically adjust for optimum sharpness at projection distances of over 20 meters when the zoom angle is changed.

If you have enabled Focus tracking **NEAR**, **MEDIUM** or **FAR** you can still override the automatic focus setting: any manual adjustment that you make on the Focus DMX channel will take priority over the automatic setting. However, if you change the zoom angle again, the fixture will forget any manual focus setting and return to automatically adjusting focus to match the fixture's zoom angle.

## Fan modes

The four different cooling fan modes give you a range of options to choose from depending on how you want to allocate priority between high-intensity light output or low fan noise:

- **Fan regulated** gives priority to light output and only operates fans as necessary. If the fixture is blacked out, fans run at minimum speed. When light output intensity is increased, temperature regulation increases fan speed to the level necessary to keep the fixture at optimum temperature.

If light output is set to maximum intensity but the fans can keep the fixture at optimum temperature, there will be no regulation of light intensity. If the fixture begins to exceed optimum temperature, light intensity will be limited until optimum temperature can be maintained.

- **Fan constant high** mode is optimized for maximum light output and suits operation in high ambient temperatures. Fans are set to constant operation at high speed. Light output intensity is limited smoothly if it becomes necessary in order to keep fixture temperature at optimum level.

Besides maximizing light output in high ambient temperatures, you can use this mode to cool down a fixture quickly or to remove dust from cooling fans.

- **Fan constant medium** sets fans to constant operation at medium speed. Light output intensity is reduced to a level where it will normally remain constant at ambient

temperatures of up to 45° C (113° F). Intensity is smoothly limited further if it becomes necessary in order to keep fixture temperature at optimum level.

- **Fan constant low** mode sets fans to constant operation at low speed and is optimized for minimum noise. Light output intensity is reduced to a level where it will normally remain constant at ambient temperatures of up to 30° C (86° F). Intensity is smoothly limited further if it becomes necessary in order to keep fixture temperature at optimum level.

In all fan modes, if fixture temperature reaches a dangerous level, LEDs will be shut down for a period until the fans have brought the temperature down to a safe level.

You can set the cooling fan mode using the control panel or the *Special/Control* DMX channel.

### **Performance settings**

You can select between three different settings for the movement speed of all the fixture's mechanical effects (pan/tilt, color wheel, zoom, focus, etc.):

- In **Normal** mode, mechanical effects movement is set to give an optimum balance between speed, quietness and smoothness. Normal is the default setting.
- In **Fast** mode, movement is set to maximum speed. This setting gives super-fast effects but can result in higher noise levels.
- In **Smooth** mode, movement is set to optimize smoothness and give lowest-noise performance. This setting gives extremely low noise and smooth performance but effect movement will be slower than in Normal mode.

You can select Movement Performance using either the control panel or the *Special/Control* DMX channel.

### **Effect wheel shortcuts**

By default, the color wheel takes the shortest, fastest route from one slot to the next, even if this means that it may pass through the open position. To avoid the wheel passing through the open position when it changes from one slot to the next you can set **Effect shortcuts** on the *Special/Control* DMX channel or in the control panel to **OFF**.

### **Behavior when the fixture is not receiving a DMX signal**

You can set the fixture to react in four different ways if no DMX signal is present (if the fixture is being controlled by DMX but the DMX signal stops, or if you apply power to the fixture when no DMX signal is present):

- **Hold** sets the fixture to continue obeying the last DMX values it received. This is the default setting.
- **Blackout** sets the fixture to black out whenever it is not receiving a DMX signal.
- **Stand-Alone** sets the fixture to play its stored stand-alone scene (see **DMX Shot** below) when the fixture is not receiving a DMX signal. If no stand-alone scene is stored in memory, the fixture will black out.
- **DMX Shot** takes a snapshot of the DMX values that are currently being received and stores them in the fixture's memory as its stand-alone scene. The fixture will display this



stand-alone scene if it is set to **Stand-Alone** (see above) and is not receiving a DMX signal.

You can select one of these four settings using either the control panel or the *Special/Control* DMX channel.

### **Stand-Alone operation**

If the fixture is set to **Stand-Alone** and if a stand-alone scene has been stored in its memory using the **DMX Shot** command, it will display its stand-alone scene at all times when it is powered on but not receiving a DMX signal. You can therefore use this setting if you want fixtures to automatically start stand-alone operation when you apply power to them.

### **PWM frequency**

You can change the LED dimming PWM frequency in order to avoid flicker and beat frequencies in video images. To do this, select a new PWM frequency using either the *Settings* DMX channel or the fixture's control panel.

The default PWM setting is 3000 Hz. You can set the PWM frequency to 2200 Hz, 3000 Hz, 4800 Hz, 9600 Hz or 25 kHz. Note that a higher PWM frequency may affect dimming performance.

The PWM frequency setting is stored in the fixture and is not affected by cycling power off and on. However, it will be affected if you use the Factory default command in the control menus.

As a rule, you should set all the fixtures in an installation to the same PWM frequency in order to ensure the same performance.

### **Installation options**

The base has four Camlock fastener points and two M10 threaded holes for a removable tripod (supplied), omega brackets or direct mounting of half-coupler clamps, allowing various rigging options.

Two eyelets are provided for safety cable attachment.

See the next chapter for installation instructions.

## 5. Preparation for use



**Warning!** Read 'Safety' starting on page 4 for important safety information that you must understand before you install or operate the fixture.

### **Included Items**

The impression S350 Wash is supplied with a power cable with a powerCON TRUE1 connector and a tripod with Camlock fasteners for use as a floor stand.

### **Orientation and location**

The fixture may be rigged in any orientation following the instructions in this chapter or placed on a level surface in locations where it is safe to stand the fixture.

Keep the head at least 0.2 m (8 in.) away from combustible materials (including curtains and stage scenery) when the fixture is installed.

Make sure that there is no risk of collision when the head pans and tilts. Allow a minimum center-to-center distance of 600 mm (23.6 in.) when installing impression S350 fixtures side by side.

### **Mounting fasteners in base**

See Figure 5. The base of the fixture has two threaded holes **A** that accept M10 bolts or screws, and four mounting points **B** that accept standard camlock quarter-turn fasteners. The camlock center-to-center distance is 90 mm (3.54 in.).

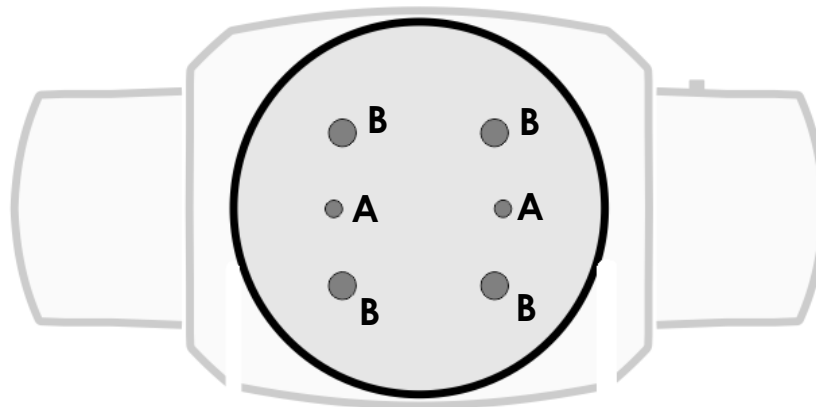
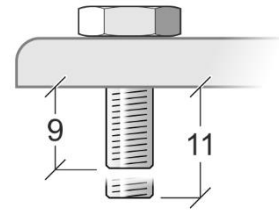

**Figure 5 Mounting points in base**

### Mounting with rigging clamps

To install the impression S350 Wash in any orientation on a rigging truss or similar support:

1. See Figure 6. Pass two M10 grade 8.8 steel bolts or screws through two half-coupler type rigging clamps and check that the bolts will protrude minimum 9 mm / 0.35 in. and maximum 11 mm / 0.43 in. into the base of the fixture when tightened.
2. See Figure 5. Fasten the bolts through the half-coupler clamps and into holes **A** in the base of the fixture so that the clamps are held securely.
3. Fasten the rigging clamps securely around a chord on a rigging truss or similar bar.
4. Secure the fixture with a safety cable as described in 'Safety attachment' on page 19.
5. Make sure that the head will not collide with another fixture or any other object when it moves through its full pan and tilt ranges.



**Figure 6. Min./max. bolt protrusion into base (millimeters)**

### Safety attachment

If there is a risk that the fixture will cause injury or damage if it falls, secure it with a secondary attachment such as a safety cable. To install a safety cable:

1. Obtain a safety cable that is approved for the load it will secure.
2. See Figure 7. Fasten the safety cable to one of the safety cable attachment points in the base of the fixture and loop it around a secure anchoring point such as a truss chord. Remove as much slack as possible in the safety cable (by looping it more than once around the truss chord, for example).
3. Secure the safety cable and check that it will hold the fixture if a primary attachment fails.



**Figure 7. Safety cable attachment points in base of fixture**

### Placing on a surface

If you install the supplied tripod on the base of the fixture, you can stand the fixture upright on a flat, stable, horizontal surface in any location where the fixture is not accessible to the public and will not present any safety risks.

If necessary to prevent the fixture from moving or falling, pass a ratchet strap, webbing or other suitable bracing strap through the safety cable attachment points in the base (see Figure 7) or the strap attachment points in the tripod stand (see Figure 8) and fasten it to secure anchoring points. Make sure that the strap is tight enough to hold the fixture, but do not distort attachment points by overtightening the strap.

If the fixture may cause injury or damage if it falls, secure it with a safety cable as described in 'Safety attachment' on page 19.

Make sure that the head will not collide with anything when it tilts and rotates.

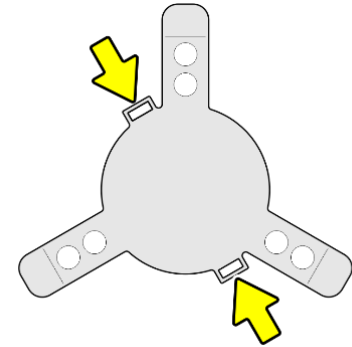

**Figure 8. Strap attachment points in tripod stand**

### Connecting to power

The AC mains power supply must include a connection to ground / protective earth. It must be protected against ground / earth leakage and overload. The auto-sensing power supply accepts AC power at 100-240 V, 50/60 Hz. Do not connect the fixture to power at any other voltage or to an external dimmer.

The S350 Wash has a 3-conductor Neutrik powerCON TRUE1 socket that accepts AC power from a Neutrik powerCON TRUE1 female cable connector.

Although powerCON TRUE1 connectors support hot-plugging, it is still good practice to shut down power to power cables or move Power ON/OFF switches to OFF before connecting power cables to fixtures.

To connect the fixture to power:

1. Check that power to the power input cable is shut down or that the fixture's power switch is set to OFF.
2. See **Q** in Figure 2 on page 11. Note the position of the keys and keyways on the power cable connector and *Mains In* socket and align them with each other. Insert the cable connector into the socket and twist clockwise to lock.
3. Before applying power by energizing the power cable and/or switching on the power switch, check that the head is unlocked and can move freely and check that nobody is looking directly into the front of the fixture.

### Installing power connectors

It is possible to install a cord cap / mains power plug that is suitable for your local convenience receptacles / power sockets on the supplied power input cable. If you do this, check that the cord cap / plug is rated minimum 250 V, 16 A, that it has a connection to ground / earth and that it has an integral cable grip. Follow the cord cap / plug manufacturer's assembly instructions.

If you need to install a Neutrik powerCON TRUE1 connector on a power cable, follow the instructions given in the Support area of the Neutrik website at [www.neutrik.com](http://www.neutrik.com).

Respect the color coding used in the supplied power cable and in your local mains power wiring system. US and EU systems use the color coding shown below:

	Live or L	Neutral or N	Ground / Earth or ⊕
<b>US system</b>	Black	White	Green
<b>EU system</b>	Brown	Blue	Yellow/green

### Main fuse

See Figure 9. The main fuse sits in a holder in the base.

If the fixture appears to be completely shut down even though power is applied, the main fuse may have blown. Disconnect the fixture from power before replacing the fuse. You can open the fuseholder with a flat-headed screwdriver. Replace only with a fuse of the same type and rating.

If the fuse blows repeatedly, disconnect the fixture from power and contact GLP for service and repair.

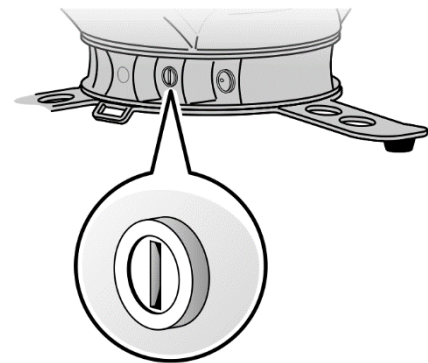

**Figure 9. Main fuse**

### Setting up fixture control

The impression S350 Wash can be controlled via USITT512 DMX over a standard DMX cable link, Art-Net network or sACN network.

If you would like any advice with planning and installing a suitable control link, your GLP supplier will be happy to provide assistance.

### DMX

The fixture has 5-pin and 3-pin XLR IN and THRU sockets for connection to a DMX cable link.

Connectors use standard DMX pinout:

- Pin 1 = Ground
- Pin 2 = Negative / data cold
- Pin 3 = Positive / data hot.
- Pins 4 and 5 are not used.

To configure the fixture for DMX control over a DMX cable link, open the menus in the fixture's control panel and make the following adjustments:

1. In the first menu (root menu), set the fixture's DMX address to a suitable address.
2. In the ArtNet/sACN menu, set **Capture Mode** to **DMX**.

These settings will not be affected if you apply a **Load Default Settings** command in the fixture's control panel, but they will be returned to factory defaults if you apply a **Load Factory Backup** command in the fixture's control panel.

To link fixtures in cabled DMX daisy-chains using their XLR connectors, use certified DMX cable only.

### Art-Net

The fixture's Ethernet port is suitable for connection to an Art-Net network.

To configure the fixture to receive control data via Art-Net, open the menus in the fixture's control panel and make the following adjustments:

1. In the first menu (root menu), set the fixture's DMX address to a suitable address.
2. In the ArtNet/sACN menu, set **Capture Mode** to **Art-Net**.
3. Configure all fixtures with their own unique IP addresses. To do this, you can either:
  - set fixtures to generate their own IP addresses by choosing the ranges 2.x.x.x or 10.x.x.x (Art-Net specification),
  - set fixtures to acquire IP addresses automatically by DHCP, or
  - assign IP addresses manually by entering individual IP addresses and Subnet mask.
4. Select an Art-Net port/universe from 00000 (Network 0 / Subnet 0 / Universe 0) to 32767 (Network 7 / Subnet 15 / Universe 255). Note that the first Art-Net universe is considered to be universe number 00000, not 00001.

These settings will not be affected if you apply a **Load Default Settings** command in the fixture's control panel, but they will be returned to factory defaults if you apply a **Load Factory Backup** command in the fixture's control panel.

Note that it is possible to transmit DMX data as broadcast or unicast packages via Art-Net. If a large number of universes (more than 30) is broadcast, data loss can occur. If you suspect that this is happening, configure your console to unicast Art-Net DMX packages to fixtures, or switch to sACN.

To link fixtures in Art-Net daisy-chains, use CAT 6 or higher Ethernet cable.

### sACN

The fixture's Ethernet port is suitable for connection to an sACN network.

To configure the fixture to receive control data via sACN, open the menus in the fixture's control panel and make the following settings:

1. In the first menu (root menu), set the fixture's DMX address to a suitable address.
2. In the ArtNet/sACN menu, set **Capture Mode** to **sACN**.

3. Configure all fixtures with their own unique IP addresses. To do this, you can either:
  - set fixtures to generate their own IP addresses by choosing the ranges 2.x.x.x or 10.x.x.x (Art-Net specification),
  - set fixtures to acquire IP addresses automatically by DHCP, or
  - assign IP addresses manually by entering individual IP addresses and Subnet mask.
4. Select an sACN universe from 00001 to 63999.

These settings will not be affected if you apply a **Load Default Settings** command in the fixture's control panel, but they will be returned to factory defaults if you apply a **Load Factory Backup** command in the fixture's control panel.

To link fixtures in sACN daisy-chains, use CAT 6 or higher Ethernet cable.

## 6. Control menus and LCD display



**Warning!** DMX control is disabled when the control menus are active. Be prepared for the head to move as soon as you exit the control menus.

The control panel and LCD display provide access to user settings, readouts, and utilities.

When power is applied, the fixture resets and **impression S350 Wash** appears in the display panel. After the reset has completed, the main menu is displayed:



**Figure 10. Control panel**

See Figure 10. From left to right, the top line of the main menu displays:

- Main CPU software version
- Pan, tilt, and zoom modes: **N** (Normal) or **I** (inverse)
- Dimming curve: **L** (Linear) or **E** (Extra Soft)
- PWM frequency.



In the example shown in Figure 10:

- The fixture is running CPU software version 0.12
- Pan, Tilt and Zoom are Normal
- Dimming is Extra-soft
- The current PWM frequency is 3000 Hz
- The fixture's DMX start address is 101, it uses DMX channels 101 – 127, and DMX channel 128 is available for use as the start address of the next device on the DMX link.

A flashing display indicates loss of DMX.

To use the control panel:

- Use the **Jog wheel** to scroll up and down through menu options.
- Press the **Enter** button to select a setting, confirm a command or enter a submenu.
- Press the **Mode** button to escape and return to the top of the menu.

## 7. Control menu layout

DMX Start Address	1 - 512	Set DMX start address	
Special	Set Dimming Mode	<b>Esoft</b>	Select dimming curve: Extra Soft / Linear
		Linear	
	Show Errors	Execute	Display any stored errors
	Framing Mode	<b>P/I</b>	Set framing control mode to Position / Indexed angle
		L/R	Set framing control mode to Left / Right
	No DMX	Blackout	Fixture blacks out if DMX signal stops
		<b>Hold</b>	Fixture continues to display current effect if DMX signal stops
		Stand Alone	Fixture displays its stand-alone scene if DMX signal stops
		DMX Shot	Fixture stores the scene it is currently displaying as its stand-alone scene
	Shortcut	<b>On</b>	Effect wheel shortcuts (pass through open)
		Off	
	Set PWM Frequency	2200 Hz	Set PWM frequency
		<b>3000 Hz</b>	
		4800 Hz	
9600 Hz			
25 kHz			
Focus Tracking Mode	Off	Set zoom / focus tracking distance	
	Near		
	<b>Medium</b>		
	Far		

Special (contd.)	Set Fan Mode	<b>Regulated (REG)</b>	Fan speed temperature-regulated
		Low	Fan speed constant: low / medium / high
		Medium	
		High	
	Set Display Mode	<b>Normal (Auto)</b>	Control panel display sleeps after 30 seconds
		On	Control panel display constantly on
		Off	Control panel display constantly off
	Set Performance Mode	Fast	Fastest mechanical effect movement
		<b>Medium</b>	Mechanical effect movement balanced for speed/ noise / smoothness
		Smooth	Smoothest mechanical effect movement
	Default	Execute	Return fixture to factory default settings
	Temperature LED	XXX°	LED PCB temperature
	Temperature main	XXX°	Main PCB temperature
	Temperature base	XXX°	Base PCB temperature
	Boot count	XXX	Number of startups since manufacture (non-resettable)
	Fixture hours	XXX	Operating hours since manufacture (non-resettable)
Version Info	Main	Fixture firmware version	
	Artnet/WDMX	Art-Net / WDMX driver version	
	LED Driver ... Color Fan Driver	Driver versions	

Special (continued)	Adjust (contd.)	Key code → Enter value	Pan Offset	Set adjustment offset values
			Tilt Offset	
			Zoom Offset	
			Focus Offset	
			Iris offset	
			Color Wheel offset	
			Cyan Offset	
			Cyan Offset fine	
			Magenta Offset	
			Magenta Offset fine	
			Yellow Offset	
			Yellow Offset fine	
			Framing Blade 1a	
			Framing Blade 1b	
			Framing Blade 2a	
			Framing Blade 2b	
			Framing Blade 3a	
Framing Blade 3b				
Framing Blade 4a				
Framing Blade 4b				
Framing Rotation				
Manual DMX	Scroll through DMX channels → Enter value	Manually control all effects		
DMX Input	Scroll through DMX channels → Press Enter to view value	See DMX values being received on each DMX channel		

Special (continued)	ArtNet/sACN	Capture Mode	<b>DMX</b>	Select control signal type
			ArtNet	
			sACN	
		ArtNet IP Mode	2.X.X.X	Fixture generates its own IP address in range 2.X.X.X or 10.X.X.X based on its MAC address
			10.X.X.X	
			Manual	Manual IP address setting: fixture uses settings entered in <i>ArtNet Manual</i> menu (see below)
			DHCP	IP address dynamically assigned by DHCP server
		ArtNet Manual	ArtNet IP1	Set 1st three digits...
			ArtNet IP2	Set 2nd three digits...
			ArtNet IP3	Set 3rd three digits...
			ArtNet IP4	Set 4th three digits... ...of Art-Net IP address
			Subnet 1	Set 1st three digits...
			Subnet 2	Set 2nd three digits...
			Subnet 3	Set 3rd three digits...
			Subnet 4	Set 4th three digits... ...of subnet
ArtNet port	Set Art-Net port (Art-Net universe)			
sACN universe	Set sACN universe			
Status	Art-Net status			
Display Flip	<b>ON / OFF</b>	Invert onboard display		
Position Feedback	<b>ON / OFF</b>	Enable/Disable Pan/Tilt position feedback		
Reverse Pan	<b>ON / OFF</b>	Invert Pan		
Reverse Tilt	<b>ON / OFF</b>	Invert Tilt		
Reverse Zoom	<b>ON / OFF</b>	Invert Zoom from Wide → Spot to Spot → Wide		
Reset Pan/Tilt only		Reset Pan and Tilt		
Reset head only		Reset effects and processes in head		
Reset		Reset entire fixture		

Default values are shown **in bold type**.

Settings that can be adjusted or functions that can be run by the user are displayed in grey boxes.



## 8. DMX channel layout

### Normal mode (27 DMX channels)

Channel	Function	Description	DMX range	Default DMX	% Range	Fade
<b>1</b>	Pan coarse	Left – right in 1.2° increments (16 bit)	0 – 65535	32767	0 – 100%	Fade
<b>2</b>	Pan fine					
<b>3</b>	Tilt coarse	Up – down in 1.2° increments (16 bit)	0 – 65535	32767	0 – 100%	Fade
<b>4</b>	Tilt fine					
<b>5</b>	Color wheel	Open	0 – 3	0	0 – 1.2%	Snap
		Color 01 – Congo blue	4 – 7		1.6 – 2.7%	Snap
		Color 02 – Green	8 – 11		3.1 – 4.3%	Snap
		Color 03 – Orange	12 – 15		4.7 – 5.9%	Snap
		Color 04 – Magenta	16 – 19		6.3 – 7.5%	Snap
		Color 05 – Blue	20 – 23		7.8 – 9.0%	Snap
		Color 06 – CTC 1	24 – 27		9.4 – 10.6%	Snap
		Color 07 – CTC 2	28 – 31		11.0 – 12.2%	Snap
		Color 08 – CTC 3	32 – 35		12.5 – 13.7%	Snap
		Color 09 – Minus green	36 – 39		14.1 – 15.3%	Snap
Color 10 – Red	40 – 43	15.7 – 16.9%	Snap			
	Color wheel indexing 0 – 360° (continuous color changing)	44 – 167	17.3 – 65.5%	Fade		
	Color wheel rotation CW fast – slow	168 – 211	65.9 – 82.7%	Fade		
	Color wheel rotation stop	212	83.1%	Snap		
	Color wheel rotation CCW slow – fast	213 – 255	83.5 – 100%	Fade		
<b>6</b>	Cyan	Cyan 0 – 100%	0 – 255	0	0 – 100%	Fade
<b>7</b>	Magenta	Magenta 0 – 100%	0 – 255	0	0 – 100%	Fade
<b>8</b>	Yellow	Yellow 0 – 100%	0 – 255	0	0 – 100%	Fade
<b>9</b>	CTC	Off	0 – 31	0	0 – 12.2%	Snap
		8000 K	32 – 35		12.5 – 13.7%	Fade
		7900 K	36 – 39		14.1 – 15.3%	
		7800 K	40 – 43		15.7 – 16.9%	
		7700 K	44 – 47		17.3 – 18.4%	
		7600 K	48 – 51		18.8 – 20.0%	
		7500 K	52 – 55		20.4 – 21.6%	
		7400 K	56 – 59		22.0 – 23.1%	
		7300 K	60 – 63		23.5 – 24.7%	
		7200 K	64 – 67		25.1 – 26.3%	
		7100 K	68 – 71		26.7 – 27.8%	
		7000 K	72 – 75		28.2 – 29.4%	
		6900 K	76 – 79		29.8 – 31.0%	
		6800 K	80 – 83		31.4 – 32.5%	
		6700 K	84 – 87		32.9 – 34.1%	
		6600 K	88 – 91		34.5 – 35.7%	
		6500 K	92 – 95		36.1 – 37.3%	
		6400 K	96 – 99		37.6 – 38.8%	
		6300 K	100 – 103		39.2 – 40.4%	
		6200 K	104 – 107		40.8 – 42.0%	
6100 K	108 – 111	42.4 – 43.5%				
6000 K	112 – 115	43.9 – 45.1%				
5900 K	116 – 119	45.5 – 46.7%				

<b>9</b> continued		5800 K	120 – 123		47.1 – 48.2%	Fade
		5700 K	124 – 127		48.6 – 49.8%	
		5600 K	128 – 131		50.2 – 51.4%	
		5500 K	132 – 135		51.8 – 52.9%	
		5400 K	136 – 139		53.3 – 54.5%	
		5300 K	140 – 143		54.9 – 56.1%	
		5200 K	144 – 147		56.5 – 57.6%	
		5100 K	148 – 151		58.0 – 59.2%	
		5000 K	152 – 155		59.6 – 60.8%	
		4900 K	156 – 159		61.2 – 62.4%	
		4800 K	160 – 163		62.7 – 63.9%	
		4700 K	164 – 167		64.3 – 65.5%	
		4600 K	168 – 171		65.9 – 67.1%	
		4500 K	172 – 175		67.5 – 68.6%	
		4400 K	176 – 179		69.0 – 70.2%	
		4300 K	180 – 183		70.6 – 71.8%	
		4200 K	184 – 187		72.2 – 73.3%	
		4100 K	188 – 191		73.7 – 74.9%	
		4000 K	192 – 195		75.3 – 76.5%	
		3900 K	196 – 199		76.9 – 78.0%	
		3800 K	200 – 203		78.4 – 79.6%	
		3700 K	204 – 207		80.0 – 81.2%	
		3600 K	208 – 211		81.6 – 82.7%	
		3500 K	212 – 215		83.1 – 84.3%	
		3400 K	216 – 219		84.7 – 85.9%	
		3300 K	220 – 223		86.3 – 87.5%	
		3200 K	224 – 227		87.8 – 89.0%	
	3100 K	228 – 231		89.4 – 90.6%		
	3000 K	232 – 235		91.0 – 92.2%		
	2900 K	236 – 239		92.5 – 93.7%		
	2800 K	240 – 243		94.1 – 95.3%		
	2700 K	244 – 247		95.7 – 96.9%		
	2600 K	248 – 251		97.3 – 98.4%		
	2500 K	252 – 255		98.8 – 100%		
<b>10</b>	Shutter	Closed	0 – 15	255	0 – 5.9%	Snap Fade
		Pulse, random, slow – fast	16 – 47		6.3 – 18.4%	
		Ramp-up, random, slow – fast	48 – 79		18.8 – 31%	
		Ramp-down, random, slow – fast	80 – 111		31.4 – 43.5%	
		Ramp-up-down, random, slow – fast	112 – 143		43.9 – 56.1%	
		Strobe with b/o pause 5 – 0.1 sec.	144 – 199		56.5 – 78.0%	
		Strobe 1 – 10 Hz	200 – 239		78.4 – 93.7%	
		Open	240 – 255		94.1 – 100%	
<b>11</b>	Dimmer coarse	Intensity 0 – 100%	0 – 65535	32768	0 – 100%	Fade
<b>12</b>	Dimmer fine					
<b>13</b>	Focus	Near – far	0 – 255	128	0 – 100%	Fade
<b>14</b>	Zoom	Wide – narrow	0 – 255	127	0 – 100%	Fade



<b>15</b>	Framing module indexing	CW indexing from 0° to -45° Center: 0° CCW indexing from 0° to +45°	0 – 128 128 129 – 255	128	0 – 50.2% 50.2% 50.6 – 100%	Fade Snap Fade
<b>16</b>	Framing blade 1 position / left	PI mode: In – out LR mode: Blade left side	0 – 255 0 – 255	0 0	0 – 100% 0 – 100%	Fade Fade
<b>17</b>	Framing blade 1 index / right	PI mode: Tilt -30° – +30° LR mode: Blade right side	0 – 255 0 – 255	128 0	0 – 100% 0 – 100%	Fade Fade
<b>18</b>	Framing blade 2 position / left	PI mode: In – out LR mode: Blade left side	0 – 255 0 – 255	0 0	0 – 100% 0 – 100%	Fade Fade
<b>19</b>	Framing blade 2 index / right	PI mode: Tilt -30° – +30° LR mode: Blade right side	0 – 255 0 – 255	128 0	0 – 100% 0 – 100%	Fade Fade
<b>20</b>	Framing blade 3 position / left	PI mode: In – out LR mode: Blade left side	0 – 255 0 – 255	0 0	0 – 100% 0 – 100%	Fade Fade
<b>21</b>	Framing blade 3 index / right	PI mode: Tilt -30° – +30° LR mode: Blade right side	0 – 255 0 – 255	128 0	0 – 100% 0 – 100%	Fade Fade
<b>22</b>	Framing blade 4 position / left	PI mode: In – out LR mode: Blade left side	0 – 255 0 – 255	0 0	0 – 100% 0 – 100%	Fade Fade
<b>23</b>	Framing blade 4 index / right	PI mode: Tilt -30° – +30° LR mode: Blade right side	0 – 255 0 – 255	128 0	0 – 100% 0 – 100%	Fade Fade
<b>24</b>	Iris	Open → closed	0 – 255	0	0 – 100%	Snap
<b>25</b>	Special / Control	No function Performance fast* <b>Performance normal*</b> Performance smooth* Nu function <b>Dimmer curve extra soft*</b> Dimmer curve linear* No function Display off* <b>Display auto-off*</b> Display on* <b>Display orientation normal*</b> Display orientation invert* No function No DMX = blackout* <b>No DMX = hold*</b> No DMX = stand-alone* No DMX = DMX shot* No function <b>Fan regulated*</b> Fan high* Fan medium* Fan low* No function Position feedback off* <b>Position feedback on*</b> Effect shortcuts off* <b>Effect shortcuts on*</b> <b>Tilt invert off*</b> Tilt invert on* <b>Pan invert off*</b> Pan invert on* <b>Zoom invert off*</b> Zoom invert on*	0 – 26 27 – 29 30 – 32 33 – 35 36 – 38 39 – 41 42 – 44 45 – 53 54 – 56 57 – 59 60 – 62 63 – 65 66 – 68 69 – 71 72 – 74 75 – 77 78 – 80 81 – 83 84 – 86 87 – 89 90 – 92 93 – 95 96 – 98 99 – 104 105 – 107 108 – 110 111 – 113 114 – 116 117 – 119 120 – 122 123 – 125 126 – 128 129 – 131 132 – 134	0	0 – 10.2% 10.6 – 11.4% 11.8 – 12.5% 12.9 – 13.7% 14.1 – 14.9% 15.3 – 16.1% 16.5 – 17.3% 17.6 – 20.8% 21.2 – 22% 22.4 – 23.1% 23.5 – 24.3% 24.7 – 25.5% 25.9 – 26.7% 27.1 – 27.8% 28.2 – 29.0% 29.4 – 30.2% 30.6 – 31.4% 31.8 – 32.5% 32.9 – 33.7% 34.1 – 34.9% 35.3 – 36.1% 36.5 – 37.3% 37.6 – 38.4% 38.8 – 40.8% 41.2 – 42.0% 42.4 – 43.1% 43.5 – 44.3% 44.7 – 45.5% 45.9 – 46.7% 47.1 – 47.8% 48.2 – 49.0% 49.4 – 50.2% 50.6 – 51.4% 51.8 – 52.5%	Snap

<b>25</b> (contd.)	Special/Control (contd.)	Focus tracking off*	141 – 143	0	55.3 – 56.1%	Snap
		Focus tracking near*	144 – 146		56.5 – 57.3%	
		<b>Focus tracking medium*</b>	147 – 149		57.6 – 58.4%	
		Focus tracking far*	150 – 152		58.8 – 59.6%	
		No function	153 – 158		60.0 – 62.0%	
		<b>Framing Control = PI Mode,</b> (position/Index)*	159 – 161		62.4 – 63.1%	
		Framing Control = LR Mode, (left/right)*	162 – 164		63.5 – 64.3%	
		No function	165 – 191		64.7 – 74.9%	
		PWM 2200 Hz **	192 – 194		75.3 – 76.1%	
		<b>PWM 3000 Hz **</b>	195 – 197		76.5 – 77.3%	
		PWM 4800 Hz **	198 – 200		77.6 – 78.4%	
		PWM 9600 Hz **	201 – 203		78.8 – 79.6%	
		No function	204 – 206		80.0 – 80.8%	
		PWM 25 kHz **	207 – 209		81.2 – 82.0%	
		Set fixture to factory defaults**	240 – 242		94.1 – 94.9%	
		No function	243 – 245		95.3 – 96.1%	
Reset pan/tilt *	246 – 248	96.5 – 97.3%				
Reset head*	249 – 251	97.6 – 98.4%				
Reset all*	252 – 255	98.8 – 100%				
<b>26</b>	FX1 selection	No FX	0 – 10	0	0 – 3.9%	Snap
		LED cluster FX 01 Chaser	11 – 14		4.3 – 5.5%	
		LED cluster FX 01 Crossfade	15 – 18		5.9 – 7.1%	
		LED cluster FX 02 Chaser	19 – 22		7.5 – 8.6%	
		LED cluster FX 02 Crossfade	23 – 26		9 – 10.2%	
		LED cluster FX 03 Chaser	27 – 30		10.6 – 11.8%	
		LED cluster FX 03 Crossfade	31 – 34		12.2 – 13.3%	
		LED cluster FX 04 Chaser random	35 – 38		13.7 – 14.9%	
		LED cluster FX 04 Crossfade random	39 – 42		15.3 – 16.5%	
No function	43-255	16.9 – 100%				
<b>27</b>	FX1 adjustment	FX1 speed slow – fast	0 – 255	0	0 – 100%	Fade

\* Move from zero and hold value for 3 seconds to apply

\*\* Move from zero and hold value for 5 seconds to apply

### Notes:

Percentage values are calculated by dividing DMX values by 2.56 and rounding to the nearest 0.1%.

To apply a command on Channel 25 (Special/Control), start at a value of zero, then move to the required value and hold it for the required time (e.g. 3 seconds). If you move to the required value from any other value than zero, the command will not be applied.

To adjust the PWM frequency using the Special/Control channel, start at a value of zero, move to the required value and hold it for at least 5 seconds.

Default settings are written in **bold type**.

## 9. Caring for your product

### **Cleaning**

The buildup of dust, dirt and other airborne particles will reduce the fixture's light output. It will also prevent the fixture from cooling correctly, and this will reduce the fixture's lifetime. The rate of dirt buildup will vary depending on environmental factors such as airborne dust, use of smoke machines, airflow from ventilation systems, etc. The fixture's cooling fans will accelerate buildup, and any smoke particles that are present in the atmosphere will increase the tendency for dirt to clog.

To get the best performance and lifetime from the fixture, inspect it regularly and clean it as soon as you see signs of dirt buildup. Assess the operating environment each time you begin to use the fixture. In dusty or smoky conditions, inspect the fixture after a few hours and check it frequently – the fixture may attract dirt faster than you expect. Draw up a cleaning schedule that will make sure that dirt is removed before it can build up.

Use the following guidelines:

- Disconnect the fixture from power and allow it to cool completely before cleaning.
- Do not use solvents, abrasives or any other aggressive product to clean the fixture.
- Vacuum or use low-pressure compressed air to remove dust and loose particles from surfaces and air vents. Prevent the blades of cooling fans from turning before you aim a vacuum or air jet at the fan, or you may spin the fan too fast and damage it.
- Clean glass components by wiping gently with a soft, clean, lint-free cloth moistened with a weak detergent solution. Put the solution on the cloth, not on the surface to be cleaned. Avoid rubbing glass surfaces. If particles are stuck to the glass, try to lift them off by dabbing them repeatedly with a cotton swab or moistened lint-free cloth.
- Dry the fixture with a soft, clean, lint-free cloth or low-pressure compressed air before reapplying power.

### **Lubrication**

The fixture does not normally need lubrication. If any moving parts show signs of rough movement, consult a GLP service partner.

## 10. Troubleshooting

The checklist below may help you troubleshoot in the unlikely event that a problem occurs while using the product:

<b>Symptom</b>	<b>Possible cause</b>	<b>Suggested action</b>
No response from fixture.	No power to fixture.	Check that power is turned on. Check cables and connections.
	Fuse blown or internal fault.	Contact GLP Service or authorized service partner. Do not remove base or yoke covers. Do not attempt to replace a fuse or carry out any repairs or service that are not described in this User Manual unless you have both authorization from GLP and official GLP service documentation.
Fixture resets correctly but does not respond (or does not respond correctly) to the controller.	Bad data link.	Inspect connections and cables. Correct poor connections. Repair or replace damaged cables.
	Data link not terminated.	Insert DMX termination plug in data output socket of last fixture on data link.
	Incorrect fixture addressing.	Check fixture address and DMX mode settings.
	A fixture is defective and is disturbing data transmission on the link.	Unplug DMX IN and THRU connectors and connect them directly together to bypass one fixture at a time until normal operation is regained. Have defective fixture serviced by an authorized technician.
Error after fixture reset.	Effect requires mechanical adjustment.	Check fixture's software version and error messages for more information. Contact GLP Service or authorized GLP service partner.
Mechanical effect loses position.	Mechanical train requires cleaning, adjustment, or lubrication.	Check fixture's software version and error messages for more information. Contact GLP Service or authorized GLP service partner.
Light output cuts out intermittently.	Fixture too hot.	Allow fixture to cool. Reduce ambient temperature. Ensure free airflow around fixture. Clean fixture if necessary.

## 11. Technical specifications

### Light source

LED type: 350 W white LED engine  
LED lifetime: >20.000 hours (to >70% luminous output)  
CRI (Color Rendering Index): 90+  
CQS (Color Quality Scale): 85+  
TLCI (Television Lighting Consistency Index): 85+  
TM-30 Rf (IES TM-30-15 Fidelity Index): 85+  
TM-30 Rg (IES TM-30-15 Gamut Index): 95+  
CCT: 6000 K

### Optics

Luminous flux: 7300 – 10 300 lumens  
Zoom range, half-peak: 6° - 45°  
Zoom range, one-tenth peak: 12° - 60°  
Zoom range, cutoff (3%): 17° - 68°  
Zoom ratio: 5:1  
Output lens diameter: 185 mm / 7.3 in.

### Effects

Color mixing: CMY, independently variable 0-100% continuous  
Color wheel: 10 x colors (including 3 x CTC and Minus Green as standard) plus open, adjustable via CMY  
CTC continuous: 2500 – 8000 K continuously variable  
Iris: Continuously variable, 14-blade  
Dimmer: 0-100% continuous, electronic 16-bit, choice of two dimming curves  
Shutter/strobe: Instant open and blackout, pulse and strobe effects up to 10 Hz, electronic  
PWM frequency: Variable  
Pre-programmed effects: FX channel with LED engine FX etc.  
Focus: Continuously variable  
Zoom: 6° - 45° half-peak angle, 12° - 60° field angle, automatic focus tracking options  
Framing: 4-blade framing module, full blade overlapping, individual blade control with 0-100% insertion and +/-30° tilt  
Framing module rotation: +/-45°, two control modes

### Movement

Resolution: 8- / 16-bit  
Positional feedback: Yes  
Pan range: 640°  
Tilt range: 262°

## Control

Control systems: DMX, RDM  
Onboard interface: Battery-powered control panel with backlit graphic display  
DMX channels: 27  
16-bit control: Dimming, pan and tilt  
DMX compliance: USITT DMX512-A  
RDM compliance: ANSI/ESTA E1.20  
Transceiver: RS-485  
Receiver: Opto-isolated RS-485  
Wireless DMX: Optional via Lumenradio CRMX PCB plugin  
Art-Net and sACN: Via Ethernet  
Fixture software update: Via DMX link with GLP interface  
Standalone: DMX 'snapshot' recorded via DMX, can auto-start at power on

## Installation

Orientation: Any  
Location: Dry location only, fastened to surface or structure or free-standing on supplied tripod floor stand  
Mounting points: 4 x camlock fastener points, 2 x M10 threaded holes  
Eyelets in fixture base for safety cable attachment  
Minimum distance to illuminated surfaces: 2.0 m (6.6 ft.)  
Minimum distance to combustible materials: 0.2 m (8 in.)

## Connections

AC mains power in: Neutrik powerCON TRUE1  
DMX and RDM data in and out (thru), firmware upload: 5-pin XLR  
Art-Net, sACN: Neutrik etherCON

## Electrical

AC power: 100-240 V, 50/60 Hz  
Internal power supply unit: Auto-ranging electronic switch-mode  
Maximum power consumption at 230 V: 550 W  
Minimum power consumption (all effects static, zero light output): 80 W typical  
Primary fuse: T 5 A, 250 V, 6x32 mm  
EEC (Energy Efficiency Class): B  
EEI (Energy Efficiency Index): 0.58  
Energy consumption (kWh/1 000 h): 461

## Thermal

Cooling: Combined convection and temperature-regulated forced air  
Cooling management: Four fan operation modes  
Thermal protection system  
Maximum surface temperature: 55° C / 131° F  
Maximum ambient temperature: 45° C / 115° F  
Minimum ambient temperature: 5° C / 41° F  
Total heat dissipation (calculated, max. power at 230 V): 1880 BTU/hr.

### **Construction**

Color: Black (standard)

Housing material: Impact-resistant flame-retardant thermoplastic

Ingress protection rating: IP20

### **Included items**

Power cable (depending on region):

- US power cable: 16 A, 14 AWG, UL listed, E304117, SJT, 4.9 ft.

- EU power cable: 16 A, 1.5 mm<sup>2</sup>, H05VV-F, 1.5 m

Detachable tripod floor stand

### **Shipping options**

Single product: Cardboard packing case

Tour packs: 2-fixture flightcase

### **Dimensions and weight**

Depth (max., head horizontal): 510 mm / 20.1 in.

Width (across yoke): 472 mm / 18.6 in.

Height (head vertical): 637 mm / 25.1 in.

Height (head vertical, with tripod): 662 mm / 26.1 in.

Minimum center-to-center distance: 600 mm / 23.6 in.

Weight: 25.5 kg / 56 lb.

## 12. Dimensions

All dimensions are given in millimeters

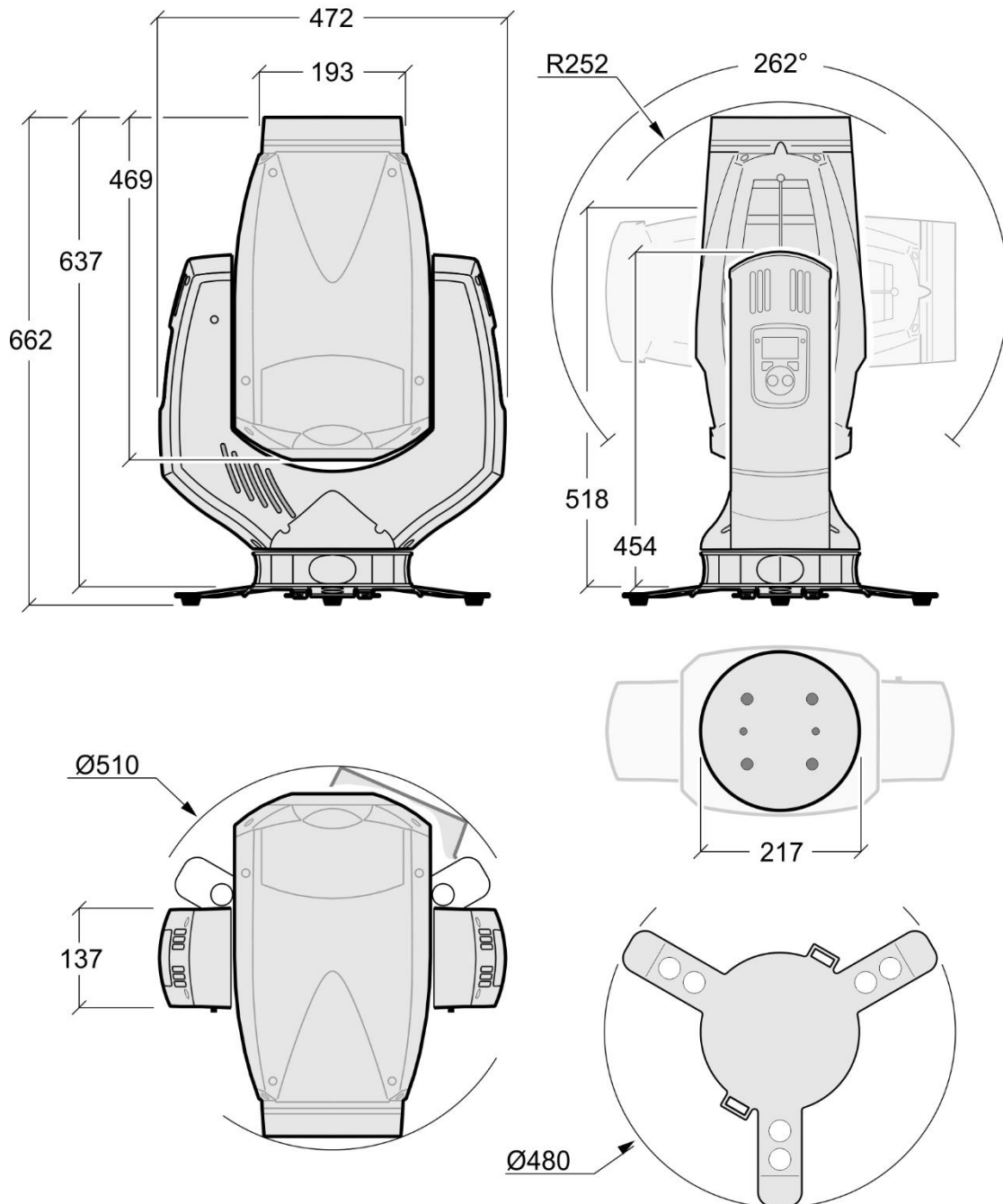



### **Protecting the environment**



GLP products are supplied in compliance with Directive 2012/19/EC of the European Parliament and of the Council of the European Union on WEEE (Waste Electrical and Electronic Equipment), where applicable.

Help preserve the environment. Ensure that this product is recycled at the end of its life. Your supplier can give details of local arrangements for the disposal of GLP products.



This product contains a lithium battery. Ensure that it is disposed of correctly and responsibly by an authorized recycling or waste disposal center at the end of its life. Where applicable, GLP participates in schemes that aim to ensure that local recycling and/or waste disposal centers accept batteries from GLP products.





